



# IMPULSE®•G+ Mini

Quick Reference Guide



© Copyright 2008 Magnetek, Inc.  
Part Number: 144-25086

This guide will assist you in quickly configuring the IMPULSE®•G+ Mini. It will guide you through configuring your drive to handle most applications. The figure below shows the basic wiring for the G+ Mini.

For advanced wiring and programming features please refer to the complete set of IMPULSE•G+ Mini adjustable frequency drive manuals.

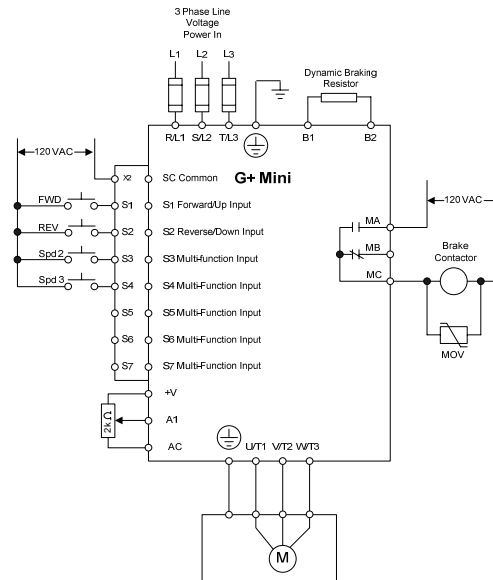

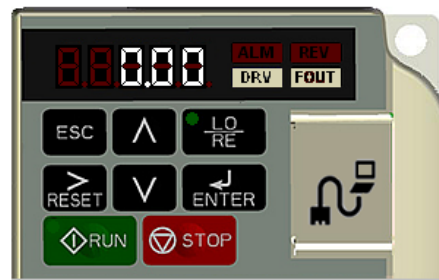

Basic programming of the drive consists of entering motor parameters, choosing a motion, and selecting a speed reference.

After applying power to the drive, the display will show the output frequency of 0.00.





**Navigation Keys:**

The above figure shows the keypad on the G+ Mini. These keys are used for navigation and for changing various settings within the drive.

Use the  and  keys to change the display and/or change the value of a parameter.

Use the  key to move the cursor to the right and to reset the drive after a fault.

Use the  key to view and save any parameters changes or the  to exit without saving changes.

**Setting Motion:**

1. From the output frequency display, press the  key five times until the display shows the parameter menu (PAR).



2. Press . The display will show A01.01.



3. Press  two times to move the blinking digit to the right.



4. Press  until the parameter A01.03 (Motion) appears.

5. Press .



Use the following table to select the desired motion for your application.

A01.03 – Motion	
Data Value	Function
00	Traverse
01	Hoist (Default)

6. Use the , , and  keys to change the value.



7. Press  to save your changes. The display will temporarily show , then A01.03.



**Setting Speed Reference:**

8. Press the  key to navigate to A01.04 (Speed Reference), press .

Use the following table to select the speed reference for your application.



A01.04 – Speed Reference	
Data Value	Function
00	Two-speed Multi-step
01	Three-speed Multi-step (Default)
02	Five-speed Multi-step
03	Two-speed Infinitely Variable
04	Three-speed Infinitely Variable
05	Uni-Polar Analog (0-10 VDC or 4-20mA)

9. Use the , , and  keys to change the value.



10. Press  to save your changes. The display will temporarily show , then A01.04.

### Setting Motor Full Load Amps:



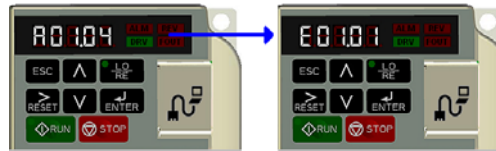



Locate the nameplate on your motor to find the Full Load Amps (FLA), and the motor RPM.

11. Press the  key once to move the cursor to the left most spot.  
Use the  and  keys to navigate to the "E" menu.  
The display should show E01.01.



12. Press the  once to move the blinking digit to the right
13. Press  once to change from E01 to E02. The display now shows E02.01 (Motor FLA). Press  twice.

**NOTE:** If more than one motor is being controlled by the drive, enter in the total of all the motor full load amp ratings. This step is important to provide proper motor overload protection.

14. Use the , , and  keys to enter the FLA from the motor nameplate.
15. Press  to save your changes. The display will temporarily show , then E02.01.
16. Press  four times to return to the frequency reference display.

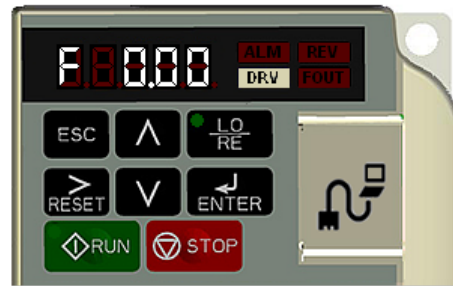

17. Your drive is now ready.

G+ Mini Manuals	
P/N	Manual Name
144-25084	G+ Mini Basic Instruction Manual
144-25085	G+ Mini Advanced Instruction Manual
144-25086	G+ Mini Quick Start Guide

**Parameter Reference Table**

Parameter	Function	Settings
A01.01	Access Level	0001 = Basic (Default) 0002 = Advanced
A01.02	Control Method	00 = V/F (Default) 02 = Open Loop Vector*
A01.03	Motion	00 = Traverse 01 = Hoist (Default) 04 = Braketric®*
A01.04	Speed Reference	00 = Two-speed Multi-step 01 = Three-speed Multi-step 02 = Five-speed Multi-step 03 = Three-speed Infinitely Variable (Default) 04 = Three-speed Infinitely Variable 05 = Uni-Polar (0-10 VDC, 4-20 mA)
B05.01	Accel Time	0.00 to 25.5 seconds
B05.02	Decel Time	0.00 to 25.5 seconds
E01.01	Input Voltage	155 to 255 VAC for 230 V drives 310 to 510 VAC for 460 V drives
E02.01	Motor Rated Current	Depends on inverter capacity

\*Access level must be set to Advanced (A01.01=2) to enable these features. Advanced features are covered in the G+ Mini Advanced Instruction manual (P/N 144-25085).