

TELEMOTIVE SERIES 10K6/9

Magnetek Material Handling

Radio Control System

Instruction Manual



Telemotive

TC10K6/9-0 Rev. D January 2006

Part Number: 21462T

©Copyright 2006 Magnetek Material Handling

This page intentionally left blank.

Table of Contents

1-	Service Information	1
2-	Radio Controlled Crane Safety	3
	1. Warnings, Cautions and Notes	3
	2. Critical Installation Considerations	3
	3. General	4
	4. Persons Authorized To Operate Radio Controlled Cranes	4
	5. Training Checklist For Crane Operators	4
	6. Operating Area	4
	7. Transmitter Unit	5
	8. Operating The Crane	5
	9. Boarding The Crane	6
	10. Crane Maintenance and Repair	6
	11. Using The Crane As A Work Platform	7
	12. Condition Of The Radio Controlled Crane	7
	13. Batteries	8
3-	General System Information	11
	1. General System Information	11
	2. TMS Low Power Signaling	11
	3. System Specifications	11
	4. Transmitter Unit	11
	5. Receiver Unit	11
4-	Installation Information	13
	1. Pre-Installation Considerations	13
	2. Receiver Unit Mounting Location Considerations	13
	3. Antenna Unit Mounting Considerations	13
	4. Line Input Considerations	13
	5. Wiring Considerations	13
	6. Receiver Receiver/Equipment Interface Considerations	14
	7. Receiver Unit Cabinet Mounting	14
	Figure 4-1. Receiver Enclosure Mounting Holes	15
5-	Operation	17
	Figure 5-1. Membrane, Slider and Pendant Transmitters	17
	1. Transmitters Functions	17
	2. Transmitter LED Indicator	18
	3. Operation	18
	4. Battery Replacement	18
6-	Wiring Diagram	19
	1. Wiring Diagrams	19
	2. Installation	19
	3. Alarms and Horns	19
	4. Membrane Transmitter Wiring	19
	5. Single-Speed Pendant Transmitter Wiring	19
	6. Two-Speed Pendant Transmitter Wiring	19
	7. Relay Sequencing	19
	8. Legend	20
	Figure 6-1. Legend	20
	Figure 6-2. 10K6, Single Receiver, Two Motor Interface Single-Speed	20
	Figure 6-3. 10K6, Single Receiver, Two Motor Interface Two-Speed	21
	Figure 6-4. 10K9, Two Receivers, Two-Speed North/South Bridge, Single-Speed East/West Trolley and Hoist	22
	Figure 6-5. 10K9, Two Receivers, Two-Speed North/South Bridge, East/West Trolley and Hoist	23
	Figure 6-6. 10K9, Two Receivers, Two-Speed East/West Bridge, Single-Speed North/South Trolley and Hoist	24
	Figure 6-7. 10K9, Two Receivers, Two-Speed East/West Bridge, North/South Trolley and Hoist	25

Table of Contents (Continued)

	Figure 6-8. 10K6, Single Receiver, Single-Speed Bridge, Trolley and Hoist	26
	Figure 6-9. 10K6, Single Receiver with Single-Speed Pendant, Single-Speed Bridge, Trolley and Hoist	27
7-	Access Code and Receiver Programming	29
	1. Programming Access Codes	29
	2. Changing Transmitter Access Codes	29
	3. Receiver Access Code Setting	30
	4. Latchable Relays	30
	5. Receiver Time-out-timer	30
	6. Transmitter Programming (Other)	30
	7. Multibox Operation	31
8-	Servicing and Transmitter Programming	33
	1. Receiver Servicing	33
	Figure 8-1. Receiver Board Layout	33
	Table 8-1. Receiver Board Diagnostic LED Functions	34
	Figure 8-2. Receiver Scope Wave Forms	36
	2. Membrane Transmitter Servicing and Programming	37
	Figure 8-3. Membrane Transmitter M/C Module E10635	37
	Figure 8-4. Repositioning of Membrane Transmitter Motion Switch Functions	39
	3. Single-Speed Membrane Configurations	40
	Figure 8-5. Membrane Transmitter Single-Speed Configurations	40
	4. Pendant Transmitter Servicing and Programming	41
	Figure 8-6. Pendant Transmitter M/C Module E10636	41
	Figure 8-7. Repositioning of Pendant Transmitter Motion Switch Functions	43
9-	Spare Parts	45

Section 1 - Service Information

U.S. Service Information

For questions regarding service or technical information contact:

**1-866-MAG-SERV
(1-866-624-7378).**

Magnetek Material Handling
N49 W13650 Campbell Drive
Menomonee Falls, WI 53051

Telephone: 800-288-8178

Website: www.magnetekmh.com
e-mail: info@magnetekmh.com

Fax Numbers:

Main: 800-298-3503
Sales: 262-783-3510
Service: 262-783-3508

For Canada Service Information Contact

Berlet Electronics:
Phone: 1-905-564-2710
Fax: 1-905-564-2755

Section 1 - Service Information (Continued)

This page intentionally left blank.

Section 2 – Radio Controlled Safety

2-1. Warnings, Cautions and Notes.

Through out this document **WARNING**, **CAUTION** and **NOTE** statements have been deliberately placed to highlight items critical to the protection of personnel and equipment.

WARNING – A warning highlights an essential operating or maintenance procedure, practice, etc. which if not strictly observed, could result in injury or death of personnel, or long term physical hazards. Warnings are highlighted as shown below:



CAUTION – A caution highlights an essential operating or maintenance procedure, practice, etc. which if not strictly observed, could result in damage to, or destruction of equipment, or loss of functional effectiveness. Cautions are highlighted as shown below:



NOTE – A note highlights an essential operating or maintenance procedure, condition or statement. Notes are shown as below:

NOTE

WARNINGS, CAUTIONS AND NOTES SHOULD NEVER BE DISREGARDED.

The safety rules in this section are not intended to replace any rules or regulations of any applicable local, state, or federal governing organizations. The following information is intended to be used in conjunction with other rules or regulations already in existence. It is important to read all of the safety information contained in this section before installing or operating the Radio Control System.

2-2. Critical Installation Considerations.

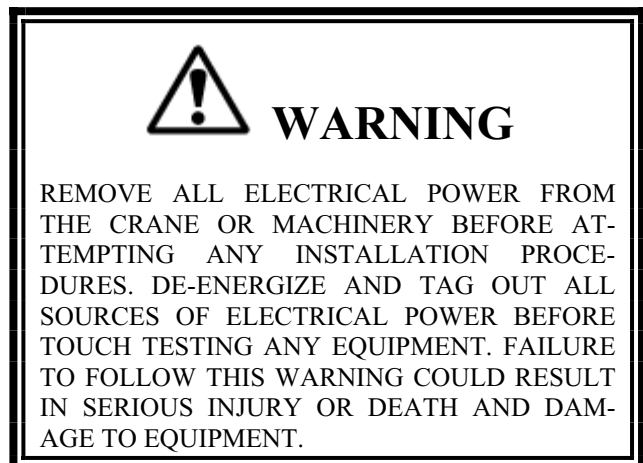
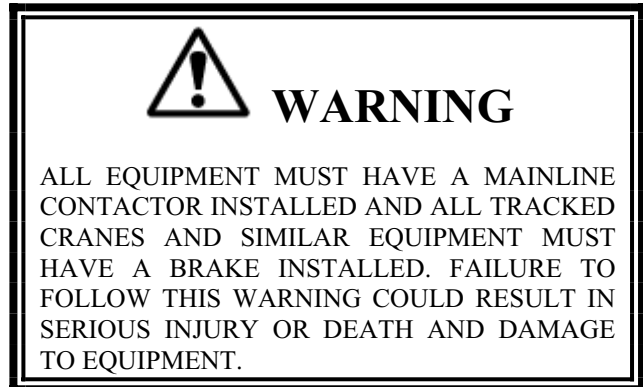

Section 2 – Radio Controlled Safety (Continued)



WARNING

THE DIRECT OUTPUTS OF THIS PRODUCT ARE NOT DESIGNED TO INTERFACE DIRECTLY TO TWO STATE SAFETY CRITICAL MAINTAINED FUNCTIONS, I.E., MAGNETS, VACUUM LIFTS, PUMPS, EMERGENCY EQUIPMENT, ETC. A MECHANICALLY LOCKING INTERMEDIATE RELAY SYSTEM WITH SEPARATE POWER CONSIDERATIONS MUST BE PROVIDED. FAILURE TO FOLLOW THIS WARNING COULD RESULT IN SERIOUS INJURY OR DEATH AND DAMAGE TO EQUIPMENT.

2-3. General.

Radio controlled overhead cranes and other material handling equipment operate in several directions. They are large, bulky pieces of equipment that handle heavy loads efficiently at high speeds. Quite frequently, the equipment is operated in areas where people are working on the floor below. The crane operator must exercise extreme caution at all times. Workers must constantly be alert to avoid accidents. The following rules have been included to indicate how your careful and thoughtful actions may prevent injuries, damage to equipment, or even save a life. If radio controlled material-handling equipment is operated from the cab, special care must be taken to secure the transmitter. Refer to section titled [Section 2-9. Boarding The Crane](#) for specific safety rules.

2-4. Persons Authorized To Operate Radio Controlled Cranes.

Only properly trained persons designated by management should be permitted to operate radio-controlled cranes.

Radio controlled cranes should not be operated by any person who cannot read or understand signs, notices and operating instructions that pertain to the crane.

Radio controlled cranes should not be operated by any person with insufficient eyesight or hearing or by any person who may be suffering from a disorder or illness or is taking any medication that may cause loss of crane control.

2-5. Training Checklist For Crane Operators.

Anyone being trained to operate a radio-controlled crane should possess as a minimum the following knowledge and skills before operating the crane:

The operator should have knowledge of hazards peculiar to crane operation.

The operator should have knowledge of the safety rules for radio-controlled cranes.

The operator should have the ability to judge distance or moving objects.

The operator should have knowledge of the radio transmitter.

The operator should know the limit switch test procedure.

The operator should know, where authorized, instructions for plugging motions.

The operator should have knowledge of the use of crane warning lights and alarms.

The operator should have knowledge of observing crane signal lights.

The operator should be trained to avoid striking any obstructions.

The operator should have knowledge of the proper clearance of lifts or hooks before moving bridge or trolley.

The operator should have knowledge of the proper storage space for radio control box when not in use.

The operator should be trained in transferring radio control box to another person.

The operator should be trained how and when to report unsafe or unusual operating conditions.

The operator should be trained how to exhibit caution in approaching bridge or trolley bumpers.

The operator should know equipment capacity.

The operator should be trained in making lifts below floor level.

The operator should be trained in making side pulls.

The operator should know how to keep himself and other people clear of lifts and to avoid "pinch" points.

Section 2 – Radio Controlled Safety (Continued)

The operator should know cable and hook inspection procedures.

The operator should know procedures for testing hoist, trolley, and bridge brakes.

2-6. Operating Area.

Aisles between equipment, stock, etc., should be free of obstructions so the crane operator can move freely. These aisles should be a minimum of 3 feet (1 meter) wide, or meet local regulations.

Crane operators should always position themselves for the best view of the crane they are controlling. The crane should never be operated blindly. The operator should stay as close to the crane load as possible. Operators should never position themselves in a "pinch" point.

2-7. Transmitter Unit.

Transmitter switches should never be mechanically blocked ON or OFF for any crane motion. When not in use turn the transmitter OFF. A secure storage space should be provided for the transmitter unit and the transmitter unit should always be placed there when not in use. This precaution will prevent unauthorized people from operating the crane.

Spare transmitters should be stored in a secure storage space and only removed from the storage space after the current transmitter in use has been turned OFF, taken out of the service area and secured.

2-8. Operating The Crane.

2-8.1. Pre-operation Test.

At the start of each work shift, or when a new operator takes control of the crane, operators shall do as a minimum the following steps before making lifts with any crane or hoist:

Test the upper-limit switch. Slowly raise the unloaded hook block until the limit switch trips. When checking limit switches the hoist should be centered over an area free of personnel and equipment.

Visually inspect the hook, load lines, trolley, and bridge as much as possible from the operator's station; in most instances, this will be the floor of the building.

The bridge and trolley brakes should be tested. On transmitter units equipped with two or more speeds, use the "lowest" speed when testing braking devices.

When lifting maximum loads, the crane operator should test the hoist brakes by raising the load a few inches from the floor. If the brakes do not hold, the load should immediately be lowered to the floor.

If provided, test the lower-limit switch.

Test all warning devices.

Test all direction and speed controls for both bridge and trolley travel.

Test all bridge and trolley limit switches, where provided, if operation will bring the equipment in close proximity to the limit switches.

Test the transmitter emergency stop.

Test the hoist brake to verify there is no drift without a load.

If any crane or hoist that fails any of the above tests notify the supervisor and lock out and tag for repair.

2-8.2. General rules for operation.

Consult the crane manufacturer, local and governmental regulations for complete rules of operation. In general the following rules apply to remotely controlled cranes:

The limit switches should never be used as a regular stopping device. They are intended to be protective devices.

Do not make lifts in excess of the equipment rated capacity.

The bridge and trolley should be centered directly over the load when the load is raised to prevent swinging when making lifts.

A crane designed for this purpose and only with supervisor permission should make side pulls. When a lift is being made, the crane operator should not be positioned in the line of travel. The crane or hoist should be operated from a position either to the side or opposite from the direction of travel.

When raising or lowering a load, proceed slowly and make certain the load is under control. Tag lines should be used for handling unusual lengths or bulky loads. Remove slack from chains or slings gradually.

Section 2 – Radio Controlled Safety (Continued)

Make certain all personnel are clear before making a lift.

The crane operator should keep all body parts away from the lift and should never be positioned under the lift.

Do not make a lift or move a load if anyone is in a location where they could be struck by the crane or the load.

If the crane operator is being helped, the crane should not be moved until the helper signals they are clear of the crane and its load.

When a load is hanging from the crane hook and the crane is being moved, the crane operator should sound all warning devices frequently.

Loads should not be carried over workers heads. If a worker is in the path of crane travel, the crane operator should stop the crane and clear the area before proceeding.

Runway stops or other cranes should never be bumped into.

When moving the crane, the crane operator should be sure that the hook block and attachments or cables would not catch on nearby equipment. Slings, chains, or cables should never be dragged along the floor.

Unless required for operator safety, gloves should not be worn when operating the transmitter unit.

All loose materials or parts should be removed from the load before starting the lift.

The crane operator should always hoist lifts high enough to clear all equipment and workers.

The crane operator should never permit anyone to ride on the load or hook except when authorized by the supervisor.

When another crane on the same runway is stationary with a load hanging, the crane operator should maintain a safe distance between the stationary crane and the one under their control.

Never leave suspended loads unattended. In an emergency, if the crane is inoperative and a load suspended, notify the supervisor immediately, barricade and post signs on the floor beneath crane and load.

If power to the crane is removed, the crane operator should turn the transmitter unit OFF and keep it OFF until power is restored.

If the crane fails to respond properly, the crane operator should stop operation, turn the transmitter unit OFF and immediately report the condition to their supervisor.

Outdoor cranes, which are subject to movement by wind, should be securely anchored when left unattended. If the crane is equipped with bridge brakes, the parking brake should be set immediately.

2-9. Boarding The Crane.

The crane should not be boarded without permission of the supervisor.

The crane operator should turn off the transmitter and take it with them when boarding the crane.

If more than one person is boarding the crane, one person should be made responsible for ensuring all personnel are off the crane before the system is returned to operation.

2-10. Crane Maintenance and Repair.

Qualified personnel must maintain a regularly, i.e., such as monthly, scheduled crane inspection. During this crane inspection, the functionality and safety of the crane remote control must also be tested. The inspection shall include, but be not limited to items listed in [Section 2-12. Condition Of The Radio Controlled Crane](#). Consult crane manufacturer, local and governmental regulations for recommended inspection intervals and proper inspection procedures. Problems noted during this inspection must be repaired before using the crane or the remote control.

Minor repairs include routine maintenance and repairs such as greasing, cleaning and control troubleshooting. All other repairs should be considered major. If the repair crew consists of more than one person, one person should be designated as the repair crew leader with the following responsibilities. If the repair crew consists of only one person, that person has the following responsibilities:

For minor repairs, warning signs should be placed on the floor beneath the crane or suspended from the crane. For major repairs, the floor area below the crane should be roped off.

Section 2 – Radio Controlled Safety (Continued)

When major repairs are to take place, all persons operating other cranes on the same or adjacent runways, if any, must be notified prior to starting repairs. Notification should include the nature of the repair, safeguards provided, and movement limitations while repairs are in progress.

When practical, radio controlled cranes which cannot be moved during repairs must be protected against being bumped by other cranes on the runway. Bumpers should be installed on the exposed side or sides of the crane under repair. They should be placed as far away as possible. The location of these bumpers should be indicated by red lights placed so that they are clearly visible to other crane operators traveling on the same runway. When it is not possible to use bumpers, red lights must be placed so they are clearly visible to other crane operators traveling on the same runway to indicate the restricted travel zone. All crane operators on the same runway must be informed of the repair effort and thoroughly instructed as to what their operations are limited to and informed that they will be notified when repairs are completed.

If any hazard involving the repairmen exists when there is a runway adjacent to the crane under repair, the adjacent runway should be blocked off as described above. When it is necessary to continue crane operation on the adjacent runways warning lights must be installed and be visible to operators of cranes on those runways. All cranes should come to a complete stop prior to entering the restricted area and should proceed through this area only after receiving permission from a signal person designated for this purpose. Access of persons to and from the crane being repaired should be under control of the repair crew leader.

When boarding the crane, the transmitter should be turned OFF and the transmitter should remain with the repair crew leader. The leader should board the crane first, open and lock out the main switch, and then signal the other members of the crew it is safe to board the crane.

If work on the crane is to be done in areas not protected by standard handrails, the repair crew should wear approved safety belts.

All tools and equipment should be moved onto the crane by the use of hand lines. The tools and equipment should be adequately secured to the hand lines.

If it is necessary to have the crane control circuits energized, all power circuits for crane movement must be opened prior to energizing the control circuits.

All personnel and tools should be moved to a safe spot before moving the crane during repairs.

Headroom is at a minimum in some crane cabs and on some crane walkways. Caution should be exercised when boarding or working on cranes. Hard hats should be worn whenever possible.

When repairs are finished, all personnel, tools and repair equipment should be removed before energizing the crane circuits.

2-11. Using The Crane As A Work Platform.

When the crane is to be used as a stationary work platform, follow all rules provided in [Section 2-10. Crane Maintenance and Repair](#). When it is necessary for the crane to be moved from time to time, the crane operator should board the crane with the transmitter unit. The crane operator should ensure all personnel working on the crane are in a secure position before moving the crane to the next workstation. It should also be the crane operator's responsibility to ensure the main switch is open and locked down before work is resumed.

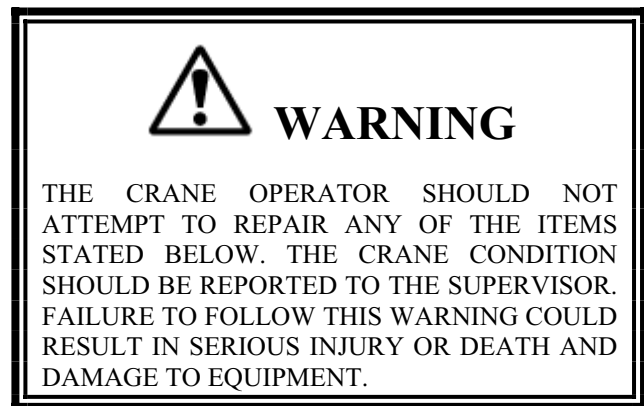

2-12. Condition Of The Radio Controlled Crane.

If the crane fails to respond properly, the crane operator(s) should notify their supervisor. When serious conditions are noticed (conditions that make the crane unsafe to operate), the crane should be shut down immediately and the supervisor notified. The following is a list of some of the items that should be included in the report. (See the crane manufacturer for specifics and possible additional items):

Section 2 – Radio Controlled Safety (Continued)

Condition of hoisting cable and hook block (broken strands, clipped sheave wheels, etc.).

Condition of brakes (hoist, trolley, and bridge). (no bluing, rivets on shoes showing, glazing, etc.).

Condition of trolley and rail stops.

Condition of bridge structure.

Condition of festoon system.

Broken welds in any part of the crane structure.

Proper fluid levels and lubrication.

Condition of bridge and trolley stops.

Carbon dust or signs burning on the covers of motors.

Indication of fluid, oil or grease leaks.

Condition of rail sweeps.

Walkways required handrails and ladders are in place, sturdy and not loose.

Protective guards are in place for all moving parts.

Alignment of bridge (screeching or squealing wheels indicate bridge is out of line).

Broken, cracked, or chipped rails on trolley or runway.

Condition of limit switches.

Condition of electrical and mechanical control (electrical or mechanical defects which cause faulty operation such as un-commanded stopping or starting of any crane motions, warning devices, lights, or auxiliary functions).

Condition of gears (grinding or squealing may indicate foreign materials in gear teeth or a lack of lubrication).

All controls especially E-STOPS are in place and in working order.

Frequent relay tripping of power circuits.

Mechanical parts loosened by vibration (loose rivets, covers, bolts, etc.).

Uneven riding (worn or damaged wheels).

Condition of collector shoes or bars.

Condition of warning or signal lights and horns. (burned out or broken).

2-13. Batteries



WARNING

KNOW AND FOLLOW PROPER BATTERY HANDLING, CHARGING AND DISPOSAL PROCEDURES. IMPROPER BATTERY PROCEDURES CAN CAUSE BATTERIES TO EXPLODE OR DO OTHER SERIOUS DAMAGE. FAILURE TO FOLLOW THIS WARNING COULD RESULT IN SERIOUS INJURY OR DEATH AND DAMAGE TO EQUIPMENT.

2-13.1. Battery Handling.

Use only batteries approved by Telemotive for the specific product.

Do not dispose of a battery pack in fire; it may explode.

Do not attempt to open the battery pack.

Do not short circuit battery.

For intrinsically safe environments only use specified Telemotive intrinsically safe batteries.

Keep the battery pack environment cool during charging operation and storage, (i.e., not in direct sunlight or close to a heating source).

Do not attempt to use a battery that is leaking, swollen or corroded.

2-13.2. Battery Charging.

Please familiarize all users with the instructions of the charger before attempting to use.

Use only Telemotive approved chargers for the appropriate battery pack.

Do not attempt to charge non-rechargeable battery packs.

Avoid charging the battery pack for more than 24 hours.

Do not charge batteries in a hazardous environment.

Section 2 – Radio Controlled Safety (Continued)

Do not short charger.

Do not attempt to charge a damaged battery.

Charger units are not intended for outdoor use. Use only indoors.

2-13.3. Battery Disposal.

Before disposing of batteries consult local and governmental regulatory requirements for proper disposal procedures.

Section 2 – Radio Controlled Safety (Continued)

This page intentionally left blank.

Section 3 – General System Information

3-1. General System Information.

The Telemotive Radio Control System (system) provides remote control of overhead cranes using radio signals. The system consists of a hand held portable battery operated transmitter unit and a fixed station receiver unit.

A unique 16-bit code (Access Code) for each system is preset in every transmitter and receiver. The receiver considers any received signal, which does not match the receiver access code setting, invalid. The Access Code is made up of 16-bits (65,000 combinations) and no two similar codes are assigned to any two Telemotive systems.

Up to four systems may be used with the same frequency in a 600-foot area (220 meters). Each transmitter operating on the same frequency may be operated in close proximity, not less than six feet (1.9 meters), to each other.

3-2. TMS Low Power Signaling.

TMS (Time Multiplexed Signaling) is a Telemotive propriety high-speed packet data system. The system software is structured to minimize "on the air" transmission time of any transmitter. This allows for multiple transmitters to share a common frequency. The TMS system is designed so that a transmitter will send a signal for a predetermined ON time, and then will turn OFF. The length of transmitter ON time is referred to as data burst or packet. The packet length is a function of the quantity of data to be sent, and the data rate (baud). Once the packet is sent, the transmitter will turn OFF. This allows for other transmitters to time-share the same frequency when a transmitter has turned OFF. The TMS system software determines the OFF period and repetition rate of the ON period. Since each system has its own access code, up to 4 transmitters can share and have equal access to the same frequency. TMS also allows for reduced battery consumption and extended battery life.

These systems have low power pulsed signaling, FCC certified under Part 15 Telecommunications Code of Regulations, no license is required. The transmitter unit is frequency modulated, low power and is certified under the appropriate regulations. A license is not required for the transmitter or operator.

3-3. System Specifications.

Channel Designations: (The channels listed here are for reference purposes and are not an indication of

production stock. Some channels may take extended delivery contact Telemotive for availability).

AK01 - 439.8 MHz	AK06 - 438.8 MHz
AK02 - 439.6 MHz	AK07 - 438.6 MHz
AK03 - 439.4 MHz	AK08 - 438.4 MHz
AK04 - 439.2 MHz	AK09 - 438.2 MHz
AK05 - 439.0 MHz	AK10 - 438.0 MHz

AK11 - 437.8 MHz	AK16 - 436.8 MHz
AK12 - 437.6 MHz	AK17 - 436.6 MHz
AK13 - 437.4 MHz	AK18 - 436.4 MHz
AK14 - 437.2 MHz	AK19 - 436.2 MHz
AK15 - 437.0 MHz	AK20 - 436.0 MHz

Operating Temperature: -22° F to +158° F (-30° C to +70° C) ambient.

Humidity: up to 95 % (non-condensing).

Typical Operating Range: 200 feet (70 meters).

Rating of output relays (including Master Relay): 16 Amp 277 VAC/24 VDC, 1 HP 240 VAC.

3-4. Transmitter Unit.

The transmitter is battery operated has an ON and OFF switch, E-STOP, motor controls and auxiliary controls used for such items as warning indicators.

An LED mounted on the front panel provides battery voltage, ON/OFF indication and data transmission status.

A power down feature allows the transmitter and the receiver unit to turn OFF if no keys are pressed for approximately 15 minutes. The transmitter unit must again be turned ON. The unit uses pulsed operation for extremely long battery life. A configuration of the system is available without automatic timeout.

Housings are designed of high impact, chemical resistant, materials. The antenna for the unit is internal. A strap or belt is provided for carrying the transmitter.

3-5. Receiver Unit.

The receiver unit consists of an RF receiver module, built in antenna with filter, integral power supply, microprocessor controlled output motor control and auxiliary function relays and mainline contactor relay. The receiver unit contains circuitry that matches the frequency and access code of the transmitter.

Section 3 – General System Information (Continued)

The receiver unit is completely contained in a cabinet that is weather and dirt resistant. The receiver unit is turned ON or OFF by direct command of the transmitter. The commands sent by the transmitter control the motor and auxiliary relays.

A power down feature allows the receiver unit to turn OFF if no commands are received for approximately 15 minutes. The transmitter unit must again be turned ON to reactivate the receiver. When the receiver is turned OFF the mainline contactor is opened. A configuration of the transmitter unit is available without automatic timeout.

Section 4 – Installation Information

4-1. Pre-Installation Considerations.

To ensure reliable and safe operation of the system, the following items in Sections 4-1. through 4-7. must be considered before installing the receiver unit per [Section 4-8. EZ Setup](#).

If the receiver is mounted outdoors or in a corrosive environment, the receiver unit cabinet must be housed in a protective enclosure.

The receiver unit should not be subjected to moisture.



WARNING

THE RECEIVER UNIT OR RELAYS ARE NOT RATED AS EXPLOSION PROOF. THE RECEIVER UNIT MUST NOT BE INSTALLED IN EXPLOSIVE ENVIRONMENTS UNLESS APPROPRIATE SECONDARY ENCLOSURE MEASURES ARE TAKEN. FAILURE TO FOLLOW THIS WARNING COULD RESULT IN SERIOUS INJURY OR DEATH AND DAMAGE TO EQUIPMENT.



WARNING

NO MORE THAN FOUR TELEMOTIVE UNITS USING TMS SIGNALING ON THE SAME FREQUENCY SHOULD BE MOUNTED WITHIN 600 FEET (220 METERS) OF EACH OTHER. FAILURE TO FOLLOW THIS WARNING COULD RESULT IN SERIOUS INJURY OR DEATH AND DAMAGE TO EQUIPMENT.

4-2. Receiver Unit Mounting Location Considerations.

Ensure the mounting location is as far as possible from exposed trolley wires and sources of electromagnetic or radiated noise

The receiver unit requires a mounting area approximately 9" (17 mm) wide by 13" (30 mm) high. A depth of at least 10" (19 mm) must be provided to allow the cabinet door to open.

The mounting surface must be smooth and continuous. Mounting the cabinet on uneven surfaces could cause warpage or stress internal components.

The receiver unit may be mounted in any position. Greatest radio control range is obtained when the receiver unit is mounted with the antenna pointed straight up.

If possible, avoid installing receiver unit to a surface where high vibration or shock is present. If this cannot be avoided, use appropriate shock mounts.

4-3. Antenna Mounting Considerations.

The antenna is mounted by placing it in the antenna socket. If mounting the antenna directly in the antenna socket is not possible, the antenna may be mounted remotely using an optional cable, antenna and antenna-mounting bracket. See [Section 9. Spare Parts](#) for part numbers. Contact Telemotive for optional antenna information. In either type of installation, the following must be considered:

An unobstructed line of sight path should be provided between the receiver unit and the area where the transmitter unit is normally used.

The antenna must be 6 feet (1.9 meters) minimum from equipment power lines.

The antenna must not come in contact with equipment chassis, power lines, or structural components during operation.

4-4. Line Input Considerations.



WARNING

THE UNIT MUST BE WIRED TO THE CORRECT VOLTAGE, AND BE CONNECTED TO THE CORRECT TERMINAL AS REQUIRED BY THE ACTUAL LINE VOLTAGE, FAILURE FOLLOW THIS WARNING COULD RESULT IN SERIOUS INJURY OR DEATH AND DAMAGE TO EQUIPMENT.

The receiver unit has direct connect provisions for operation from 120 or 240 VAC (nominal), 50-60 Hz power.

For applications where line voltage deviation exceeds 20% of nominal values, if line voltage is not between

Section 4 – Installation Information (Continued)

95-130 VAC or 190-260 VAC or if 440 VAC power is used, a step up or step down transformer must be used.

NOTE

THE RECEIVER UNIT SHOULD NOT BE CONNECTED TO LINES CONTAINING EXCESSIVE POWER UP TRANSIENTS OR CONTINUOUS COMMUTATOR NOISE. A LINE CONDITIONER MAY BE NECESSARY IN SOME INSTALLATIONS.

4-5. Wiring Considerations.

1. Read this manual before installation.
2. Please observe appropriate local and National Electrical Codes when wiring electrical devices.
3. Do not connect or disconnect wiring, or perform circuit checks while the power is turned on.
4. The motor wiring should be in a separate metal conduit from the power wiring, which should also be in metal conduit.
5. Low voltage wires shall be wired with proper low voltage class wiring procedures.
6. Control wiring as well as antenna wiring shall be in separate conduit and shall be kept as short as possible.
7. All terminals shall be tightened to specified terminal torque 4.4 IN-LBS (.5 N·m), unless otherwise specified.
8. Remove excess metal screws, metal filings and wire clippings from inside of unit.
9. Inspect to make sure no exposed wire has contact with any other wiring or terminals.
10. Suppressors are strongly recommended on all contactors.

4-6. Receiver/Equipment Interface Considerations.

All output relay contacts are rated at 16 amps 250 VAC, however the system rating for the contacts is 5A. Connection to equipment or contactors with higher voltage or current requirements will require intermediate relays.

All relay outputs are normally open, momentary contact. Since a relay closure is only active while the transmitter unit key is pressed and held, devices such as lights or lifting magnet must use a mechanical auxiliary latching relay.

NOTE

FOR INFORMATION ON INTERFACING WITH SYSTEMS WITH HIGH IMPEDANCE INPUTS SEE [SECTION 6-8. CONNECTING OUTPUTS TO DRIVES](#) OR CONTACT TELEMOTIVE.

4-7. Receiver Unit Cabinet Mounting.

Prepare a template or scribe marks directly on surface to which it will be mounted. Drill four 9/32" holes. See [Figure 4-1. Receiver Enclosure Mounting Holes](#).

Recommended mounting hardware is four - 1/4-20 hex machine screws of appropriate length, four 1/4-20 x 7/16 "keps" or elastic stop nuts.

Flat washers should be used in front of nuts when receiver unit is mounted to a non-structural surface.

Mount receiver unit cabinet securely to mounting surface.

Remember to install the antenna after mounting the receiver cabinet.

4-8. EZ Setup.

1. Refer to [Section 6. Wiring](#) and select the crane configuration that matches your application.
2. Refer to the Receiver Configuration Switch programming in [Section 6. Wiring](#) for the selected configuration and set receiver(s) switch SW3 appropriately. See [Figure 8-1. Receiver Layout](#) for SW3 location.
3. Normally the unit is pre-programmed at the factory and only receiver configuration programming is necessary. If it is necessary to latch the auxiliaries, see [Section 7-4. Latchable Auxiliaries](#).
4. DO NOT CHANGE SWITCH SW1 OR SW2. These switches program the access code and should be factory preset.
5. NORMALLY YOU WILL NOT NEED TO CHANGE TRANSMITTER SWITCH SETTINGS. Change the transmitter settings only to change switch positioning, See [Section 8. Servicing and Transmitter Programming](#).

Section 4 – Installation Information (Continued)

6. Make sure fully charged batteries are placed in the transmitter. See [Section 5-4. Battery Replacement](#) for battery servicing information.
 7. Mount receiver cabinet(s) securely to mounting surface per [Section 4-7. Receiver Unit Cabinet Mounting](#).
 8. Install antenna(s) per [Section 4-3. Antenna Mounting Considerations](#).
 9. Connect power leads to appropriate connections on lower left receiver power supply board connector J7, see [Figure 8-1. Receiver Layout](#). (All connectors can be unplugged from board for ease in wiring). Use appropriate connections to power supply board for 120 VAC or 240 VAC.
 10. Using the diagram selected in step 1, wire the control wiring per [Section 4-5. Wiring Considerations](#) to the proper connections on J4 and J5 control wiring connections, see [Figure 8-1. Receiver Layout](#). If there are any questions as to proper wiring procedures contact Telemotive.
 11. Wiring of the 10K6/9 system should now be complete.
 12. Disable power to the Crane Main Control Contactor and all crane control outputs. Enable power to the receiver power supply(s). Green LED's DS11, DS12, DS14, and DS16 should be ON.
 13. Turn ON transmitter, the transmitter red LED should be flashing and the receiver's red LED DS1 should turn ON (MR relay). Using transmitter, check out all functions with the crane disabled, noting the lighting of the appropriate control relay's red LED indicator light (DS2 through DS7) with a transmitter function engaged for the configuration wiring selected in [Section 6. Wiring](#). See [Section 5. Operation](#) and [Table 8-1. Receiver Diagnostic LED Functions](#) for help in determining proper operation.
- AND RECEIVER. [SEE SECTION 7-1. PROGRAMMING ACCESS CODES](#).
14. If the check is successful, enable power to the crane and control outputs. Check all functions and directions by jogging each motion and function. (Jog each motion and function first, in case there is a problem in wiring). If jogging the commands is successful, then attempt full operation of the crane. If all tests successful, installation should now be complete. See [Section 2-8.1. Pre-Operational Test](#).
 15. Before turning controls over to operator (s) make sure all personnel are properly trained. See [Section 2-5. Training Checklist For Crane Operators](#).

NOTE

IF DS1 ON THE RECEIVER DOES NOT COME ON WHEN TURNING ON THE TRANSMITTER, CHECK DS9. IF DS9 THE RED LED ON THE RECEIVER, FLASHES WHEN THE TRANSMITTER IS TURNED ON OR WHILE A FUNCTION BUTTON IS HELD DOWN WHEN THE TRANSMITTER IS ON, THEN THE ACCESS CODES DO NOT MATCH BETWEEN THE TRANSMITTER

Section 4 – Installation Information (Continued)

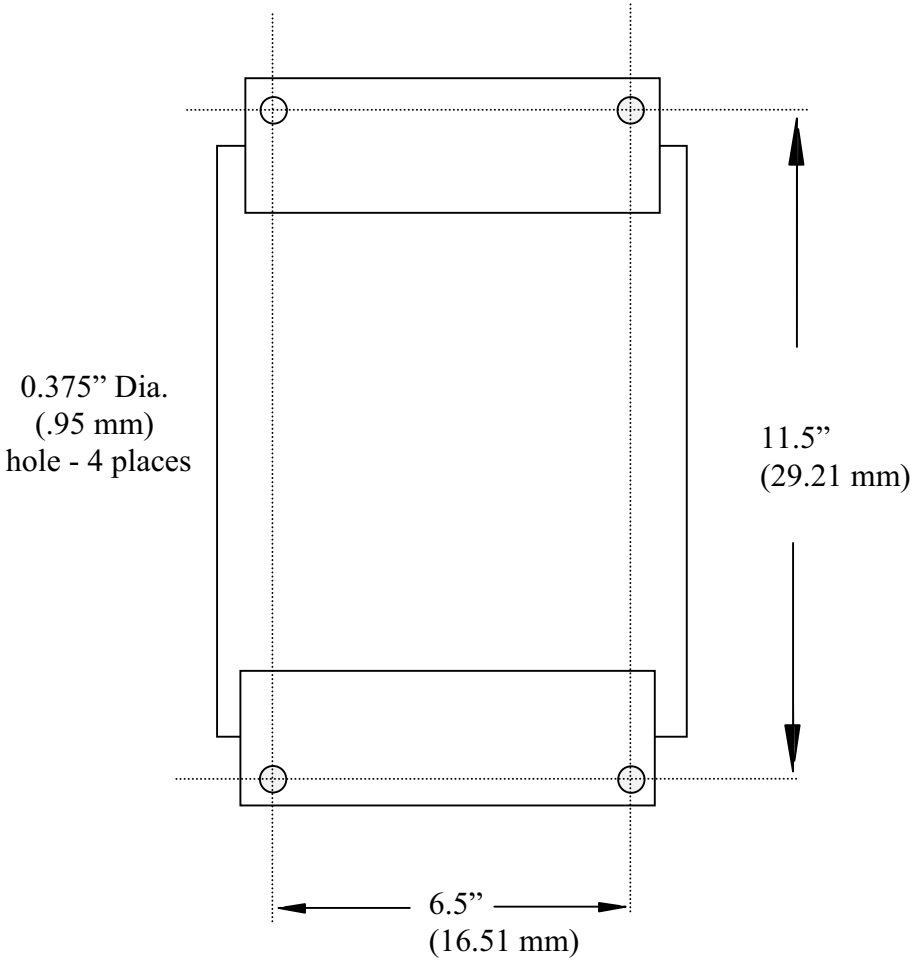

Drawing not to scale.

Figure 4-1. Receiver Enclosure Mounting Holes.

Section 5 – Operation

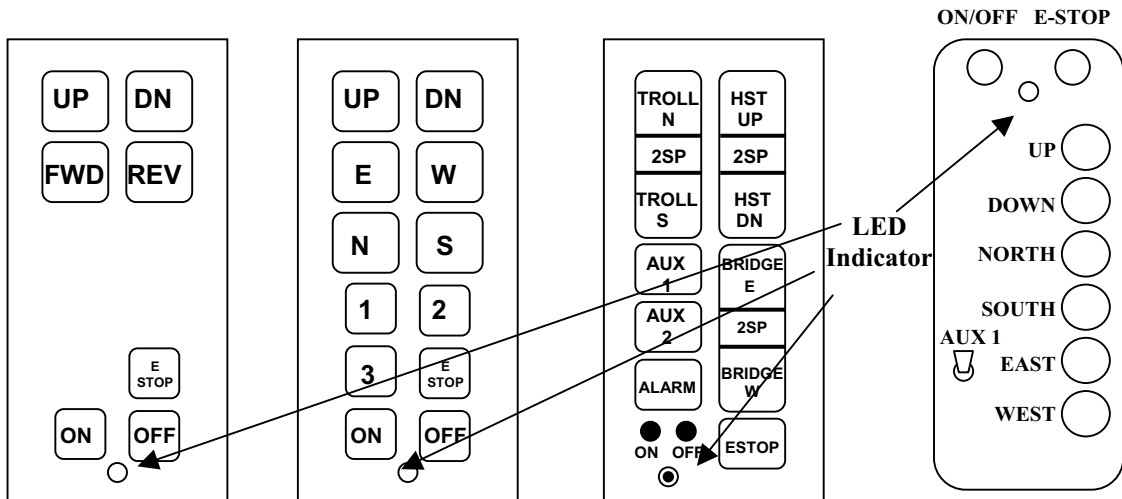

Figure 5-1. Membrane, Slider and Pendant Transmitters.

5-1. Transmitter Functions.

ON – (ON/OFF) Turns the transmitter ON and then sends the ON command to the receiver. (On Slider ON and OFF button is activated by the lanyard key. On the Pendant Transmitter ON and OFF is the same button. On the Pendant the ON/OFF button turns the unit ON.

OFF – (ON/OFF) Sends the OFF command to the receiver and then turns the transmitter OFF. On the Pendant the ON/OFF button turns the unit OFF.

E-STOP (EMS) – Stops all equipment movement and disables all functions. Reset the system for normal operation by turning the transmitter “OFF” then “ON”. Use for emergencies only. (NOT FOR NORMAL SHUT DOWN).

UP (HST UP) – Selects hoist movement in the UP direction speed one (first switch position) or speed two (second switch position). For the Slider the HST UP is pressed and the finger is slid to the center (2SP) for 2nd speed. The first direction is maintained while the second speed key is held.

DN (HST DN and DOWN) – Selects hoist movement in the DOWN direction speed one (first switch position) or speed two (second switch position). For the Slider the HST DN is pressed and the finger is slid to the center (2SP) for 2nd speed. The first direction is maintained while the second speed key is held.

E (FWD, BRIDGE E and EAST) – Selects the appropriate direction of the bridge or trolley (depending how unit is wired at installation) speed one (first switch position) or speed two (second switch position). For the Slider the BRIDGE E is pressed and the finger is slid to the center (2SP). The first direction is maintained while the second speed key is held for 2nd speed.

W (REV, BRIDGE W and WEST) – Selects the appropriate direction of the bridge or trolley (depending how unit is wired at installation) speed one (first switch position) or speed two (second switch position). For the Slider the BRIDGE W is pressed and the finger is slid to the center (2SP) for 2nd speed. The first direction is maintained while the second speed key is held.

N (TROLL N and NORTH) – Selects the appropriate direction of the bridge or trolley (depending how unit is wired at installation) speed one (first switch position) or speed two (second switch position). For the Slider the TROLL N is pressed and the finger is slid to the center (2SP) for 2nd speed. The first direction is maintained while the second speed key is held.

S (TROLL S and SOUTH) – Selects the appropriate direction of the bridge or trolley (depending how unit is wired at installation) speed one (first switch position) or speed two (second switch position). For the Slider the TROLL S is pressed and the finger is slid to the center (2SP) for 2nd speed. The first direction is maintained while the second speed key is held.

Section 5 – Operation (Continued)

1, 2 and 3 (AUX 1, AUX 2, and AUX 3) – Selects the Auxiliary relay(s), which may be used for a warning device as a horn or other function.

5-2. Transmitter LED Indicator.

When the transmitter is ON the red LED flashes slowly. When the unit transmits, the red LED flashes rapidly.

If there is no LED indicator at all after turning ON the transmitter or while operating crane with the transmitter, replace the batteries, they are weak. See [Section 5-4. Battery Replacement](#) on this page for battery replacement.

5-3. Operation.

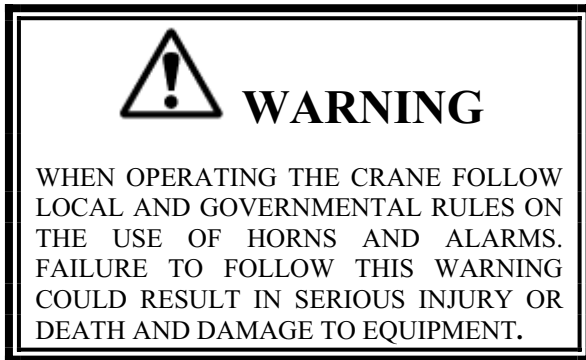
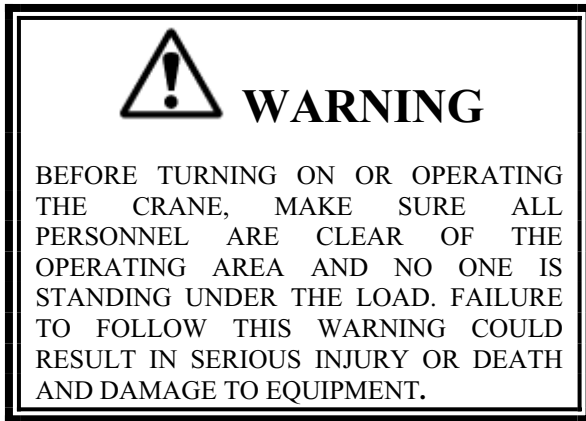

Make sure that all personnel are clear of the crane movement and no one is under the crane or load.

Turn unit ON by pressing the ON (ON/OFF) button. The red LED should flash rapidly for a few seconds indicating the ON command is being sent to the receiver. After the receiver is turned ON the red LED should flash slowly

indicating the transmitter is now ready to send commands.

Perform whatever safety checks are required. See [Section 2. Radio Controlled Safety](#). Operate any horns or alarms as required by local and governmental regulations.

To operate the crane, press and hold the desired function button to maintain operation. Press the directional buttons harder to second position to engage second speed for those cranes having two-speed motors.

Always turn system OFF by pressing the OFF (ON/OFF) button on the transmitter when done with crane operation.

In an emergency always hit E-STOP (EMS) immediately. To clear the emergency condition, turn the transmitter OFF and ON again to resume normal operation.

The receiver will time-out after approximately 15 minutes if there is no activity. The transmitter is programmed to time-out if not used for 15 minutes also.

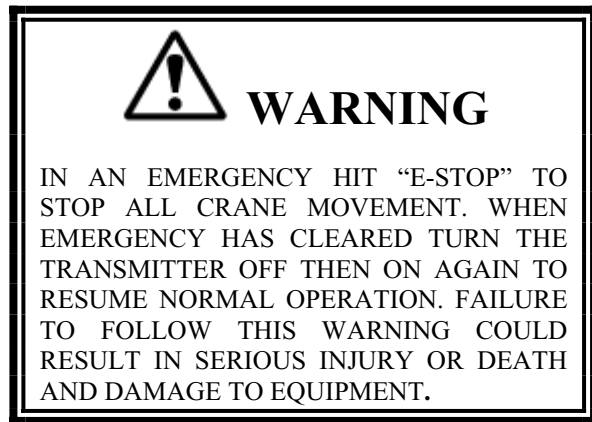

5-4. Battery Replacement.

To replace the batteries, turn transmitter over to access back cover. Twist half moon shaped battery latch to remove cover. Take out old batteries; replace ALL batteries with new cells. For the Membrane Transmitter note battery orientation, batteries in backwards will blow fuse. Replace cover and turn transmitter ON to use. See [Section 9. Spare Parts](#) for battery and fuse part numbers.

Section 6 – Wiring

6-1. Wiring Diagrams.

The following pages in this section have individual wiring diagrams for different crane configurations. Find the appropriate wiring diagram and set the Configuration Switch (SW3 in the receiver) in the appropriate receiver(s) to match the SW3 Receiver Configuration Switch settings shown in the diagram. The location of the Configuration Switch is shown in [Figure 8-1. Receiver Layout](#). Terminal designators are marked on the wiring diagram corresponding to designators found on the Receiver Board. For terminal locations see [Figure 8-1. Receiver Layout](#). The proper connections to use for the bridge and for the trolley are best determined by that pair of directional designators (North/South or East/West) best describes the crane's movement. Does the bridge travel East/West or North/South? The trolley would use the other directional pair as the bridge. Care should be taken after a directional pair is selected to make sure the specific motor directional inputs match the desired direction of the bridge or trolley, i.e., if North/South is picked for the bridge make sure the South traveling bridge motor directional is wired to the South terminal of the unit.

Typically in the following wiring diagrams, the bridge is shown as E/W (East/West) and Trolley as N/S (North/South). Since the labeling cannot be easily moved on the Membrane Transmitter keypad, the two directional pairs can be easily exchanged by turning the dipswitch SW3 position 1 in the Membrane Transmitter to "ON". See [Section 8-2.6. Repositioning of Membrane Transmitter Motion Switch Functions](#) for more details.

6-2. Installation.

Follow [Section 4. Installation Information](#) for instructions on how to install the receiver.

6-3. Alarms and Horns.

Make sure that the installation includes the proper alarms, horns, indicator lights and their associated controls as required by local and governmental regulations.

6-4. Membrane Transmitter Wiring.

The wiring diagrams output connections shown in the following pages match the nomenclature

on the single and Two-Speed Membrane per their respective diagrams.

6-5. Single-Speed Pendant Transmitter Wiring.

For the Single-Speed Pendant Transmitter the only wiring configuration is the diagram in [Figure 6-9. 10K6 Single Receiver with Single-Speed Pendant, Single-Speed Bridge, Trolley and Hoist](#).

6-6. Two-Speed Pendant Transmitter Wiring.

For the Two-Speed 10K12 Pendant Transmitter the functional labeling is different than the Two-Speed Membrane. E/W and N/S are exchanged. By setting dipswitch SW3 position 1 in the "ON" position the pushbuttons of the Pendant Transmitter match the directional notations on the two-speed wiring diagrams in [Section 6. Wiring](#). Failure to turn switch SW3 position 1 to "ON" will cause EAST/WEST and NORTH/SOUTH to be exchanged respectively. All other functions will remain the same.

6-7. Relay Sequencing

When the second speed position is activated the appropriate directional relay is still engaged.

6-8. Connecting Outputs to Drives.

MOV's (transient protectors) are on all the output relays to protect the relays from power surges. MOV's allow a small leakage current that can affect some high impedance circuits. When connecting output relays to drives, it may be required to remove the MOV to prevent the leakage current through the MOV from holding in the drive. See [Figure 8-1. Receiver Layout](#) for the location of the MOV's. The MOV's are numbered correspondingly to the relays they protect. The MOV's can be cut out of the circuit with a wire cutter. Remember to do this with ALL power OFF on the crane and all associated controls.

Section 6 - Wiring (Continued)

6-9. Legend

The following is the legend for the wiring diagrams:

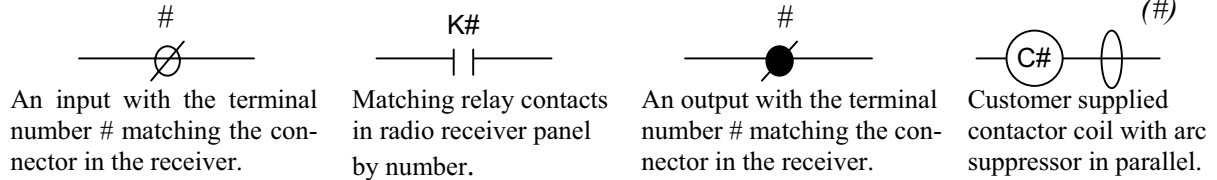
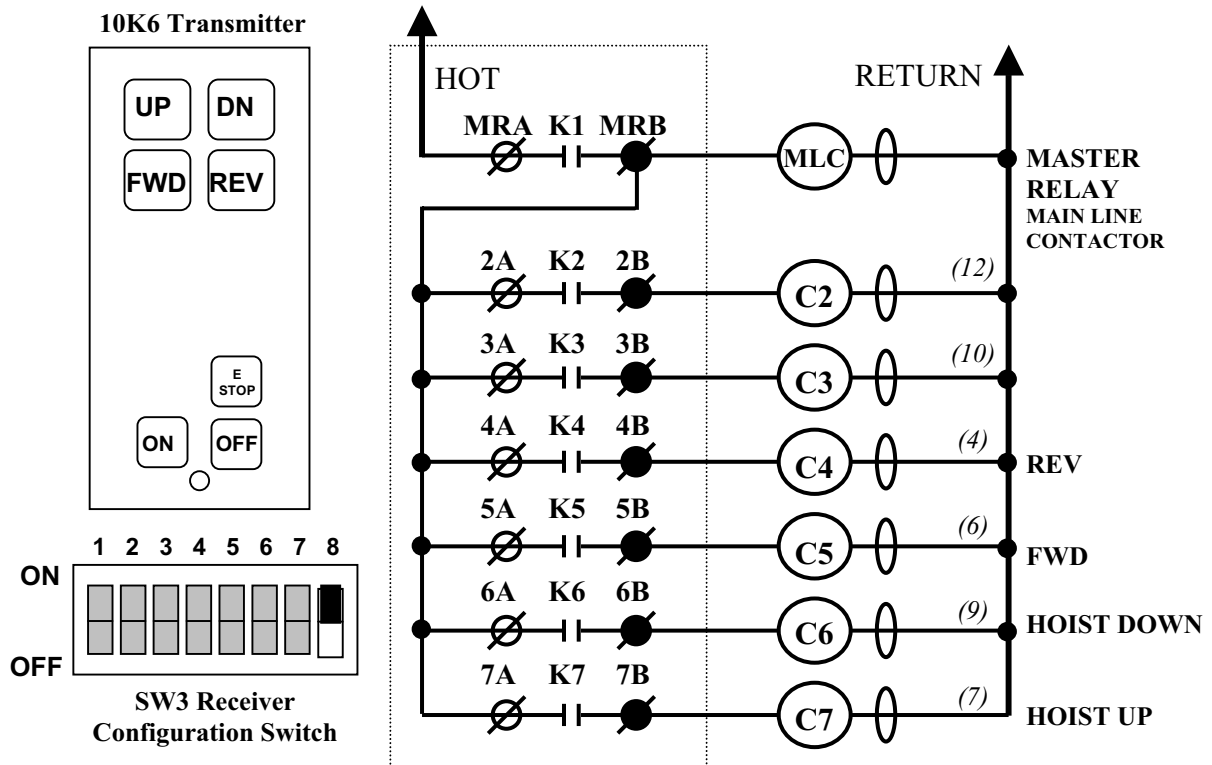

Figure 6-1. Legend.

Figure 6-2. 10K6, Single Receiver, Two Motor Interface Single-Speed*.



***NOTE**

CHECK GOVERNMENTAL AND LOCAL REGULATIONS ON THE REQUIREMENTS OF HORNS OR ALARMS BEFORE USING THIS CONFIGURATION, AS THERE IS NOT A SEPARATE ALARM CONTROL.

Section 6 – Wiring (Continued)

Figure 6-3. 10K6, Single Receiver, Two Motor Interface Two-Speed*.

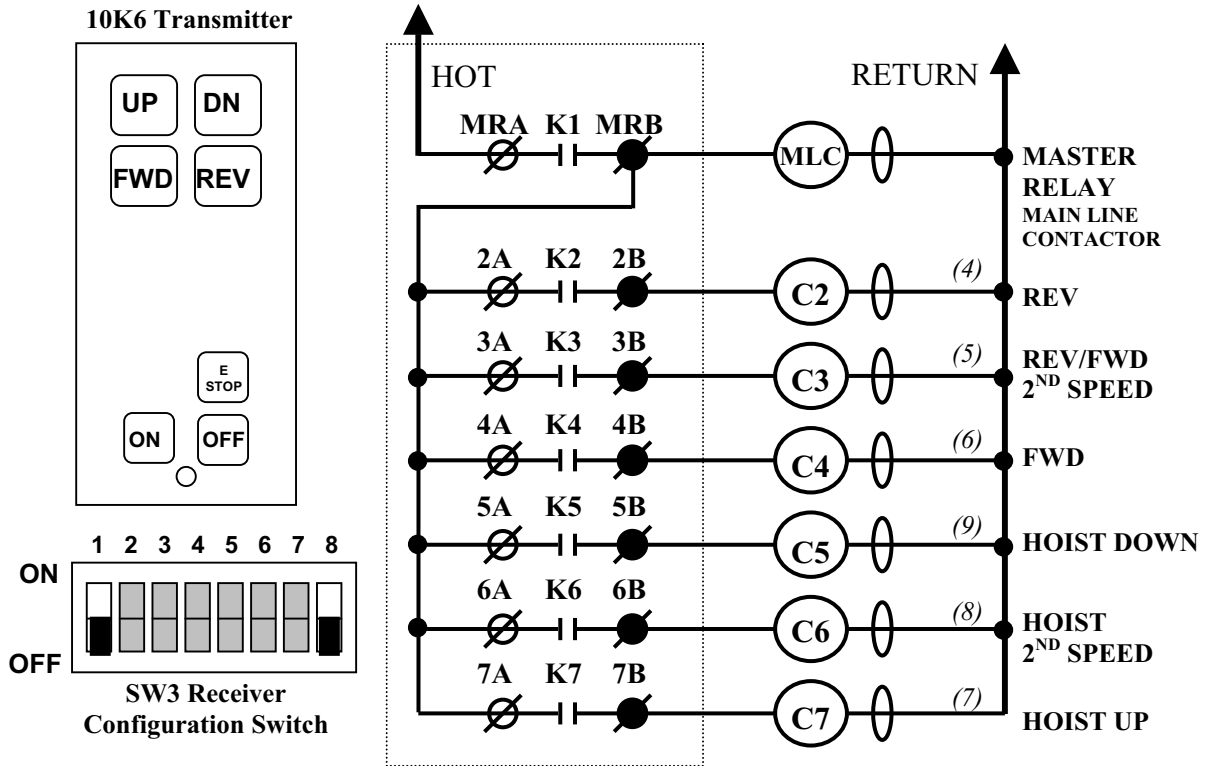

***NOTE**

CHECK GOVERNMENTAL AND LOCAL REGULATIONS ON THE REQUIREMENTS OF HORNS OR ALARMS BEFORE USING THIS CONFIGURATION, AS THERE IS NOT A SEPARATE ALARM CONTROL.

Section 6 – Wiring (Continued)

Figure 6-4. 10K9, Two Receivers, Two-Speed North/South Bridge, Single-Speed East/West Trolley and Hoist.

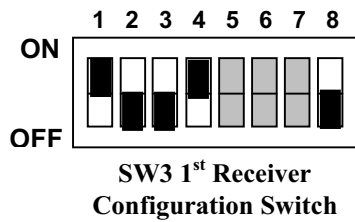

NOTE
FOR MEMBRANE TRANSMITTERS THE OUTPUTS MATCH THE DIRECTIONS INDICATED ON THE KEYS, I.E., E = EAST, W = WEST, N = NORTH, ETC.

For Slider style transmitters with changeable lettering see the diagram below and match the position with the letter (X) to the right of the wiring output label.

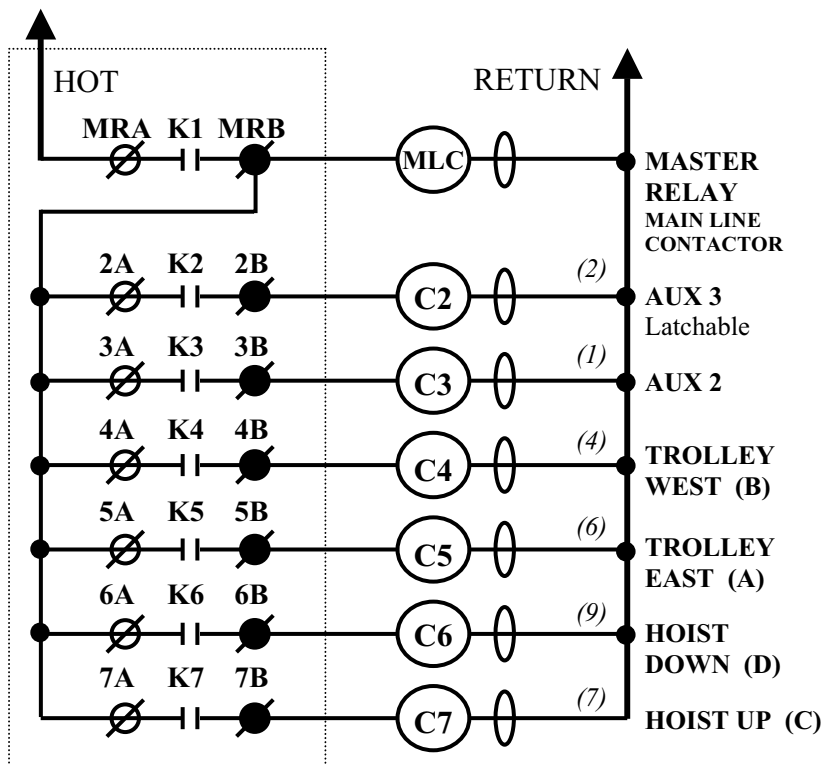
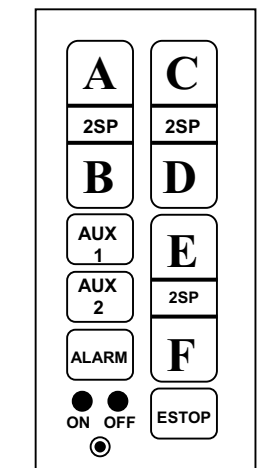
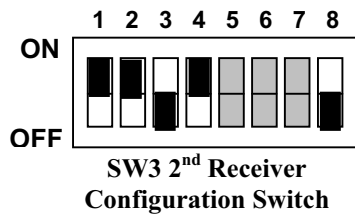
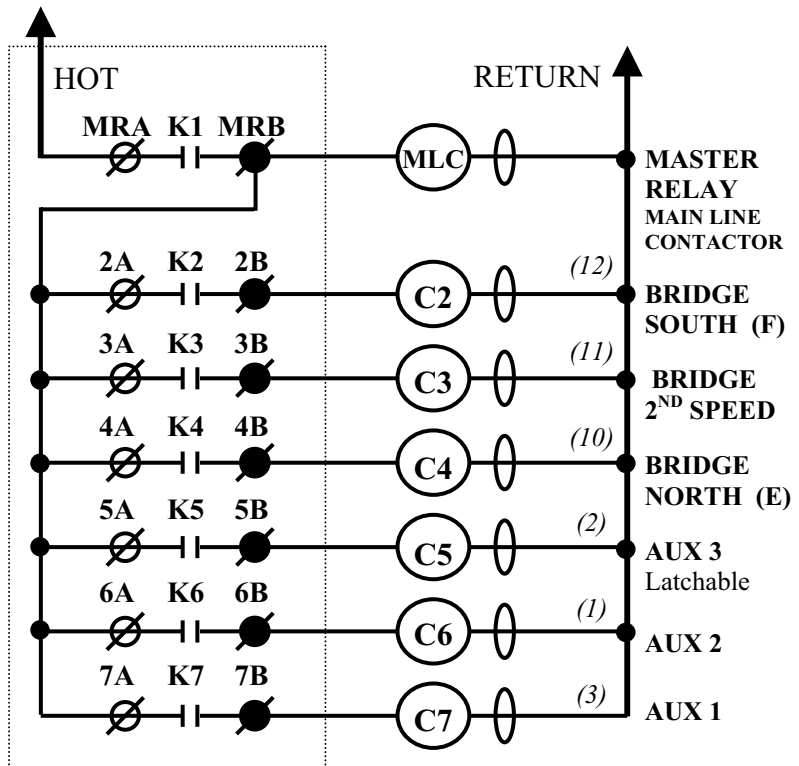

Section 6 – Wiring (Continued)

Figure 6-5. 10K9, Two Receivers, Two-Speed North/South Bridge, East/West Trolley and Hoist.

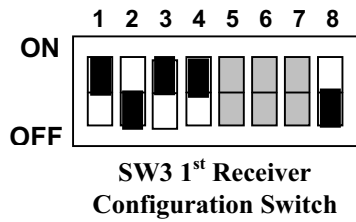

NOTE
FOR MEMBRANE TRANSMITTERS THE OUTPUTS MATCH THE DIRECTIONS INDICATED ON THE KEYS, I.E., E = EAST, W = WEST, N = NORTH, ETC.

For Slider style transmitters with changeable lettering see the diagram below and match the position with the letter (X) to the right of the wiring output label.

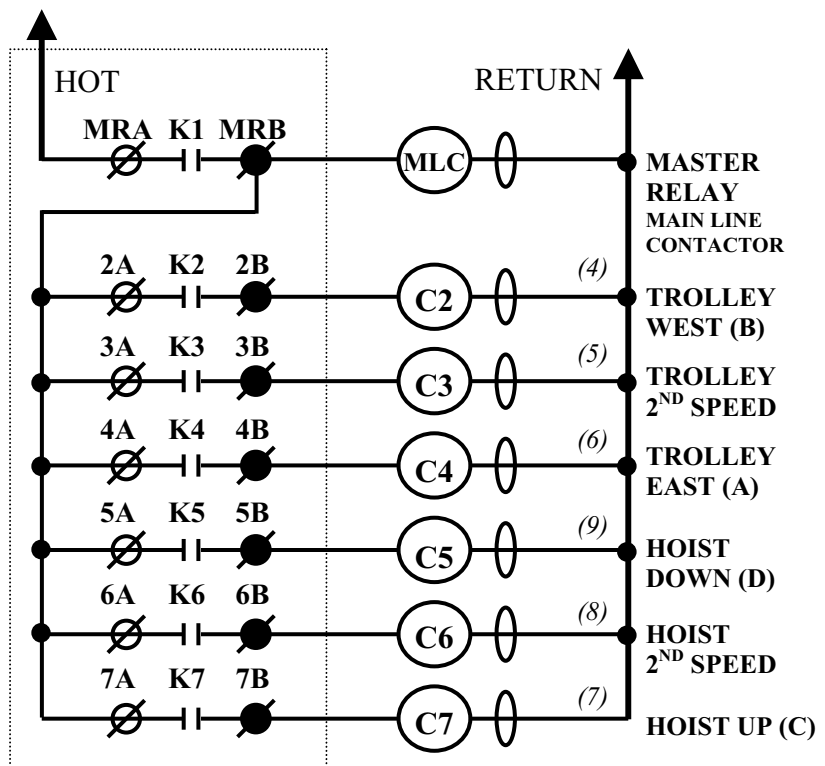
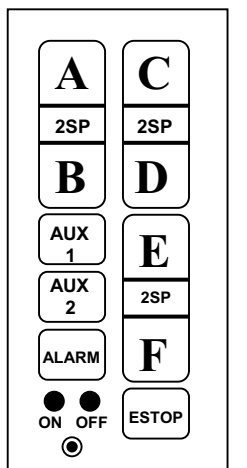
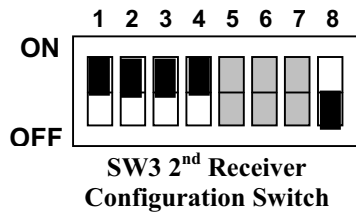
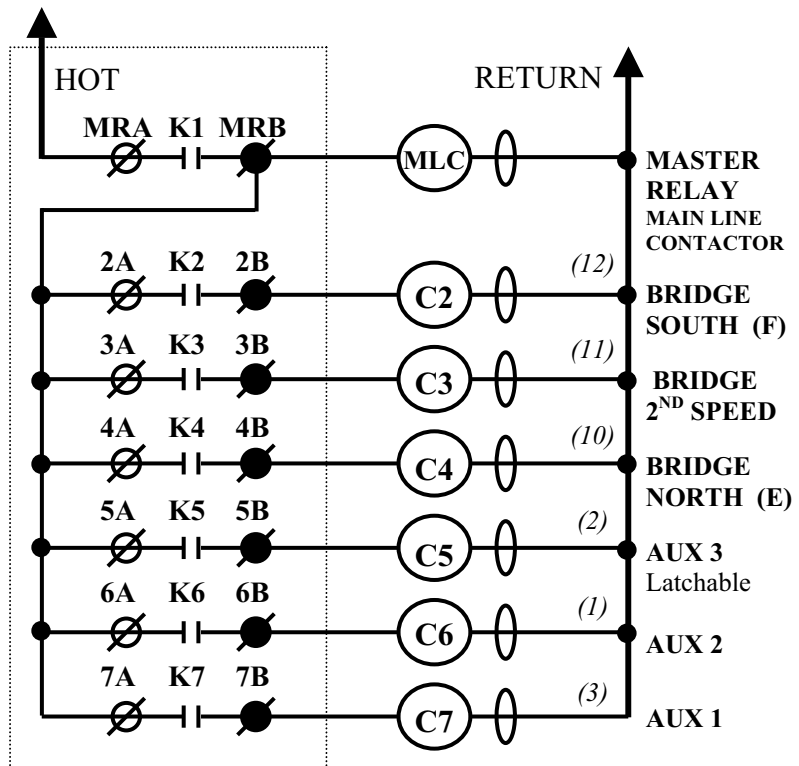

Section 6 – Wiring (Continued)

Figure 6-6. 10K9, Two Receivers, Two-Speed East/West Bridge, Single-Speed North/South Trolley and Hoist.

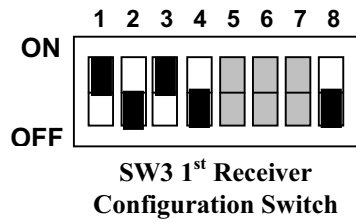

NOTE
FOR MEMBRANE TRANSMITTERS THE OUTPUTS MATCH THE DIRECTIONS INDICATED ON THE KEYS, I.E., E = EAST, W = WEST, N = NORTH, ETC.

For Slider style transmitters with changeable lettering see the diagram below and match the position with the letter (X) to the right of the wiring output label.

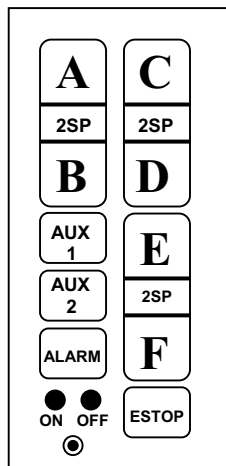
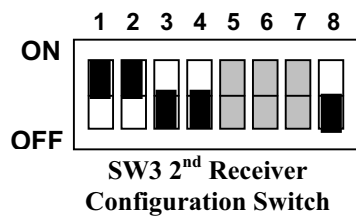
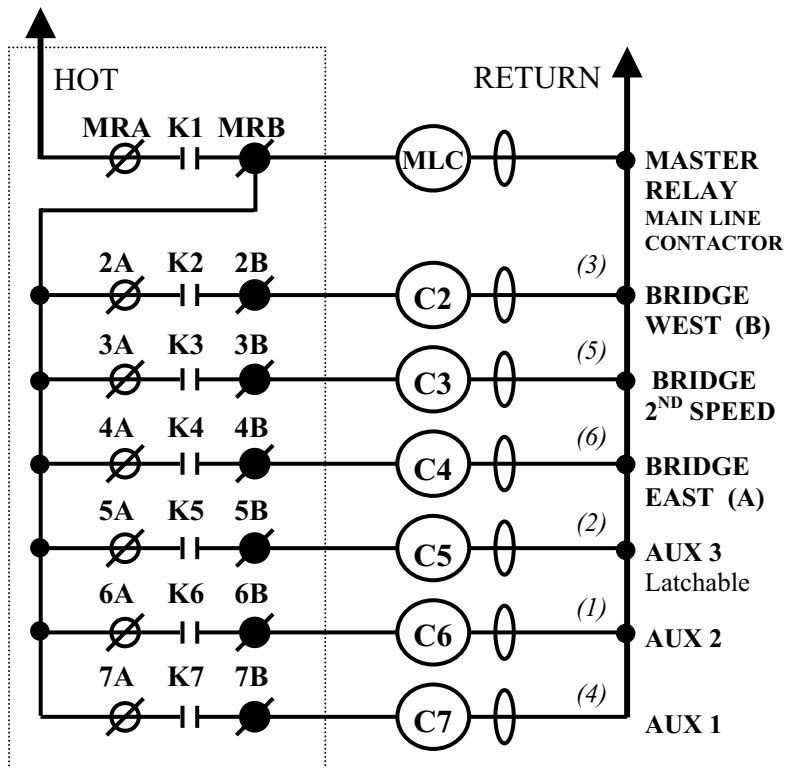

Slider Key Designators

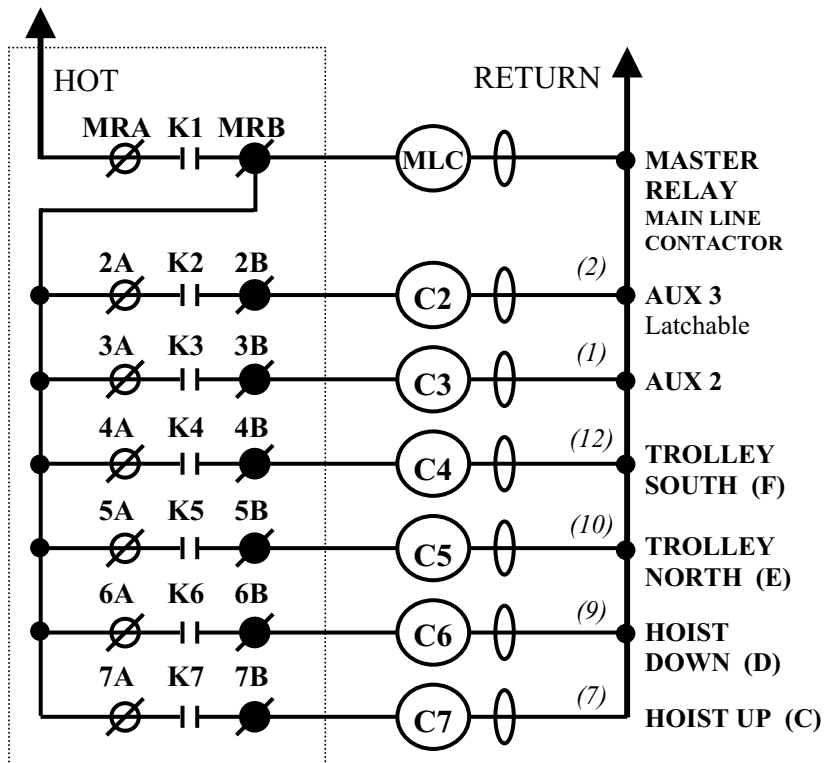

Section 6 – Wiring (Continued)

Figure 6-7. 10K9, Two Receivers, Two-Speed East/West Bridge, North/South Trolley and Hoist.

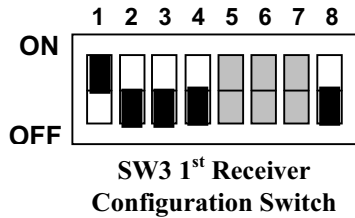

NOTE
FOR MEMBRANE TRANSMITTERS THE OUTPUTS MATCH THE DIRECTIONS INDICATED ON THE KEYS, I.E., E = EAST, W = WEST, N = NORTH, ETC.

For Slider style transmitters with changeable lettering see the diagram below and match the position with the letter (X) to the right of the wiring output label.

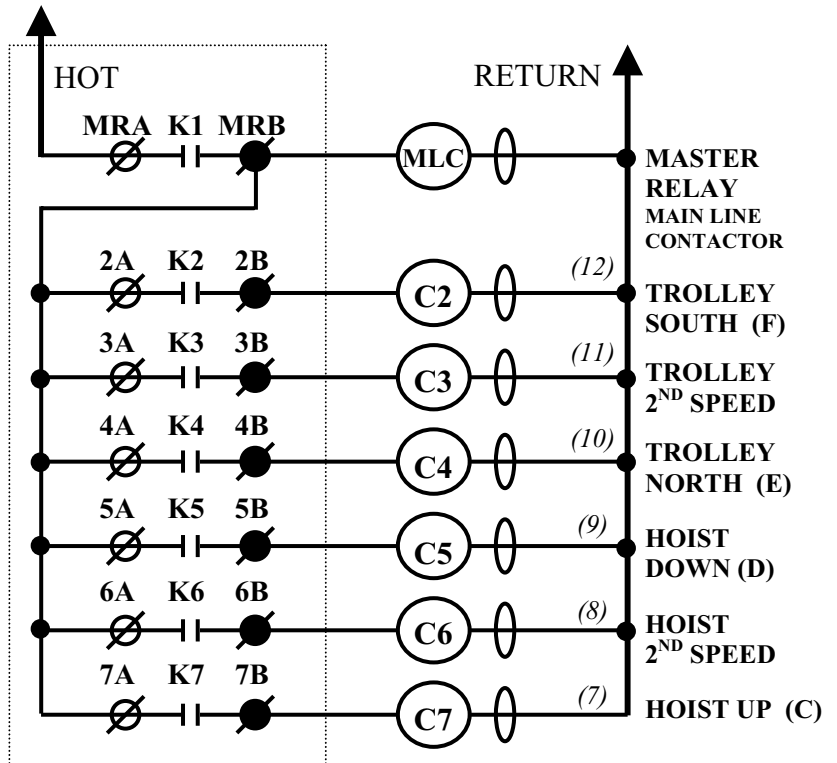
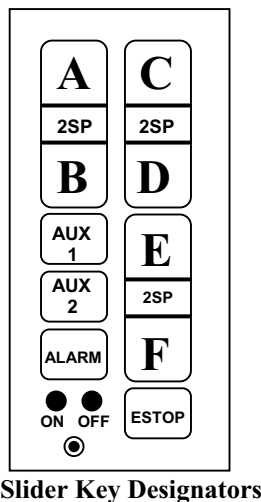
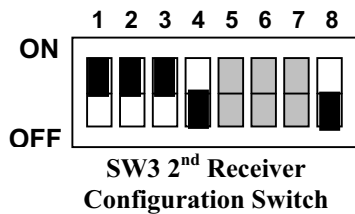
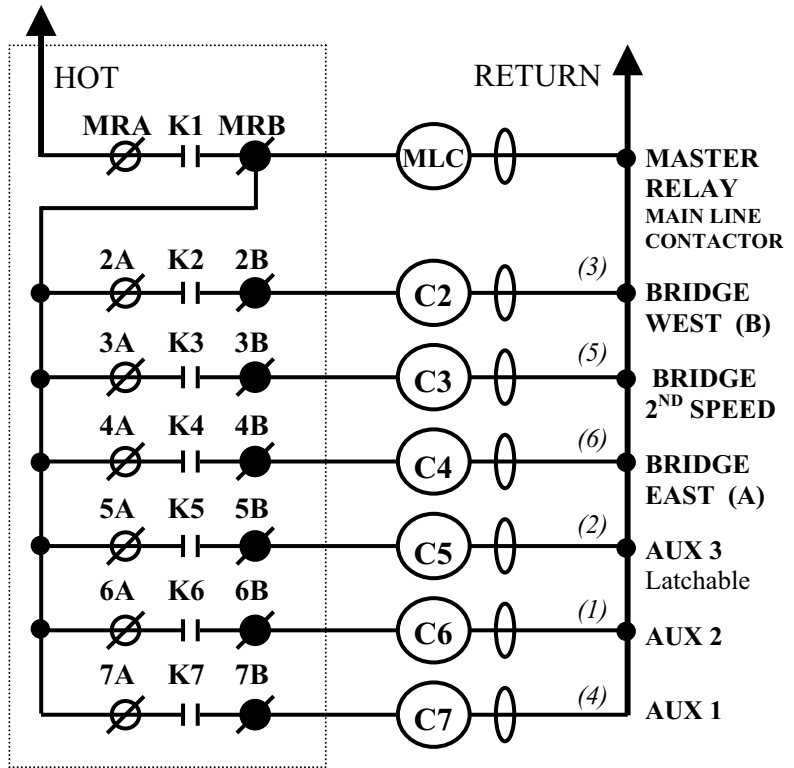

Section 6 – Wiring (Continued)

Figure 6-8. 10K6, Single Receiver, Single-Speed Bridge, Trolley and Hoist*.

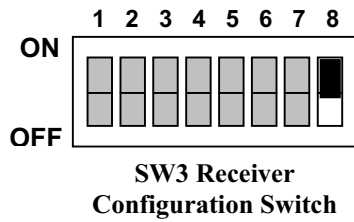

NOTE
FOR MEMBRANE TRANSMITTERS THE OUTPUTS MATCH THE DIRECTIONS INDICATED ON THE KEYS, I.E., E = EAST, W = WEST, N = NORTH, ETC.

For Slider style transmitters with changeable lettering see the diagram below and match the position with the letter (X) to the right of the wiring output label.

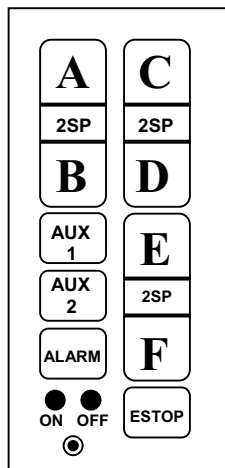

Slider Key Designators

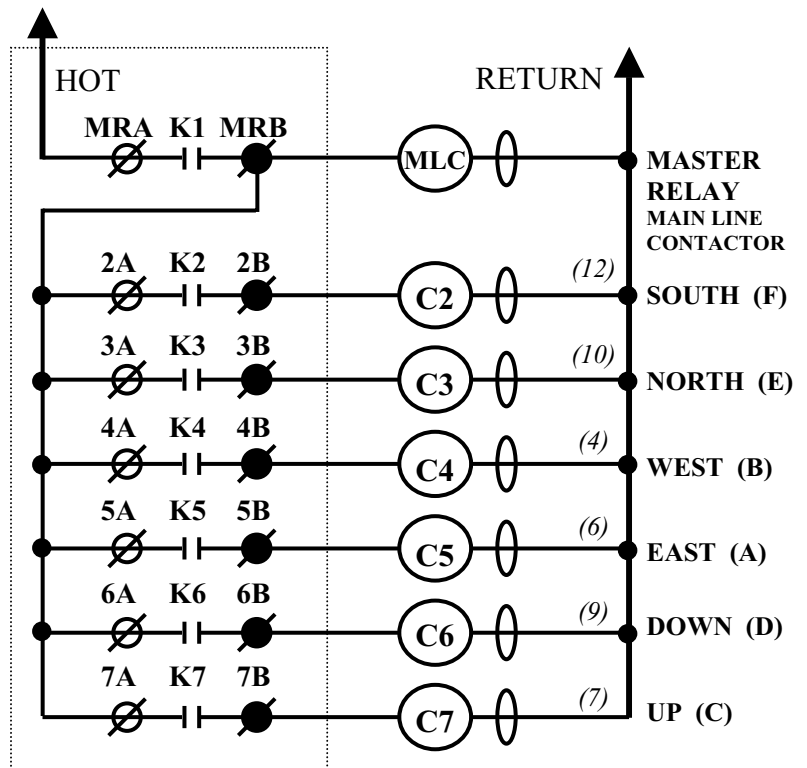

***NOTE**
CHECK GOVERNMENTAL AND LOCAL REGULATIONS ON THE REQUIREMENTS OF HORNS OR ALARMS BEFORE USING THIS CONFIGURATION, AS THERE IS NOT A SEPARATE ALARM CONTROL.

Section 6 – Wiring (Continued)

Figure 6-9. 10K6, Single Receiver with Single-Speed Pendant, Single-Speed Bridge, Trolley and Hoist*.

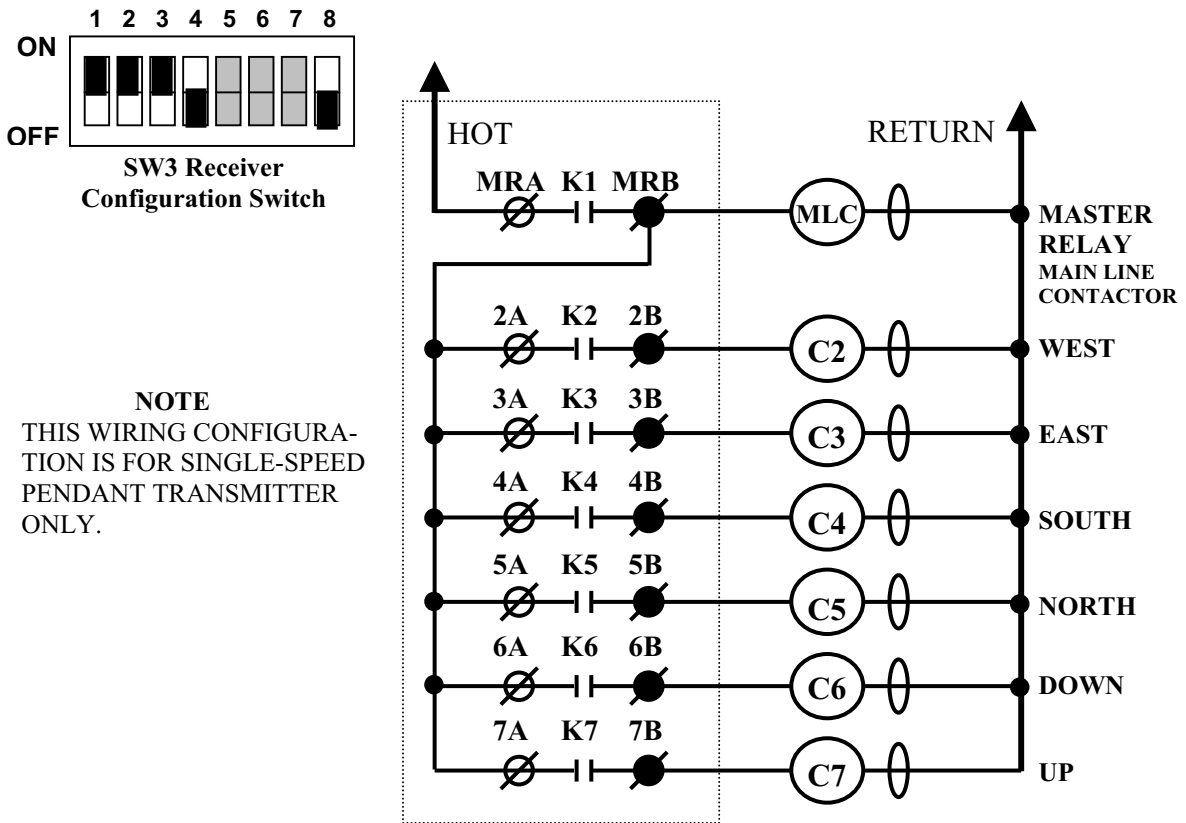

***NOTE**

CHECK GOVERNMENTAL AND LOCAL REGULATIONS ON THE REQUIREMENTS OF HORNS OR ALARMS BEFORE USING THIS CONFIGURATION, AS THERE IS NOT A SEPARATE ALARM CONTROL.

Section 6 – Wiring (Continued)

This page intentionally left blank.

Section 7 – Access Code and Receiver Programming

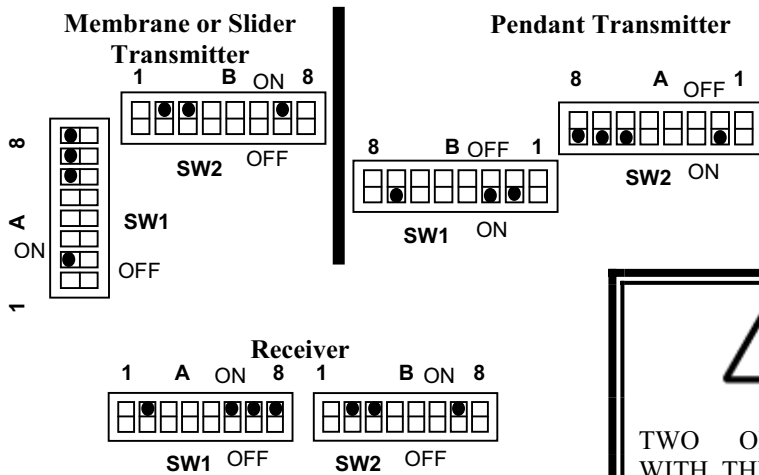

Access Code Switches
Sample access code only do not use

MODEL # -10XXXXXXXXXX
 S/N=XXXXXXXXXXXXXXXXXX
 ACCESS CODE SETTING
1 A 8 1 B 8
 0 1 0 0 0 1 1 1 0 1 1 0 0 0 1 0
 FREQ := AK01 J# = XXXXX

Sample Transmitter Access Code Label
Sample access code only do not use

Figure 7-1. Access Code Setting.
 (A dot on a switch position or a "1" in the label is an indication that the respective switch position should be ON).

7-1. Programming Access Codes.

The access code is set at the factory and should not be changed unless absolutely necessary. If you are reprogramming a spare or new transmitter make sure the other transmitter is securely taken out of service.

Also a label on the transmitter lists the access code settings inside. The positions on the transmitter label match the switch settings. The "1" by A1 means the switch position A1 should be "ON" and "0" means A1 should be "OFF".

WARNING

TWO OPERATIONAL TRANSMITTERS WITH THE SAME ACCESS CODES OPERATING AT THE SAME TIME IS A DEFINITE SAFETY HAZARD. FAILURE TO FOLLOW THIS WARNING COULD RESULT IN SERIOUS INJURY OR DEATH AND DAMAGE TO EQUIPMENT.

For Membrane and Slider transmitters the access code positions A1-A4 can be accessed through the battery compartment.

7-2. Changing Transmitter Access Codes.

WARNING

AFTER CHANGING THE ACCESS CODES ON THE TRANSMITTER, TEST THE UNIT BY TURNING IT ON AND OFF NEAR THE APPROPRIATE RECEIVER. IF THE RECEIVER DOES NOT RESPOND, DO NOT ACTIVATE A FUNCTION BUTTON! THE TRANSMITTER MAY HAVE THE WRONG ACCESS CODE, WHICH COULD MOVE ANOTHER CRANE. RE-CHECK THE ACCESS CODE IN THE TRANSMITTER AND RETEST. FAILURE TO FOLLOW THIS WARNING COULD RESULT IN SERIOUS INJURY OR DEATH AND DAMAGE TO EQUIPMENT.

7-2.1. Membrane and Slider Transmitter Access Code Setting.

Open the back battery door and take out the batteries as a safety precaution.

Section 7 – Access Code and Receiver Programming (Continued)

Remove the 6 screws on the front cover. Lift out switch-pad, logic board and turn logic board over.

Locate the dipswitches marked “A” and “B”. See [Figure 8-3. Membrane Transmitter M/C Module E10635](#). With a pen or pointed object toggle the switches to match the Access Code on the receiver. A dot on the switch diagram means that switch position is ON.

NOTE

DO NOT USE A PENCIL TO TOGGLE THE SWITCHES. THE LOOSE GRAPHITE FROM THE PENCIL CAN DAMAGE THE SWITCH.

Reassemble unit; replace the batteries and test.

7-2.2. Pendant Transmitter Access Code Setting.

Open the back battery door and take out the batteries as a safety precaution.

Remove the 8 screws on the front cover. Turn transmitter over and remove back cover.

Locate the dipswitches marked “A” and “B”. See [Figure 8-6. Pendant Transmitter M/C Module E10636](#). With a pen or pointed object toggle the switches to match the Pendant Transmitter Code Diagram on the door of the receiver. A dot on the switch diagram means that switch position is ON.

Reassemble unit; replace the batteries and test.

7-3. Receiver Access Code Setting.

The access code is preset at the factory and should not be changed unless absolutely necessary. The access code switches are labeled “A” and “B”. See [Figure 8-1. Receiver Layout](#) for switch location.

The programming in the receiver(s) must match the transmitter. If looking at the label on the outside of the transmitter, take note that positions “A” and “B” number from the left 1 through 8. Be sure to program the access codes the same in both receivers for a 10K9 system.

NOTE

IN EVENT PROGRAMMING OF ACCESS CODES IS REQUIRED, TAKE SPECIAL

CARE TO CORRECTLY LOCATE ACCESS CODE SWITCHES A AND B. LOOK FOR THE LABELS A AND B ON THE PRINTED CIRCUIT BOARD NEAR THE RESPECTIVE SWITCHES. DETERMINE THEIR ORIENTATION. THE SWITCHES MAY NUMBER FROM LEFT TO RIGHT OR RIGHT TO LEFT. LOOK FOR THE NUMBERING ON THE SWITCHES. MATCH ACCESS CODES A1, A2, - - B1, B2 ETC. MAKE SURE THE ACCESS CODES IN BOTH RECEIVERS (FOR A 10K9 SYSTEM) MATCH.

After changing the access code, test the receiver (s) with a matching transmitter. (If the red LED DS9 comes ON in either receiver the code does not match, recheck the access code settings.)

7-4. Latchable Auxiliaries.

Auxiliary relay “AUX 3” can be made latchable by setting in the receiver SW3 position 5 to ON. This function should not be used for critically maintained functions like magnets or pumps for safety reasons. Check the respective wiring diagram in [Section 6. Wiring](#) for the appropriate position and function. See [Figure 8-1. Receiver Layout](#) for SW3 location. Always verify operation before putting crane in service.

7-5. Receiver Time-out-timer.

The receiver ships standard with a 15-minute time-out-timer. To disable the time-out-timer the receiver EPROM must be replaced. (For 10K9 systems both EPROMs must be replaced. The part numbers for the two EPROM's are:

FW2824-1T EPROM with 15-minute time-out.
FW2824-1N EPROM without time-out.

See [Figure 8-1. Receiver Layout](#) for location of receiver EPROM. If disabling the receiver time-out-timer, remember to also disable the time-out-timer in the transmitter. See [Section 8-2. Membrane Transmitter](#) or [8-3. Pendant Transmitter](#) for details.

7-6. Transmitter Programming (Other).

For most configurations of the Membrane, Slider and Pendant Transmitter dipswitches SW3 and SW4 should all be OFF. These are transmitter-programming switches (not the access code switches) in both types of transmitters.

Section 7 – Access Code and Receiver Programming (Continued)

For additional transmitter programming information see [Section 8. Servicing and Transmitter Programming.](#)

7-7. Multibox

7-7.1. Multibox Operation.



WARNING

IF YOUR UNIT WAS NOT ORDERED WITH MULTIBOX DO NOT ATTEMPT TO PROGRAM MULTIBOX IN THE FIELD. TELEMOTIVE MUST COORDINATE ACCESS CODE ASSIGNMENTS WITH THE TRANSMITTERS PRIOR TO ENABLING MULTIBOX. PLEASE CONTACT TELEMOTIVE IF YOU NEED TO ADD MULTIBOX. FAILURE TO FOLLOW THIS WARNING COULD RESULT IN SERIOUS INJURY OR DEATH AND DAMAGE TO EQUIPMENT.



WARNING

IF YOUR UNIT HAS MULTIBOX DO NOT ATTEMPT TO PROGRAM ADDITIONAL TRANSMITTERS IN THE FIELD. TELEMOTIVE MUST COORDINATE ACCESS CODE ASSIGNMENTS WITH THE NEW TRANSMITTERS PRIOR TO EXPANDING MULTIBOX. PLEASE CONTACT TELEMOTIVE IF YOU NEED TO ADD ADDITIONAL TRANSMITTERS. FAILURE TO FOLLOW THIS WARNING COULD RESULT IN SERIOUS INJURY OR DEATH AND DAMAGE TO EQUIPMENT.

The 10K6/9 has Multibox capability that allows up to 4 transmitters to access a single system. Only one transmitter may control the receiver(s) at a given time. Access is on a first come first serve basis. Once a transmitter has gained control, another transmitter may not access the receiver(s) until the controlling transmitter relinquishes control by transmitting an OFF command to the receiver(s) or the receiver(s) times out due to inactivity.

The first transmitter to send an ON command after the receiver has been released will then gain control of the receiver(s). The number of transmitters (1-4) allowed to control the receiver(s) is dipswitch selectable on the Receiver CPU Board.

Special software (EPROM) is required in the Receiver CPU Board to implement Multibox. For 10K9 Systems both receivers require special software.

NOTE

THE DESIRED MULTIBOX TRANSMITTERS MUST HAVE CONSECUTIVE ACCESS CODES BEGINNING FROM THE FIRST ACCESS CODE.

7-7.2. SW3 Switch Multibox Settings.

Multibox. dipswitch settings on the Receiver CPU Board control the number of transmitters. This is done by the Receiver Configuration Switch SW3 (dipswitch positions 6 and 7). For 10K9 systems both receivers must have the Configuration Switch set the same. Different settings are used for 2, 3 and 4 transmitters. See [Table 7-1. Multibox Switch Settings](#) for proper Multibox settings.

The Receiver Configuration Switch, dipswitch SW3, is found on the Receiver CPU Board. See [Figure 8-1. Receiver Layout.](#)

On the transmitters sequential access codes are required. These are set on access code switch “A” positions “1”, “2” and “3” or more as required. The first transmitter uses the same access code as the receiver. The other transmitters have their access code sequentially incremented each by one extra bit. With “A1” being the least significant bit. See [Figure 7-1. Access Code Settings.](#)

For Membrane and Slider transmitters the Access code positions A1-A2 can be accessed through the battery compartment. The Pendant Transmitter requires the back to be removed.

See [Table 7-1. Multibox Switch Settings](#) below for appropriate settings for both the transmitters and receiver(s).

Section 7 – Access Code and Receiver Programming (Continued)

Table 7-1. Multibox Switch Settings.

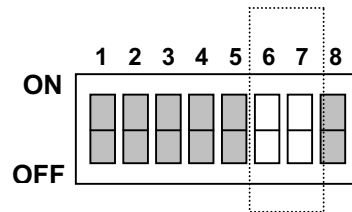

Figure 7-2. SW3 Receiver Configuration Dipswitch

Receiver (See [Figure 8-1](#)).

SW3 Switch Settings	3-6	3-7	Maximum Transmitters
OFF	OFF	OFF	1
OFF	ON	OFF	2
ON	OFF	ON	3
ON	ON	ON	4

Transmitter (See [Figure 7-1](#)).

Access Code Switch Settings
First Access Code
First Access Code + 1 bit
First Access Code + 2 bits
First Access Code + 3 bits

Section 8 – Servicing and Transmitter Programming

8-1. Receiver Servicing.

The following sections describe trouble shooting the 10K6/9 system.

NOTE

CHECK TO SEE IF 4 GREEN LED'S ARE ON. CHECK TO SEE IF DS9 FLASHES WITH TRANSMITTER COMMANDS. SEE TABLE 8-1. RECEIVER DIAGNOSTIC LED FUNCTIONS BELOW FOR DETAILS.

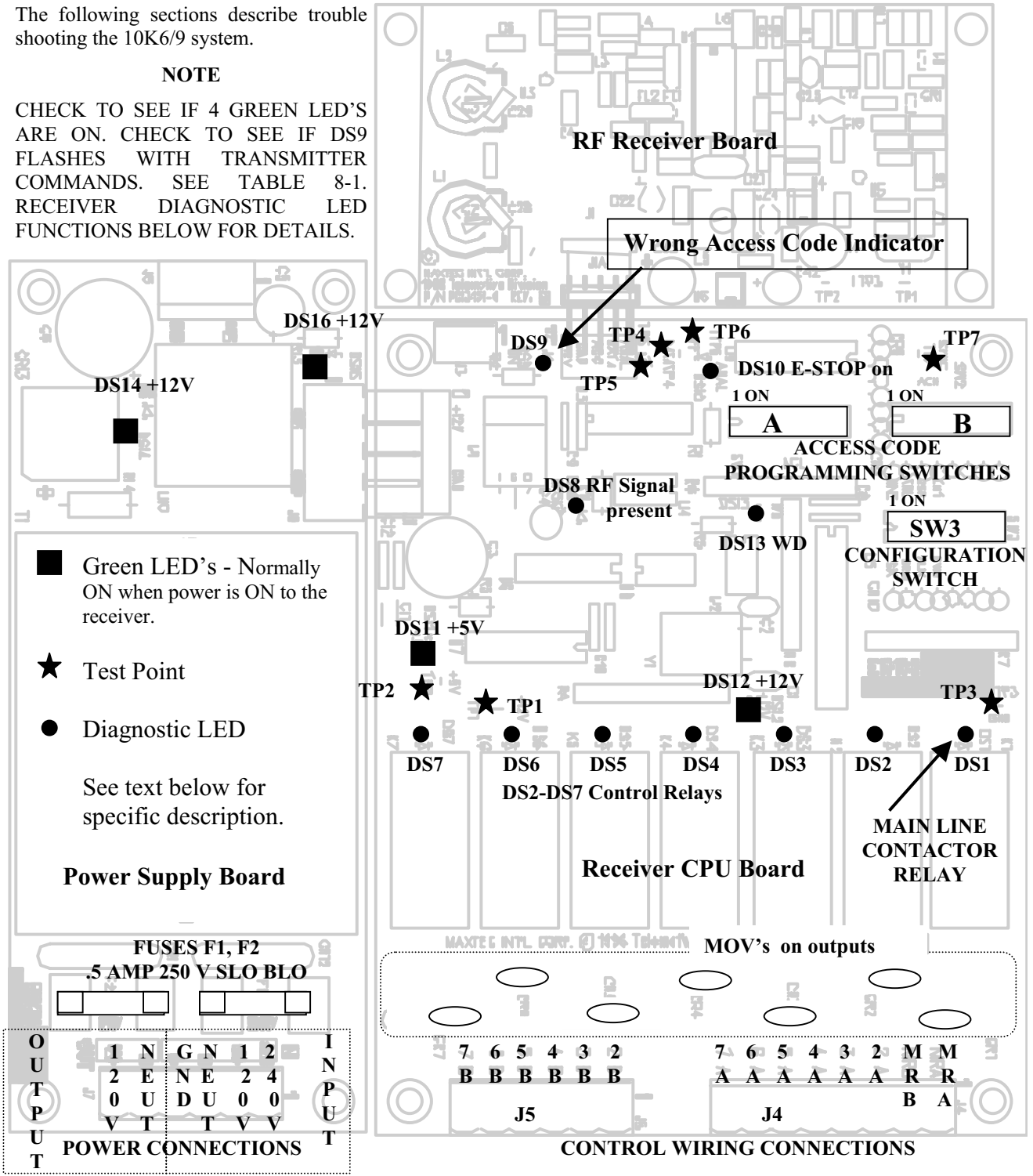

Figure 8-1. Receiver Layout.

Section 8 – Servicing and Transmitter Programming (Continued)

NOTE

IF THE SYSTEM STOPS WORKING CHECK THE LED INDICATOR ON THE TRANSMITTER. IF IT DOES NOT COME ON WITH PUSHING THE ON BUTTON REPLACE THE TRANSMITTER BATTERIES (FIVE AA CELLS ON THE MEMBRANE AND SLIDER TRANSMITTER, SEE [SECTION 9. SPARE PARTS](#) FOR PENDANT TRANSMITTER BATTERIES).

Table 8-1. Receiver Diagnostic LED Functions. (See [Figure 8-1 Receiver Layout](#) for LED locations).

LED	COLOR	FUNCTION
DS1	Red	Monitors closing of Master Relay (K1) Normally ON when the Transmitter turns ON the receiver. This LED is illuminated when the MR relay has been enabled by an ON command received from the Transmitter. The LED will extinguish, when an OFF command has been transmitted, or an E-STOP condition is present. The output relays are not functional if the MR is not engaged.
DS2-DS7	Red	Monitors closure of the output relays (K2-K7). Normally ON for a function when that specific function is enabled. The LED will be illuminated when the relay has been enabled by the respective command received from the Transmitter Unit. The LED will extinguish, when the command is no longer detected.
DS14	Green	Monitors the unregulated DC power to the 12 volt regulator Normally ON when AC line is present. If AC Power is present and the AC to DC converter is working then the LED is illuminated. The LED is off if DC power is not present. Check power supply, fuses and if power is applied to the receiver.
DS12, DS16	Green	Monitors the regulated 12 VDC power. (DS16 on the power supply and DS12 on the receiver board). Normally ON when AC line is present. If regulated 12 VDC power is present then the LED is illuminated. The LED is off if 12 VDC power is not present. Check the 12 VDC regulator, no or low line voltage and for shorts on the boards.
DS11	Green	Monitors regulated 5 VDC power to the Board. Normally ON when AC line is present. If 5 VDC power is present then the LED is illuminated. The LED is off if 5 VDC power is not present. Check the 5 VDC regulator and for shorts on the board.
DS9 In trouble-shooting check this first.	Red	Wrong Access Code (WAC). Normally OFF. This LED flashing during data transmission usually means the receiver access code does not match the transmitter. See Section 7 . to program the access codes. (If there are other Telemotive transmitters in the area this light will flash when they transmit because they are on the same frequency with a different access code. This in itself does not indicate a problem).

Section 8 – Servicing and Transmitter Programming (Continued)

DS10	Red	<p>Emergency Stop (EMS) condition</p> <p>Normally OFF.</p> <p>This LED ON continuously means the transmitter sent an E-STOP command. Send an “OFF” command from the transmitter followed by an “ON” command to clear the EMS condition.</p>
DS13	Red	<p>Watch Dog (WD) for microprocessor</p> <p>Normally OFF.</p> <p>If this LED is flashing the 5 volts to the unit is too low. Look for shorts on the Board. If the LED is ON continuously the respective microprocessor has failed. Reseat the respective EPROM chip in its socket; if this does not fix the problem replace it.</p>
DS8	Yellow	<p>RF Signal Received</p> <p>Flashes while the transmitter is sending commands. (After the receiver has been turned on by the transmitter hold down a function button on the transmitter).</p> <p>When a transmitter is sending data this LED should flash indicating the reception of data. If the red LED DS9 comes on at the same time the access code does not match. If the receiver is ON and no new lights come on during transmissions by the transmitter (holding a button down) check to see if the transmitter light is flashing. If the transmitter LED is not flashing then replace the batteries, turn transmitter ON again and retest. If the transmitter LED is rapidly flashing when a button is pressed and there are no new LEDs lit in the receiver, the RF Receiver Module should be replaced.</p>

8-1.1. Receiver Test Points.

Test points are shown as stars on [Figure 8-1. Receiver Layout.](#)

TP1 – Monitors regulated 12VDC. Should measure +12 Volts DC.

TP2 – Monitors regulated 5VDC. Should measure +5 Volts DC.

TP3 – Ground for monitoring other test points.

NOTE

THE FOLLOWING TEST POINTS NEED AN OSCILLOSCOPE, SEE 8-1.2. TYPICAL WAVE FORMS ON AN OSCILLOSCOPE BELOW.

TP4 – Monitors received data from RF Receiver module.

TP5 – Monitors AGC (Automatic Gain Control) from RF Receiver module.

TP6 – Monitors analog signal from RF Receiver module.

TP7 – Monitors sync signal when good data is detected.

Section 8 – Servicing and Transmitter Programming (Continued)

8-1.2. Typical Wave Forms on an Oscilloscope.

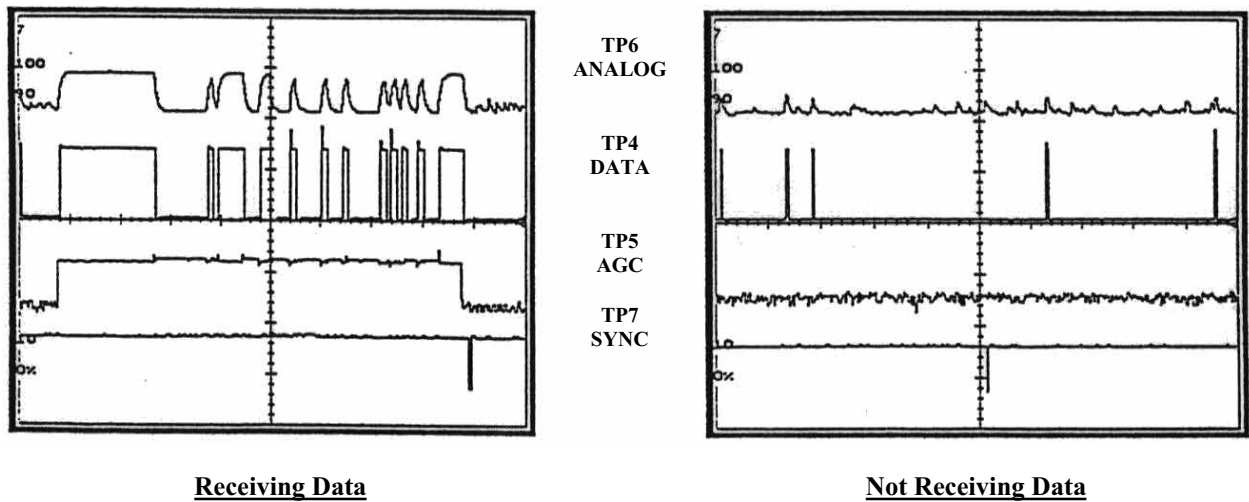

Figure 8-2. Receiver Scope Wave Forms.

Scope Settings:

- Sweep – 1 millisecond per division.
- Sensitivity – TP6 1 volt per division 10X probe.
TP4 2 volts per division 10X probe.
TP5 1 volt per division 10X probe.
TP7 5 volts per division 10X probe.

Section 8 – Servicing and Transmitter Programming (Continued)

8-2. Membrane Transmitter Servicing and Programming.

The Membrane Transmitter M/C board is shown in [Figure 8-3](#). Refer to paragraphs below for Servicing Procedures.

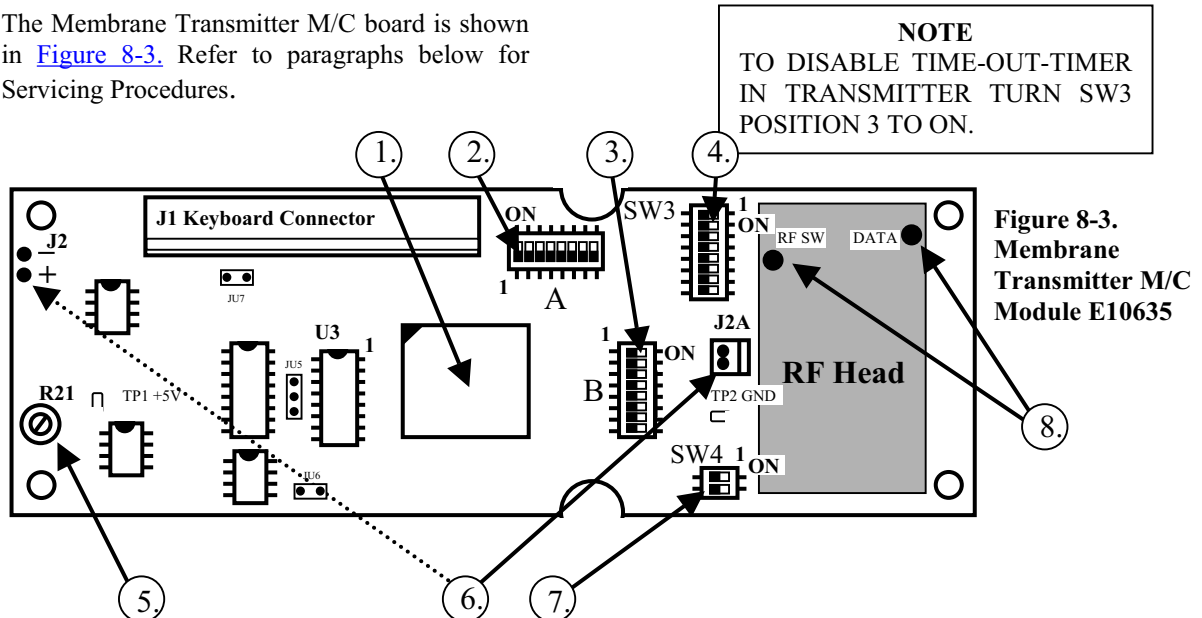

- 1.) EPROM FW2903-0.
- 2.) SW1 "A" Access Code Switch.
- 3.) SW2 "B" Access Code Switch.
- 4.) SW3 Two-Speed Mode Switch.
- 5.) Battery Monitor Adjustment. Set for 5.8 Volts.
- 6.) Battery Cable Connections, J2A plug and J2 alternate style.
- 7.) SW4 Single-Speed Mode Switch.
- 8.) Data check points.

8-2.1. Membrane Transmitter Switch Settings.

SW3

Position Controls

- 1-3 Switch positioning. See [Section 8-2.6](#).
- 4 ON disables Transmitter Time-out-timer
- 5-7 Not used on 10K6/9. All positions should be set to OFF.
- 8 No function. Should be set to OFF.

SW4

Position Controls

- 1-2 Mode Select See [Section 8-4.5](#).

8-2.1.1. SW3 Positions 1-3 Switch Positioning. (Standard configuration all "OFF").

If replacing a Pendant Transmitter with a Membrane Transmitter on an existing installation or to making them interchangeable and keeping the existing receiver wiring, open

the Membrane Transmitter, find dipswitch SW3 and move position 1 (SW3) to "ON". See [Figure 8-3. Membrane Transmitter M/C Module E10635](#). The Membrane Transmitters labeling and functions North and South, East and West will match the Pendant Transmitter.

NOTE

TRANSMITTER SW4 POSITIONS 1-2 MUST BE SET TO "OFF" (TWO-SPEED) FOR SWITCH POSITIONING TO FUNCTION.

FOR THE TWO-SPEED MEMBRANE TRANSMITTER, THE FUNCTIONAL POSITIONS OF THE VARIOUS BUTTONS CONTROLLING THE HOIST, BRIDGE AND TROLLEY CAN BE MOVED BY TRANSMITTER DIPSWITCH SW3 POSITIONS SW3-1 THROUGH SW3-3. NO CHANGE IN RECEIVER WIRING IS NEEDED TO USE THESE FUNCTIONS. SEE [SECTION 8-2.6](#).

Section 8 – Servicing and Transmitter Programming (Continued)

REPOSITIONING OF MEMBRANE TRANSMITTER MOTION SWITCH FUNCTIONS FOR SWITCH VERSUS BUTTON CONFIGURATIONS.

8-2.1.2. SW3 Position 4 Time-out-timer Disable. (Normally keep turned “OFF”).

The transmitter has an approximate 15-minute time-out-timer. If the transmitter is not used for over 15 minutes it will shut down. This transmitter time-out-timer function is transmitter dipswitch selectable. SW3 position 4 disables the time-out-timer. Turning SW3-8 “ON” disables the time-out-timer. If disabling the transmitter time-out-timer, remember to also replace the receiver(s) EPROM(s) to disable the time-out-timer in the receiver. See [Section 7-5. Receiver Time-out-timer for details.](#)

8-2.1.3. SW3 Positions 5-7 Extended Crane Control Configurations. (Standard all “OFF”).

Extended Crane Control Options for 10K12 Two-Speed Membrane Transmitter are not used for the 10K6/9 Receivers.

8-2.1.4. Transmitter Programming SW4 Positions 1-2 Mode Enable. (All two-speed configurations all “OFF”).

Mode 0, SW4 1 turned “OFF” and SW4 2 turned “OFF”. From the factory the standard Two-Speed Membrane Transmitter is configured this way. This mode in the Membrane Transmitter is for all two-speed applications. If the Membrane Transmitter has a two-speed keypad SW4 must be set to all “OFF” positions.

8-2.1.5. Single-Speed Modes 1-3. (The following three single-speed modes are listed for Single-Speed Membrane Transmitters only.)

Mode 1, SW4 1 turned “ON” and SW4 2 turned “OFF”. This configuration gives four-motor single-speed with up to four auxiliaries. This configuration uses the single-speed keypad with two auxiliaries labeled P1 and P2.

Mode 2, SW4 1 turned “OFF” and SW4 2 turned “ON”. This configuration gives four-motor single-speed with four auxiliaries. This configuration uses the single-speed keypad with four auxiliaries labeled Aux 1 through Aux 4.

Mode 3, SW4 1 turned “ON” and SW4 2 turned “ON”. Allows for 12 independent ON/OFF functions (relays) per transmitter button pushed.

8-2.2. To Check Data.

- 1.) For data input use “DATA” connection to RF Head
- 2.) Use “RF SW” for External Trigger input.
- 3.) Use TP2 for Ground

8-2.3. Battery Monitor Adjustment.

Connect power supply to battery leads observing polarity and set supply voltage to 5.8 volts. Adjust Battery Monitor Potentiometer R21 to just turn off red LED on the front of the transmitter.

8-2.4. Red LED Not Flashing.

If the red LED indicator on the transmitter does not flash when the transmitter is turned ON or while operating crane with the transmitter, replace the batteries they are weak. Weak batteries may operate the crane for a while, but the LED will not flash. If the battery is too low the battery monitor will shut the transmitter OFF. See [Section 5-4. Battery Replacement](#) for proper procedure.

NOTE

IF THE BATTERIES ARE INSTALLED BACKWARDS IN THE MEMBRANE TRANSMITTER THE FUSE IN THE BATTERY COMPARTMENT WILL BLOW TO PROTECT THE INTERNAL CIRCUITRY.

8-2.5. Battery Fusing.

The Membrane Transmitter is protected from reverse battery polarity and shorts by a fuse, part number F2712-1.5 (1.5 Amp, 250V, Fast Acting, 2 AG). If the batteries are installed in backwards this fuse will blow to protect the internal electronics.

Section 8 – Servicing and Transmitter Programming (Continued)

8-2.6. Repositioning of Membrane Transmitter Motion Switch Functions (for Two-Speed Membrane Transmitter only).

SW3 positions 1 through 3 can change the functional positions of the switches controlling bridge, hoist and trolley. This can be useful to align East/West and North/South. This reconfiguration does NOT affect receiver wiring. See [Figure 8-3. Membrane Transmitter M/C Module E10635](#) for switch location.

Figure 8-4. Membrane Transmitter Motion Switch Positioning.

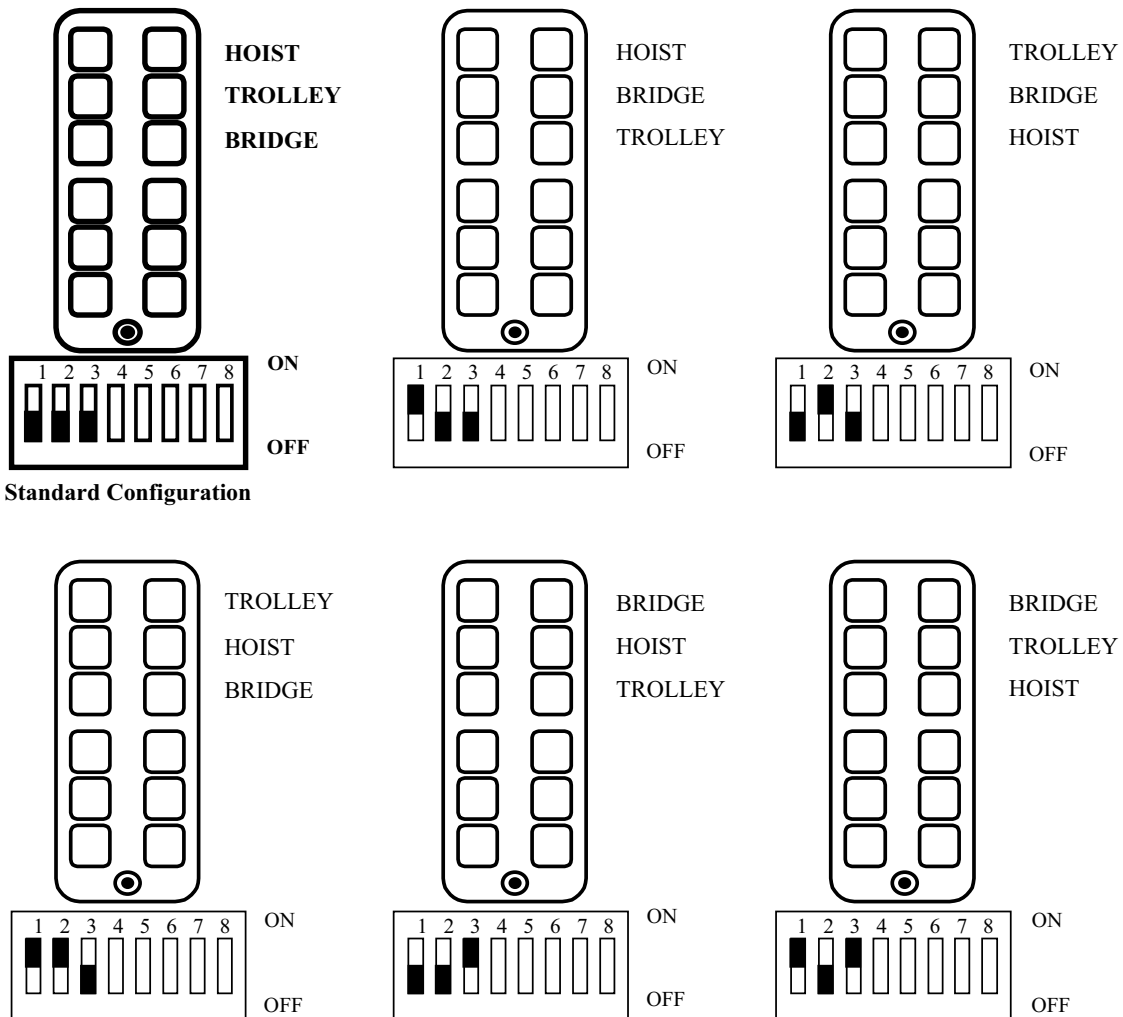

Section 8 – Servicing and Transmitter Programming (Continued)

8-3. Single-Speed Membrane Transmitter Configurations.

Normally single-speed transmitters are not provided with the 10K6/9. This section is for reference only when using a Single-Speed Membrane Transmitter. All single-speed modes require that the transmitter switch SW3 positions 1 through 3 are all set to OFF.

The EPROM's for the single-speed unit is FW2904-0T and FW2904-ON where 0T means with 15-minute-time-out-timer and 0N means no time-out-timer.

See [Figure 8-3. Membrane Transmitter M/C Module E10635](#) for location of SW3 and SW4. A single-speed keypad (part number S313-1) with special inserts (part number A9657-1) is

required for these configurations. The single-speed modes 1 through 3 do not change the outputs, but change the directional lockouts, i.e., E and W cannot be used at the same time. Mode 3 has no lockouts. As for which outputs are controlled by the single-speed transmitter, the switch positions as numbered in the Mode 3 diagram below are indicated on each of the wiring diagrams in [Section 6. Wiring](#). See [Section 6-9. Legend](#) for details. The settings shown in [Figure 6-5. 10K9, Two Receivers, Two-Speed North/South Bridge, East/West Trolley and Hoist](#) split the keypad upper and lower half between the two receivers and settings shown in [Figure 6-7. 10K9, Two Receivers, Two-Speed East/West Bridge, North/South Trolley and Hoist](#) split the keypad right and left between the two receivers.

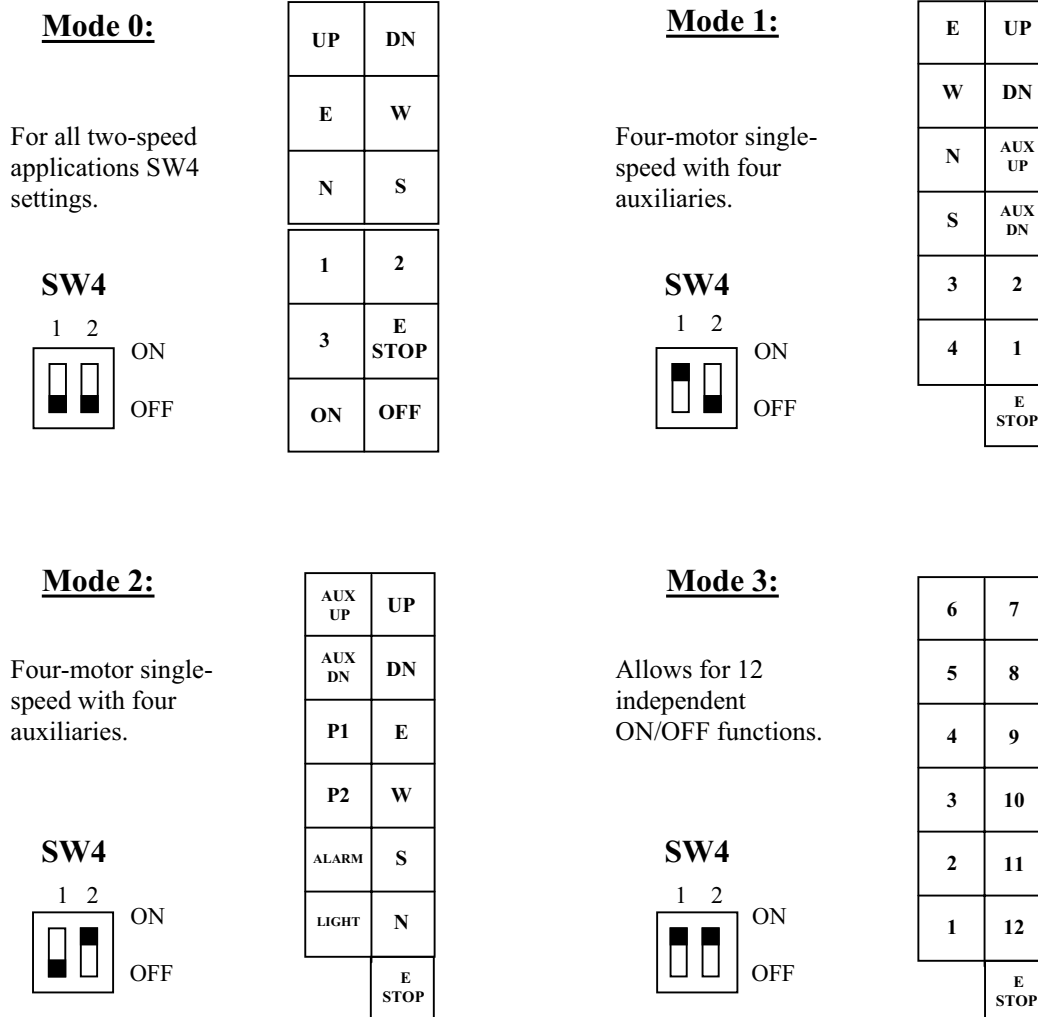

Figure 8-5. Membrane Transmitter Single-Speed Configurations.

Section 8 – Servicing and Transmitter Programming (Continued)

8-4. Pendant Transmitter Servicing and Programming.

The Single-Speed or the Two-Speed 10K12 Pendant Transmitter may be used with the 10K6/9 Receiver. The Pendant Transmitter M/C Board is shown in [Figure 8-6](#). Refer to paragraphs below for Servicing Procedures.

8-4.1. Single-Speed Pendant.

For the Single-Speed Pendant 10K12 Transmitter the only wiring configuration is the diagram in [Figure 6-9. 10K6 Single Receiver with Single-Speed Pendant, Single-Speed Bridge, Trolley and Hoist.](#)

8-4.2. Two-Speed Pendant.

For the labeling of the Pendant to functionally match the labeling of the Membrane, the Two-Speed 10K12 Pendant Transmitter must have dipswitch SW3 position 1 in the “ON” position. With SW3 set in this way the labels of the pushbuttons of the Pendant Transmitter match the directional notations on the two-speed wiring diagrams in [Section 6. Wiring.](#) Failure to turn switch SW3 position 1 to “ON” will cause EAST/WEST and NORTH/SOUTH to be exchanged respectively.

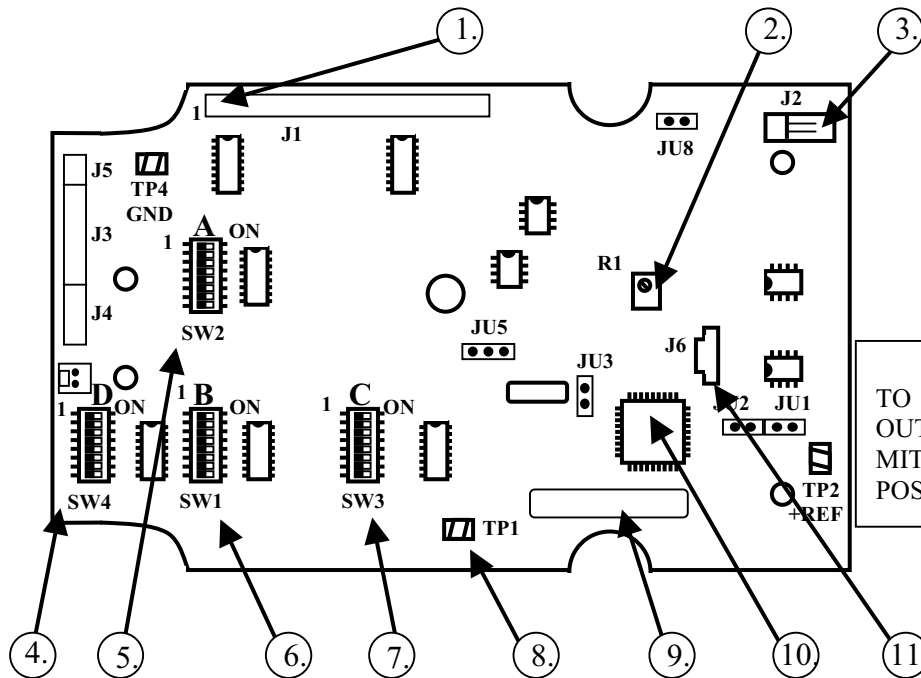

Figure 8-6.
Pendant
Transmitter M/C
Module E10636

NOTE
TO DISABLE TIME-
OUT-TIMER IN TRANS-
MITTER TURN SW3
POSITION 3 TO ON.

- | | | |
|--|--|---|
| 1.) J1 Pin 1 Data Input. | 5.) SW2 “A” Access Code Switch. | 8.) Test Point 1 External Trigger for Data. |
| 2.) Stepless Switch Level Adjustment. (Factory Set). | 6.) SW1 “B” Access Code Switch. | 9.) Software version label. |
| 3.) Battery Connector. | 7.) SW3 “C” Configuration Switch. SW3 position 8 “ON” disables Time-out-timer. | 10.) Flash ROM. |
| 4.) SW4 “D” Mode Switch. | | 11.) Flash ROM Serial Programming Port. |

Section 8 – Servicing and Transmitter Programming (Continued)

8-4.3. Pendant Transmitter Switch Settings.

SW3

Position Controls

- 1-3 Switch Positioning. See [Section 8-6.9](#).
- 5-8 Not used on 10K6/9. All positions should be set to OFF.
- 8 Time-out-timer disable, turn “ON” to disable time-out-timer.

SW4

Position Controls

- 1-2 Mode Select. See below.
- 3-8 No function for 10K6/9 system keep turned OFF.

8-4.3.1. SW3 Positions 1-3 Switch Positioning. (Standard configuration all “OFF”).

If replacing a Membrane Transmitter with a Pendant Transmitter on an existing installation or making them interchangeable and keeping the existing receiver wiring, open the Pendant Transmitter, find dipswitch SW3 and move position 1 (SW3) to “ON”. See [Figure 8-6. Pendant Transmitter M/C Module E10636](#). The Pendant Transmitters labeling and functions North and South, East and West will match the Membrane Transmitter.

NOTE

FOR THE TWO-SPEED PENDANT TRANSMITTER THE FUNCTIONAL POSITIONS OF THE VARIOUS BUTTONS CONTROLLING THE HOIST, BRIDGE AND TROLLEY CAN BE MOVED BY TRANSMITTER DIPSWITCH SW3 POSITIONS SW3-1 THROUGH SW3-3. NO CHANGE IN RECEIVER WIRING IS NEEDED TO USE THESE FUNCTIONS. SEE [SECTION 8-4.9. REPOSITIONING OF PENDANT TRANSMITTER MOTION SWITCH FUNCTIONS](#) FOR SWITCH VERSUS BUTTON CONFIGURATIONS.

8-4.3.2. Time-out-timer Disable. SW3 Position 8 (Normally keep turned “OFF”).

The transmitter has an approximate 15-minute time-out-timer. If the transmitter is not used for over 15 minutes it will shut down. This transmitter time-out-timer function is transmitter dipswitch selectable. SW3 position 8 disables the time-out-timer. Turning SW3-8 “ON” disables the time-out-timer. If disabling the transmitter

time-out-timer, remember to also replace the receiver(s) EPROM(s) to disable the time-out-timer in the receiver. See [Section 7-5. Receiver Time-out-timer for details](#).

8-4.3.3. Transmitter Programming SW4 Position 1-2 Mode Enable. (Standard Mode 1 keep 1-2 turned “OFF”).

Mode 1, SW4 1-2 all “OFF”. The 10K12 single-speed system comes standard configured this way from the factory with three motion controls and six auxiliaries (controlled by the toggle switches). The 10K12 two-speed system comes standard configured this way from the factory with three two-speed controls and three auxiliaries (controlled by the toggle switches, the rotary is non-functional).

Mode 2, SW4-1 turned “OFF” and SW4 2 turned “ON”. The 10K12 two-speed system configured this way is able to control four two-speed motion controls and no auxiliaries this give bridge, trolley, main and aux hoist. The rotary selector switch functions are H1 main hoist, H2 aux hoist and B both main and aux hoist (the toggle switches are non-functional).

Mode 3, SW4-1 and 2 turned “ON”. The 10K12 Two-Speed system will control up to 5 motors using the rotary selector switch. This mode reconfigures two of the 10K12 auxiliary outputs (Aux 1 and Aux 2) to be external motor select functions by the rotary switch. In this mode the auxiliary toggle switch Aux 1 and Aux 2 is disabled. When the rotary switch is in the H1 or H2 position Aux 1 relay or Aux 2 relay will pull in respectively when ever trolley or hoist pushbuttons are pressed. When the rotary switch is in B position both Aux 1 and Aux 2 relays will pull in.

8-4.4. To Check Data.

- 1.) For data input use pin 1 of J1.
- 2.) Use TP1 for External Trigger input.
- 3.) Use TP4 for Ground.

8-4.5. Battery Monitor Adjustment.

Battery monitor is factory preset no adjustment available.

Section 8 – Servicing and Transmitter Programming (Continued)

8-4.6. Red LED Not Flashing.

If the red LED indicator on the transmitter does not flash when the transmitter is turned ON or while operating crane with the transmitter, replace the batteries they are weak. Weak batteries may operate the crane for a while, but the LED will not flash. If the battery is too low the battery monitor will shut the transmitter OFF. See [Section 5-4. Battery Replacement](#) for proper procedure.

8-4.7. Stepless Switch Adjustment.

R1 is factory preset and controls the upper level of the stepless switch range.

8-4.8. Pendant Transmitter Software.

There is no EPROM in the Pendant Transmitter; software is stored internally in non-volatile flash memory. Software updates are done in the factory through the serial port. A software version label on the board indicates the software version loaded into flash memory.

Section 8 – Servicing and Transmitter Programming (Continued)

8-4.9. Repositioning of Pendant Transmitter Motion Switch Functions (for Two-Speed Pendant Transmitter only).

SW3 positions 1 through 3 can change the functional positions of the switches controlling bridge, hoist and trolley. This can be useful to align East/West and North/South. This reconfiguration does NOT affect receiver wiring.

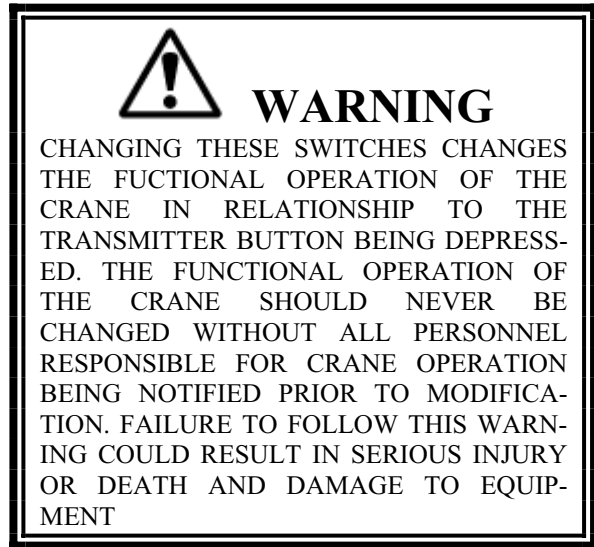
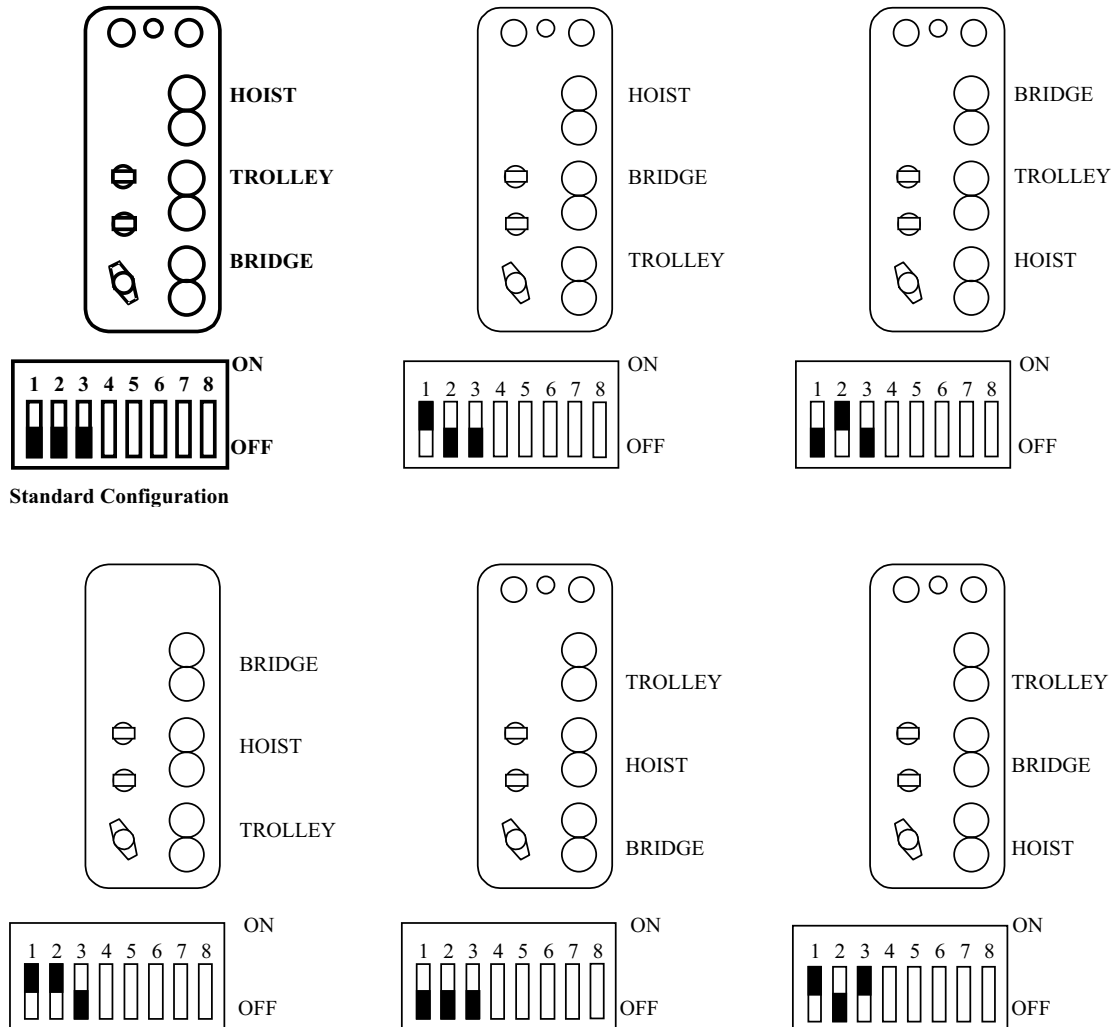

Figure 8-7. Pendant Transmitter Motion Switch Positioning.



Section 9 – Spare Parts

PART NUMBER	DESCRIPTION
RECEIVER	
F2711-2	FUSE .5 AMP, SLO BLOW 250V
FW2824-1T	RECEIVER EPROM WITH 15-MINUTE TIME-OUT-TIMER
FW2824-1N	RECEIVER EPROM WITHOUT TIME-OUT-TIMER
FW2841-0T	MULTIBOX RECEIVER EPROM WITH 15-MINUTE TIME-OUT-TIMER
10K6/ASK	SPARE PARTS KIT CONSISTING OF RECEIVER MODULE, CPU OUTPUT MODULE, AND POWER SUPPLY MODULE
E13151-X	UHF CONVERTER/RECEIVER MODULE
E10185-0	RECEIVER CPU OUTPUT MODULE
E10186-0	POWER SUPPLY MODULE
E2028-1	REMOTE ANTENNA KIT
H441-0	RF RECEIVER MODULE ASSEMBLY MOUNTING SCREWS (4) CONNECTOR PLUG IN:
TS1060-3	3 POSITION
J4655-0	6 POSITION
TS1060-8	8 POSITION (2)
CR260-0	MOV
K1304-0	RELAY (OUTPUT) (11)
S2721-8	DIPSWITCH (ACCESS CODE) (4)
H1223-0	SCREW ROUND HEAD #10-24 X 1"
MEMBRANE AND SLIDER TRANSMITTER	
F2712-1.5	FUSE 1.5 AMP, 250V FAST ACTING 2 AG
FW2836-0	TWO SPEED TACTILE MEMBRANE EPROM FOR TRANSMITTER M/C MODULE E10635
A9654-0	STRAP ASSEMBLY
FW2940-0T	SLIDER EPROM WITH 15-MINUTE TIME-OUT
FW2940-0N	SLIDER EPROM WITH NO TIME-OUT
A10662-1	TRANSMITTER CASE ASSEMBLY
E9654-0	BATTERY HOLDER ASSEMBLY
A10664-2	BATTERY DOOR ASSEMBLY
E10640-2	BEZEL ASSEMBLY (TWO-SPEED TRANSMITTER)
S22803-0	MEMBRANE SWITCH PAD (TACTILE)
MP9656-0	VINYL POUCH
A9665-0	RUBBER BOOT ASSEMBLY
AA CELL 1.5 VOLTS	BATTERY (5)
PENDANT TRANSMITTER	
E10668-11	CASE, TOP PENDANT TRANSMITTER, COMPLETE WITH SWITCHES, DECALS, BOOTS
MP10668-1	CASE ONLY, TOP PENDANT TRANSMITTER
H634-0	BOOT, GRAY (PUSHBUTTON)
H635-0	BOOT, RED (PUSHBUTTON)
H2055-3	LENS/MOUNT, LED W/SPACER, RED
S1058-0	SWITCH, PUSHBUTTON, TWO-SPEED SBRU-SD
S1026-0	SWITCH, PUSHBUTTON, MOM N/O
S1041-0	SWITCH, TOGGLE, SPDT, CTR OFF
MP10666-0	KNOB, ROTARY 1/2" DIA., BLACK
MP10661-0	BOOT, TOGGLE SW., BLACK
A10667-5	BOTTOM CASE W/O BATTERY DOOR
A10669-1	BATTERY DOOR W/FOAM, W/O SCREWS AND LATCH
MP10676-0	FOAM, BATTERY DOOR

Section 9 – Spare Parts (Continued)

PART NUMBER	DESCRIPTION
PENDANT TRANSMITTER (CONTINUED)	
MP10677-0	GASKET FOR BOTTOM CASE
H1047-0	COVER SCREWS (8)
MP1049-0	SWITCH GUARD WITH SCREWS
E10668-11LT	SAME AS E1066-11 BUT WITH SWITCH GUARD AND LARGE TOGGLES
MP10668-3	CASE TOP ONLY, LARGE TOGGLES
S605-0	SWITCH, TOGGLE SPDT CENTER OFF, LARGE
A1011-X	BOOTS (6) (SEE *NOTE 1 BELOW FOR THE PROPER SUFFIX)
MP10650-1	LATCH FOR BATTERY DOOR
S605-0	SWITCH, TOGGLE SPDT CENTER OFF, LARGE
A1011-X	BOOTS (6) (SEE *NOTE 1 BELOW FOR THE PROPER SUFFIX)
H251-0	SCREW FOR BATTERY DOOR LATCH
H252-0	WAVE WASHER FOR BATTERY DOOR LATCH
H2034-0	FLAT WASHER FOR BATTERY DOOR LATCH
N13653-2	FCC LABEL
E10688-0	BATTERY HOLDER ASSEMBLY, W/CABLE
MP10680-0	O'RING
MP10678-0	SHOULDER STRAP
BT10KP-0	BATTERY, ALKALINE
BT10KP-1	BATTERY, NICAD
E10670-1	BATTERY CHARGER
A10669-1	BATTERY DOOR

*NOTE 1	<u>UP</u>	<u>DOWN</u>	<u>EAST</u>	<u>WEST</u>	<u>NORTH</u>	<u>SOUTH</u>
YELLOW	23	24	31	32	29	30
BLACK	3	4	11	12	9	10

Section 9 – Spare Parts (Continued)

This page intentionally left blank.