

IMPULSE[®]G+ & VG+ *Series 4*

Adjustable Frequency/Vector Crane Controls

EtherNet/IP Installation Manual



MAGNETEK
MATERIAL HANDLING

April 2015
Part Number: 144-23924 R2
© Copyright 2015 Magnetek

1. Preface and Safety

Magnetek manufactures products used as components in a wide variety of industrial systems and equipment. The selection and application of Magnetek products remain the responsibility of the equipment manufacturer or end user. Magnetek accepts no responsibility for the way its products are incorporated into the final system design. Under no circumstances should any Magnetek product be incorporated into any product or design as the exclusive or sole safety control. Without exception, all controls should be designed to detect faults dynamically and fail safely under all circumstances. All systems or equipment designed to incorporate a product manufactured by Magnetek must be supplied to the end user with appropriate warnings and instructions as to the safe use and operation of that part. Any warnings provided by Magnetek must be promptly provided to the end user. Magnetek offers an express warranty only as to the quality of its products in conforming to standards and specifications published in the Magnetek manual. **NO OTHER WARRANTY, EXPRESS OR IMPLIED, IS OFFERED.** Magnetek assumes no liability for any personal injury, property damage, losses, or claims arising from misapplication of its products.

Applicable Documentation

The following manuals are available for the SI-EN3 option:

Option

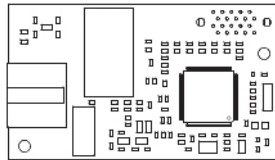

**IMPULSE®G+/VG+ Series 4
Option SI-EN3 EtherNet/IP
Installation Manual
Manual No: 144-23924**

Read this manual first. The installation manual is packaged with the option and contains detailed information about the option, information required to install the option and set up related drive parameters.

IMPULSE®G+/VG+ Series 4 Drive

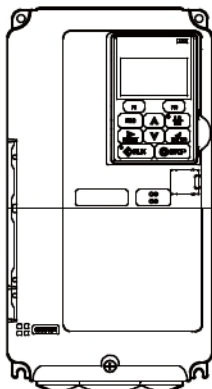

**IMPULSE®G+/VG+ Series 4
Quick Start Guide**

The drive manuals cover basic installation, wiring, operation procedures, functions, troubleshooting, and maintenance information. The manuals also include important information about parameter settings and drive tuning.

**IMPULSE®G+/VG+ Series 4
Instruction Manual**

Access <http://www.magnetek.com> to obtain Magnetek instruction manuals.

Terms

Drive: IMPULSE®•G+/VG+ Series 4

Option: IMPULSE®•G+/VG+ Series 4 SI-EN3 EtherNet/IP option

Registered Trademarks

- EtherNet/IP is a trademark of the ODVA.
- All trademarks are the property of their respective owners.

Supplemental Safety Instructions

Read and understand this manual before installing, operating, or servicing this option. The option must be installed according to this manual and local codes.

The following conventions are used to indicate safety messages in this manual. Failure to heed these messages could result in serious or possibly even fatal injury or damage to the products or to related equipment and systems.



DANGER

DANGER indicates an imminently hazardous situation which, if not avoided, will result in death or serious injury. This signal word is to be limited to the most extreme situations.



WARNING

WARNING indicates a potentially hazardous situation which, if not avoided, could result in death or serious injury.



CAUTION

CAUTION indicates a potentially hazardous situation which, if not avoided, could result in minor or moderate injury. It may also be used to alert against unsafe practices.

NOTICE

NOTICE indicates an equipment damage message.

NOTE: A *NOTE* statement is used to notify installation, operation, programming, or maintenance information that is important, but not hazard-related.

General Safety

General Precautions

- The diagrams in this section may include options and drives without covers or safety shields to illustrate details. Reinstall covers or shields before operating any devices. The option should be used according to the instructions described in this manual.
- Any illustrations, photographs, or examples used in this manual are provided as examples only and may not apply to all products to which this manual is applicable.
- The products and specifications described in this manual or the content and presentation of the manual may be changed without notice to improve the product and/or the manual.
- When ordering new copies of the manual, contact your Magnetek representative and provide the manual number shown on the front cover.



DANGER

Heed the safety messages in this manual.
Failure to comply will result in death or serious injury.

The operating company is responsible for any injuries or equipment damage resulting from failure to heed the warnings in this manual.

NOTICE

Do not expose the drive to halogen group disinfectants.
Failure to comply may cause damage to the electrical components in the option.

Do not pack the drive in wooden materials that have been fumigated or sterilized.

Do not sterilize the entire package after the product is packed.

Do not modify the drive or option circuitry.
Failure to comply could result in damage to the drive or option and will void warranty.

Magnetek is not responsible for any modification of the product made by the user. This product must not be modified.

2. Product Overview

About This Product

The SI-EN3 (option) is designed for the IMPULSE®•G+/VG+ Series 4 drives, which provides a communications connection between the drive and an ODVA EtherNet/IP network. The option connects the drive to an EtherNet/IP network and facilitates the exchange of data.

This manual explains the handling, installation and specifications of this product.

EtherNet/IP is a communications link to connect industrial devices (such as smart motor controllers, operator interfaces, and variable frequency drives) as well as control devices (such as programmable controllers and computers) to a network. EtherNet/IP is a simple networking solution that reduces the cost and time to wire and install factory automation devices, while providing interchangeability of like components from multiple vendors.

EtherNet/IP is an open device network standard.

By installing the option to a drive, it is possible to do the following from an EtherNet/IP master device:

- operate the drive
- monitor the operation status of the drive
- change parameter settings.







3. Receiving

Please perform the following tasks upon receiving the option:

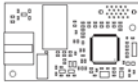
- Inspect the option for damage. Contact the shipper immediately if the option appears damaged upon receipt.
- Verify receipt of the correct model by checking the model number printed on the option nameplate (refer to Figure 1 on page 7 for more information).
- Contact your supplier if you have received the wrong model or the option does not function properly.

Option Package Contents

Description:	Option	Ground Wire	Screws (M3)	LED Label	Installation Manual
--					
Quantity	1	1	3	1	1

Tools Required for Installation

- A Phillips screwdriver (M3 metric/#1, #2 U.S. standard size*) is required to install the option and remove drive front covers.
- Diagonal cutting pliers (required for some drive models).
- A small file or medium grit sandpaper (required for certain drive models).

*Screw sizes vary by drive capacity. Select a screwdriver appropriate for the drive capacity.

NOTE: Tools required to prepare option cables for wiring are not listed in this manual.

4. Option Components

SI-EN3 EtherNet/IP Option

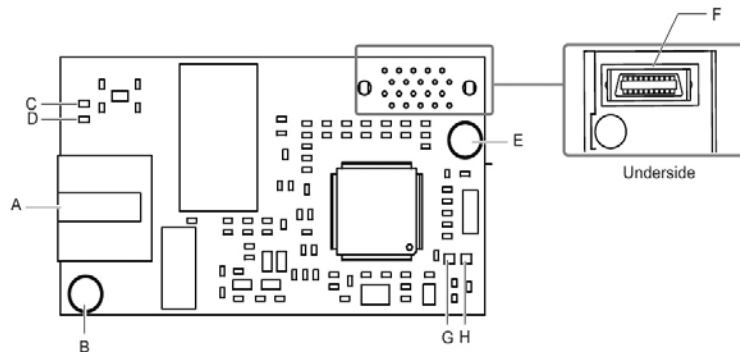

- A – EtherNet/IP Modular Female Connector (CN1)
- B – Ground Terminal and installation hole <1>
- C – LED (10/100) <2>
- D – LED (LINK/ACT) <2>
- E – Installation hole
- F – Connector (CN5-A)
- G – LED (NS) <2>
- H – LED (MS) <2>

<1> The ground wire provided in the option shipping package must be connected during installation.

<2> Refer to Option LED Display on page 1-8 for details on the LEDs.

Figure 1: Option (Top View)

Terminal CN1

The communication connector on the option is a modular RJ45 female connector designated CN1. CN1 is the connection point for a customer supplied male Ethernet network cable.

Table 1: Male 8-Way Ethernet Modular Connector (Customer Supplied)

Male Ethernet 8-Way Modular Connection	Pair	Description
1	(Pair 2)	Transmit data (TXD) +
2	(Pair 2)	Transmit data (TXD) -
3	(Pair 3)	Receive data (RXD) +
4	(Pair 1)	Not used <1>
5	(Pair 1)	Not used <1>
6	(Pair 3)	Receive data (RXD) -
7	(Pair 4)	Not used <1>
8	(Pair 4)	Not used <1>

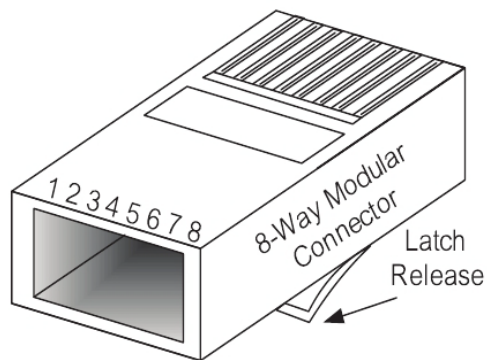

<1> Not used for 10 Mbps and 100 Mbps networks.

Option LED Display

The option has four LEDs:

Bi-color Status LEDs:

- Module status (MS) red/green
- Network status (NS) red/green

Green Ethernet LEDs:

- Network speed-10/100 (MS) green
- Link status and network activity-Link/Act (NS) red/green

The operational states of the option LEDs after the power-up diagnostic LED sequence is completed are described in Table 5 on page 15. Wait at least 2 seconds for the power-up diagnostic process to complete before verifying the states of the LEDs.

Table 2: Option LED States

Name	Indication		Operating Status	Remarks
	Color	Status		
MS (visible through drive cover)	--	OFF	Power supply OFF	Power is not being supplied to the drive
	Green	ON	Option operating	The option is operating normally
	Green	Flashing	Option initializing	The option is configuring an IP address
	Red	ON	Fatal error occurred	The option has detected a fatal (unrecoverable) error
	Red	Flashing	Non-fatal error occurred	The option has detected a non-fatal (recoverable) error
	Green/Red	Flashing	Option self-test	The option is in self-test mode
NS (visible through drive cover)	--	OFF	Offline or Power supply OFF	--
	Green	ON	Online communications established	The option is online and has established connections
	Green	Flashing	Online communications not established	The option is online without an established connection
	Red	ON	Communications error (fatal)	The option detected a duplicate IP address
	Red	Flashing	Communications time-out (non-fatal)	A communications time-out occurred
	Green/Red	Flashing	Option self-test	The option is in self-test mode

Table 3: Option LEDs

Name	Indication		Operating Status
	Color	Status	
10/100 (visible with front cover removed)	Green	OFF	10 Mbps is established
	Green	ON	100 Mbps is established
LINK/ACT (visible with front cover removed)	Green	OFF	Link is not established
	Green	ON	Link is established
	Green	Flashing	Link is established and there is network activity

Power-Up Diagnostics

An LED test is performed each time the drive is powered up. The initial boot sequence may take several seconds. After the LEDs have completed the diagnostic LED sequence, the option is successfully initialized. The LEDs then assume operational conditions as shown in Table 2 on page 8.

Table 4: Power-Up Diagnostic LED Sequence

Sequence	Module Status (MS)	Network Status (NS)	Time (ms)
1	Green	OFF	250
2	Red	OFF	250
3	Green	OFF	--
4	Green	Green	250
5	Green	Red	250
6	Green	OFF	--

5. Installation Procedure

Section Safety



DANGER

Electric Shock Hazard

Do not connect or disconnect wiring while the power is on.

Failure to comply will result in death or serious injury.

Disconnect all power to the drive, wait at least five minutes after all indicators are off, measure the DC bus voltage to confirm safe level, and check for unsafe voltages before servicing to prevent electric shock. The internal capacitor remains charged even after the power supply is turned off. The charge indicator LED will extinguish when the DC bus voltage is below 50 VDC.



WARNING

Electrical Shock Hazard

Do not remove the front cover of the drive while the power is on.

Failure to comply could result in death or serious injury.

The diagrams in this section may include options and drives without covers or safety shields to show details. Be sure to reinstall covers or shields before operating any devices. The option board should be used according to the instructions described in this manual.

Do not allow unqualified personnel to use equipment.

Failure to comply could result in death or serious injury.

Maintenance, inspection, and replacement of parts must be performed only by authorized personnel familiar with installation, adjustment, and maintenance of this product.

Do not touch circuit boards while the power to the drive is on.

Failure to comply could result in death or serious injury.

Do not use damaged wires, place excessive stress on wiring, or damage the wire insulation.

Failure to comply could result in death or serious injury.

Fire Hazard

Tighten all terminal screws to the specified tightening torque.

Loose electrical connections could result in death or serious injury by fire due to overheating of electrical connections.

NOTICE

Damage to Equipment

Observe proper electrostatic discharge (ESD) procedures when handling the option, drive, and circuit boards.

Failure to comply may result in ESD damage to circuitry.

Never shut the power off while the drive is outputting voltage.

Failure to comply may cause the application to operate incorrectly or damage the drive.

Do not operate damaged equipment.

Failure to comply may cause further damage to the equipment.

Do not connect or operate any equipment with visible damage or missing parts.

Do not use unshielded cable for control wiring.

Failure to comply may cause electrical interference resulting in poor system performance.

Use shielded twisted-pair wires and ground the shield to the ground terminal of the drive.

Properly connect all pins and connectors.

Failure to comply may prevent proper operation and possibly damage equipment.

Check wiring to ensure that all connections are correct after installing the option and connecting any other devices.

Failure to comply may result in damage to the option.

Prior to Installing the Option

Prior to installing the option, wire the drive, make necessary connections to the drive terminals, and verify that the drive functions normally without the option installed. Refer to the Quick Start Guide packaged with the drive for information on wiring and connecting the drive.

Figure 2 shows an exploded view of the drive with the option and related components for reference.

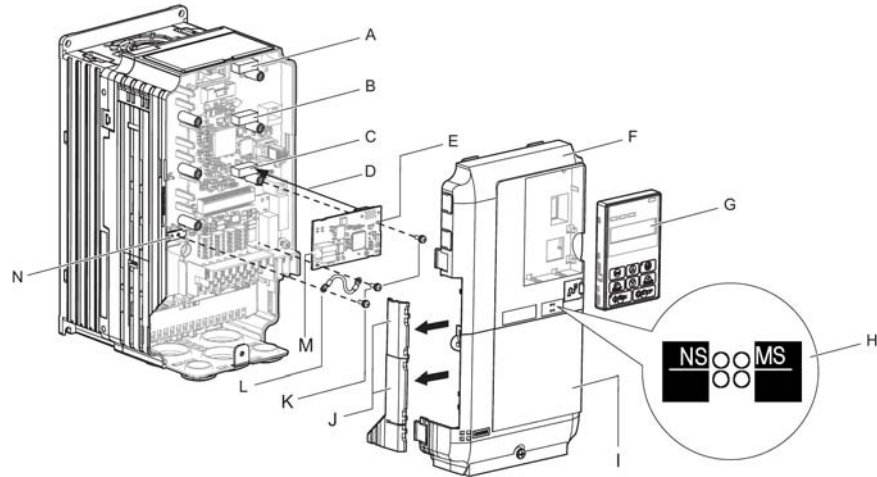

- | | |
|---------------------------------------|-------------------------------------|
| A – Connector CN5-C | H – LED label |
| B – Connector CN5-B | I – Drive terminal cover |
| C – Connector CN5-A | J – Removable tabs for wire routing |
| D – Insertion point for CN5 connector | K – Included screws |
| E – SI-EN3 option | L – Ground wire |
| F – Drive front cover | M – Option modular connector CN1 |
| G – Digital operator | N – Drive grounding terminal (FE) |

Figure 2: Drive Components with Option

Installing the Option

Remove the front covers of the drive before installing the option. Refer to the drive Quick Start Guide for directions on removing the front covers. Cover removal varies depending on drive size. This option can be inserted only into the CN5-A connector located on the drive control board.

1. Shut off power to the drive, wait the appropriate amount of time for voltage to dissipate, then remove the digital operator (G) and front covers (F, I). Front cover removal varies by model. Refer to the Quick Start Guide supplied with the drive for more information on front cover removal.



DANGER

Electrical Shock Hazard.

Do not connect or disconnect wiring while the power is on. Failure to comply will result in death or serious injury. Before installing the option, disconnect all power to the drive. The internal capacitor remains charged even after the power supply is turned off. The charge indicator LED will extinguish when the DC bus voltage is below 50 VDC. To prevent electric shock, wait at least five minutes after all indicators are off and measure the DC bus voltage level to confirm safe level.

NOTICE

Damage to Equipment

Observe proper electrostatic discharge procedures (ESD) when handling the option, drive, and circuit boards. Failure to comply may result in ESD damage to circuitry.

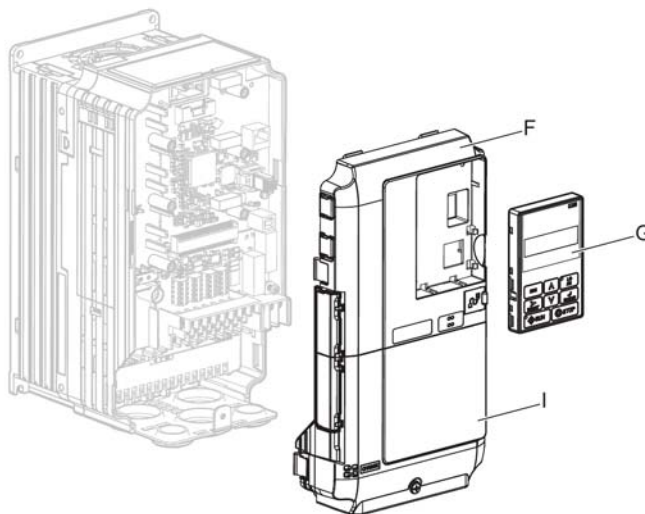

Figure 3: Remove the Front Covers and Digital Operator

2. With the front covers and digital operator removed, apply the LED label (H) in the appropriate position on the drive top front cover (F).

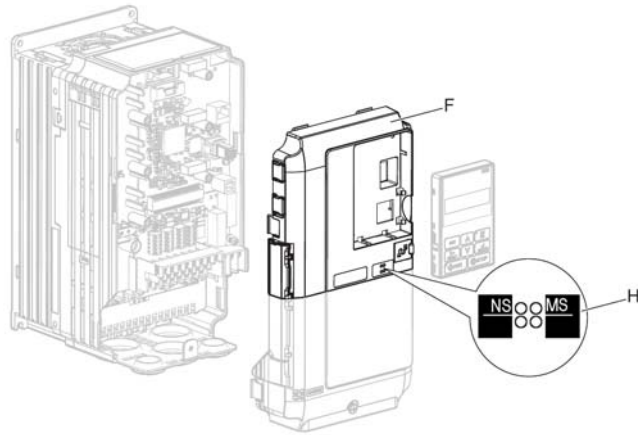

Figure 4: Apply the LED Label

3. Insert the option (E) into the CN5-A connector (C) located on the drive and fasten it using one of the included screws (K).

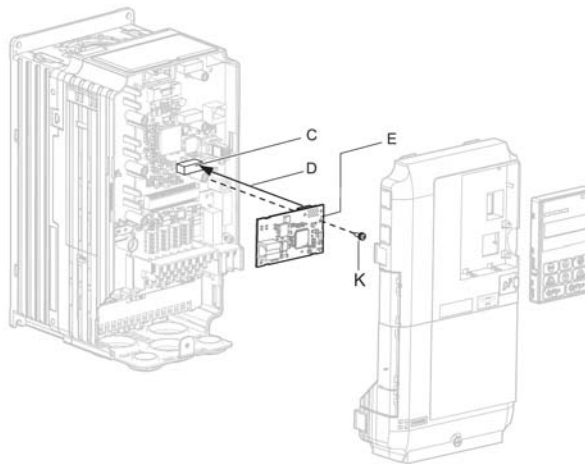

Figure 5: Insert the Option

4. Connect the ground wire (L) to the ground terminal (N) using one of the remaining provided screws (K). Connect the other end of the ground wire (L) to the remaining ground terminal and installation hole on the option (E) using the last remaining provided screw (K) and tighten both screws to 0.5 ~ 0.6 nm or (4.4 ~ 5.3 in-lbs).

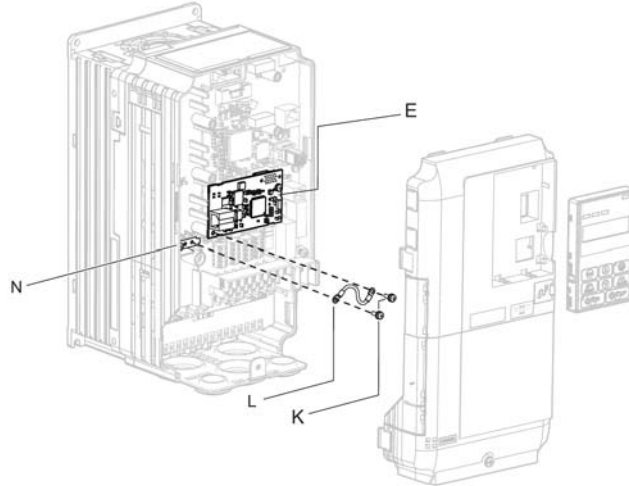

Figure 6: Connect the Ground Wire

NOTE: There are two screw holes on the drive for use as ground terminals. When connecting three options, two ground wires will need to share the same drive ground terminal.

Routing

5. Ethernet cable routing is dependent on drive model and may require routing the wiring through the side of the front cover to the outside to provide adequate space for the wiring. In these cases, using diagonal cutting pliers, cut out the perforated openings on the left side of the drive front cover. Sharp edges along the cut out should be smoothed down with a file or sand paper to prevent any damage to the wires.

5.a Route the Ethernet cable inside the enclosure for drives that do not require routing through the front cover. Refer to Table 5 and Figure 7 to determine the proper wire routing by drive model.

Table 5: Model-Specific Cable Routing

Drive Series	Model	Wire Routing <1>	
		Through Front Cover	Inside Drive
Series 4	G+/VG+S4-5001 to 5009	Figure 7(A)	--
Series 4	G+/VG+S4-5017 and above	--	Figure 7(B)

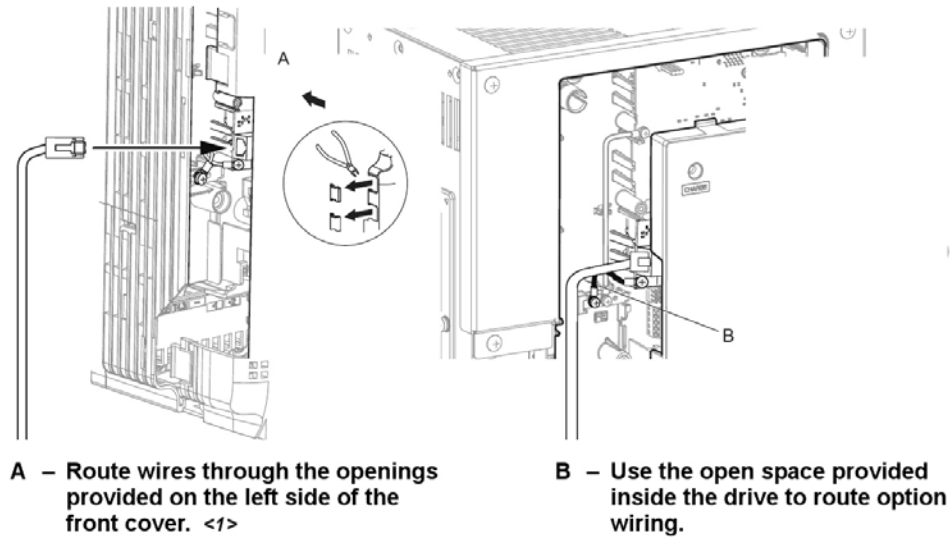

<1> The drive will not meet NEMA Type 1 requirements if wiring is exposed outside the enclosure.

Figure 7: Wire Routing Examples

6. Connect the Ethernet communication cable to the option modular connector (CN1). To connect the option to a network, insert the RJ45 connector of the CAT5e patch cable into the option modular connector (CN1). Ensure the cable end is firmly connected (see Figure 7).

IGMP Snooping

Switches implementing IGMP Snooping are strongly recommended. When IGMP Snooping is used, devices will only receive the multicast packets in which they are interested.

Communication Cable Specifications

Only use cable recommended for EtherNet/Industrial Protocol (EtherNet/IP™). Using a cable not specifically recommended may cause the option or drive to malfunction. Refer to the ODVA website for more information on network cabling (<http://www.odva.org>).

Connection Diagram

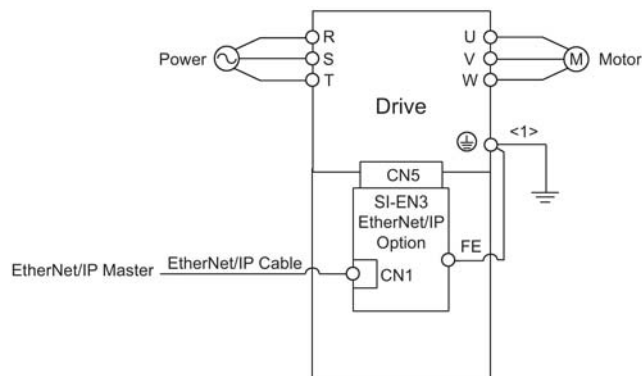

<1> The ground wire provided in the option shipping package must be connected during installation.

Figure 8: Wiring Diagram

7. Replace and secure the front covers of the drive (F, I) and replace the digital operator (G).

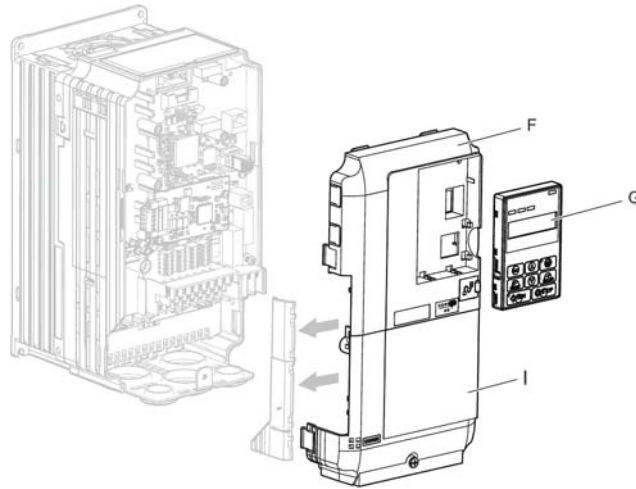

Figure 9: Replace the Front Covers and Digital Operator

NOTE: Take proper precautions when wiring the option so that the front covers will easily fit back onto the drive. Make sure no cables are pinched between the front covers and the drive when replacing the covers.

8. Set drive parameters in Table 6 on page 18 for proper option performance.

EDS Files

For network implementation of drives equipped with the option, an EDS file(s) to other industrial controls can be obtained from <http://www.magnetek.com/downloads.htm>.

6. Option Related Drive Parameters

The following parameters are used to set up the drive for operation with the option. Parameter setting instructions can be found in the IMPULSE®•G+/VG+ Series 4 Instruction Manual.

Confirm proper setting of all parameters in Table 6 before starting network communications.

Table 6: Related Parameter Settings

Parameter	Display	Function	Range	Default
B03-01	Ref Source 1	Source from where the frequency reference is generated.	0-4	1
	0 Operator	Digital operator (Keypad).		
	1 Terminals	Control circuit terminal		
	2 Serial Com	Serial communication (Port CN5-A).		
	3 Option PCB	Optional card (Port CN5-A, CN5-B or CN5-C).		
4 Pulse Input	Pulse input via Terminal RP (H06-01).			
B03-02	Run Source 1	Source from where the RUN command is generated.	0-3	1
	0 Operator	Digital operator (Keypad).		
	1 Terminals	Control circuit terminal.		
	2 Serial Com	Serial communication (Port CN5-A).		
3 Option PCB	Optional card (Port CN5-A, CN5-B or CN5-C).			
F06-01	Com Bus Flt Sel	Stopping method at communication error.	0-4	1
	0 Decel to Stop			
	1 Coast to Stop			
	2 Fast-Stop			
	3 Use B3-03 Method			
4 Alarm only				
F06-02	EF0 Detection	Option External Fault	0, 1	0
	0 Always Detected			
1 Only During Run				
F06-03	EF0 Fault Action	Option External Fault	0-4	1
	0 Decel to Stop			
	1 Coast to Stop			
	2 Fast-Stop			
	3 Use B3-03 Method			
4 Alarm Only				
F06-06	Torq Ref/Lmt Sel	Torque Reference Limit Selection	0, 1	0
	0 Disabled			
1 Enabled				

Parameter	Display	Function	Range	Default
F06-07	Fref PrioritySel	Selects how multi-step speed inputs are treated when the NetRef command is set.	0, 1	0
	0 <i>Net/Com Ref</i>	Multi-step reference disabled		
	1 <i>MultiStep Speed</i>	Multi-step reference enabled		
F06-08	Com Prm Init Sel	Determines whether communication-related parameters (F06-XX and F07-XX) are reset when the drive is initialized using A01-05	0, 1	0
	0 <i>Init Com Prms</i>	Communication-related parameters (F06-XX and F07-XX) are not reset when the drive is initialized using A01-05.		
	1 <i>No Init Com Prms</i>	Reset all communication-related parameters (F06-XX and F07-XX) when the drive is initialized using A01-05.		
F07-01	IP Address 1	IP Address 1	0–255	192
F07-02	IP Address 2	IP Address 2	0–255	168
F07-03	IP Address 3	IP Address 3	0–255	1
F07-04	IP Address 4	IP Address 4	0–255	20
F07-05	Subnet Mask 1	Subnet Mask 1	0–255	255
F07-06	Subnet Mask 2	Subnet Mask 2	0–255	255
F07-07	Subnet Mask 3	Subnet Mask 3	0–255	255
F07-08	Subnet Mask 4	Subnet Mask 4	0–255	0
F07-09	Gateway IP Add 1	Gateway Address 1	0–255	192
F07-10	Gateway IP Add 2	Gateway Address 2	0–255	168
F07-11	Gateway IP Add 3	Gateway Address 3	0–255	1
F07-12	Gateway IP Add 4	Gateway Address 4	0–255	1
F07-13	IP Add Mode Sel	Address Startup Mode	0–2	2
F07-14	Duplex Select	Duplex Mode Setting	0–2	1
F07-15	Baud Rate	Speed Mode Setting	10 or 100 mbps	10
F07-16	CommLoss Tout	Timeout Value	0–300 deciseconds	0
F07-23 to F07-32	Dynamic Output Assembly Parameters	Parameters used in Output Assembly 116. Each parameter contains a MEMOBUS/Modbus address. The value received for Output Assembly 116 will be written to this corresponding MEMOBUS/Modbus address. A MEMOBUS/Modbus address value of 0 means that the value received for Output Assembly 116 will not be written to any MEMOBUS/Modbus register.	--	0
F07-33 to F07-42	Dynamic Input Assembly Parameters	Parameters used in Input Assembly 166. Each parameter contains a MEMOBUS/Modbus address. The value sent for Input Assembly 166 will be read from this corresponding MEMOBUS/Modbus address. A MEMOBUS/Modbus address value of 0 means that the value sent for Input Assembly 166 is not defined by the user, therefore the option default register value will be returned.	--	0

Table 7: Option Monitors

Parameter	Display	Description	Value Range
U06-80 to U06-83	Online IP Address	SI-EP3 IP Address, U06-80 is the most significant octet.	0–255
U06-84 to U06-87	Online Subnet	Subnet, U06-84 is the most significant octet.	0–255
U06-88 to U06-91	Online Gateway	Gateway, U06-88 is the most significant octet.	0–255
U06-92	Online Speed	Port 1 Link Speed	10, 100
U06-93	Online Duplex	Port 1 Duplex Setting	0: Half; 1: Full
U06-94	Online Duplex	Port 2 Link Speed	0: Half; 1: Full
U06-95	Online Duplex	Port 2 Duplex Setting	0: Half; 1: Full
U06-98	First Fault	First Option Board Fault	--
U06-99	Current Fault	Current Option Board Fault	--

7. Configuring Messaging

This section provides information on methods used to control the drive with an option installed.

Drive Polled Configuration with SI-EN3

The assemblies in Table 8 are available for polled I/O:

Table 8: Supported Polled I/O Assemblies

Assembly Number (decimal)	Description	Type	Bytes	Page
21	Extended Speed Control Output	Output	4	22
23	Extended Speed and Torque Control Output	Output	6	23
71	Extended Speed Control Input	Input	4	30
73	Extended Speed and Torque Control Input	Input	6	31
100	MEMOBUS/Modbus Message Output	Output	5	24
101	Speed/Torque Control Output	Output	8	25
116	High Speed/Torque Control Output	Output	44	27
150	MEMOBUS/Modbus Message Input	Input	5	32
151	Speed/Torque Status Input	Input	8	34
166	High Speed/Torque Status Input	Input	44	36

8. Output Assemblies (Drive Consumes)

NOTE: The convention in this manual is from the PLC perspective. As such, an assembly is called an "Output Assembly" when outputted from the PLC and received by this node. This section details "Output Assemblies" that are "Consumed" by this drive.

Extended Speed Control Output - 21 (0x15)

Output Instance	Byte	Bit 7	Bit 6	Bit 5	Bit 4	Bit 3	Bit 2	Bit 1	Bit 0
21	0	--	NetRef	NetCtrl	--	--	Fault Reset	REV Run	FWD Run
	1	--							
	2	Speed Reference (Low Byte)							
	3	Speed Reference (High Byte)							

Name	Description
FWD Run	Forward Run Command (Terminal S1) 0: Stop 1: Forward Run
REV Run	Reverse Run Command (Terminal S2) 0: Stop 1: Reverse Run
Fault Reset	Fault Reset (0 to 1 transition: Fault Reset)
NetCtrl	Run command from Network 0: Depends on B03-02 1: Enables the run command from network
NetRef	Speed reference from Network 0: Depends on B03-01 1: Enables the speed reference from network
Speed Reference	Speed Command Sets drive speed reference. Speed reference data: Frequency reference/ 2^{SS} (SS: Speed scale) Setting range: 0 to 0xFFFF For example, when setting a reference of 4096 with a speed scale of 2: Speed reference data = $4096/2^2 = 1024 = 0x0400$ Unit depends on O01-03.

Extended Speed and Torque Control Output - 23 (0x17)

Output Instance	Byte	Bit 7	Bit 6	Bit 5	Bit 4	Bit 3	Bit 2	Bit 1	Bit 0
23	0	--	NetRef	NetCtrl	--	--	Fault Reset	REV Run	FWD Run
	1	--							
	2	Speed Reference (Low Byte)							
	3	Speed Reference (High Byte)							
	4	Torque Reference/Torque Limit (Low Byte)							
	5	Torque Reference/Torque Limit (High Byte)							

Name	Description
FWD Run	Forward Run Command (Terminal S1) 0: Stop 1: Forward Run
REV Run	Reverse Run Command (Terminal S2) 0: Stop 1: Reverse Run
Fault Reset	Fault Reset (0 to 1 transition: Fault Reset)
NetCtrl	Run command from Network 0: Depends on B03-02 1: Enables the run command from network
NetRef	Speed reference from Network 0: Depends on B03-01 1: Enables the speed reference from network
Speed Reference	Speed Command Sets drive speed reference. Speed reference data: Frequency reference/ 2^{SS} (SS: Speed scale) Setting range: 0 to 0xFFFF For example, when setting a reference of 4096 with a speed scale of 2: Speed reference data = $4096/2^2 = 1024 = 0x0400$ Unit depends on O01-03.
Torque Reference/ Torque Limit	Torque Reference/Torque Limit Sets the Torque Reference/Torque Limit in units of 0.1%. Sets the Torque Reference when using Torque Control (D05-01 = 0). Sets the Torque Limit when using Speed Control (D05-01 = 1). The Torque Reference and Torque Limit are disabled with F06-06 = 0.

MEMOBUS/Modbus Message Output - 100 (0x64)

Output Instance	Byte	Bit 7	Bit 6	Bit 5	Bit 4	Bit 3	Bit 2	Bit 1	Bit 0
100	0	Function Code							
	1	Register Number (High Byte)							
	2	Register Number (Low Byte)							
	3	Register Data (High Byte)							
	4	Register Data (Low Byte)							

Name	Description
Function Code	MEMOBUS/Modbus Function Code
Register Number	MEMOBUS/Modbus Register Number
Register Data	MEMOBUS/Modbus Register Data

Function Code	MEMOBUS/Modbus Function
0x00	No Operation
0x03	Read Register
0x10	Write Register

Speed/Torque Control Output - 101 (0x65)

Output Instance	Byte	Bit 7	Bit 6	Bit 5	Bit 4	Bit 3	Bit 2	Bit 1	Bit 0
101	0	S8	S7	S6	S5	S4	S3	Run Rev	Run Fwd
	1	M5-M6 Digital Output	M2-M3 Digital Output	M0-M1 Digital Output	--	--	--	Fault Reset	External Fault
	2	Speed Reference (Low Byte)							
	3	Speed Reference (High Byte)							
	4	Torque Reference/Torque Limit (Low Byte)							
	5	Torque Reference/Torque Limit (High Byte)							
	6	Torque Compensation (Low Byte)							
	7	Torque Compensation (High Byte)							

Output Instance	Byte
FWD Run	Forward Run Command (Terminal S1) 0: Stop 1: Forward Run
REV Run	Reverse Run Command (Terminal S2) 0: Stop 1: Reverse Run
S3	Terminal S3 Function Input 0: Terminal S3 Function (H01-03) OFF 1: Terminal S3 Function (H01-03) ON
S4	Terminal S4 Function Input 0: Terminal S4 Function (H01-04) OFF 1: Terminal S4 Function (H01-04) ON
S5	Terminal S5 Function Input 0: Terminal S5 Function (H01-05) OFF 1: Terminal S5 Function (H01-05) ON
S6	Terminal S6 Function Input 0: Terminal S6 Function (H01-06) OFF 1: Terminal S6 Function (H01-06) ON
S7	Terminal S7 Function Input 0: Terminal S7 Function (H01-07) OFF 1: Terminal S7 Function (H01-07) ON
S8	Terminal S8 Function Input 0: Terminal S8 Function (H01-08) OFF 1: Terminal S8 Function (H01-08) ON
External Fault	External Fault EF0 0: No External Fault (EF0) 1: External Fault (EF0)
Fault Reset	Fault Reset 0: No Fault Reset 1: Fault Reset

Output Instance	Byte
M0-M1 Digital Output	Terminal M0-M1 0: M0-M1 Open 1: M0-M1 Closed This function is programmed by H02-01.
M2-M3 Digital Output	Terminal M2-M3 0: M2-M3 Open 1: M2-M3 Closed This function is programmed by H02-02.
M5-M6 Digital Output	Terminal M5-M6 0: M5-M6 Open 1: M5-M6 Closed This function is programmed by H02-03.
Speed Reference	Speed Command Sets drive speed reference. Unit depends on O01-03. Unit is not affected by Speed Scale SS.
Torque Reference/ Torque Limit	Torque Reference/Torque Limit Sets the Torque Reference/Torque Limit in units of 0.1%. Sets the Torque Reference when using Torque Control (D05-01 = 0). Sets the Torque Limit when using Speed Control (D05-01 = 1). The Torque Reference and Torque Limit are disabled with F06-06 = 0.
Torque Compensation	Sets the amount of Torque Compensation Sets in units of 0.1%.

High Speed/Torque Control Output - 116 (0x74)

This assembly is dynamic and can be configured as to what parameters are used. The following 20 Bytes (0-19) are fixed. If an error occurs while trying to write to the dynamic parameters, the appropriate error bit in Assembly 166 will be set. If more information is needed as to the nature of the error, the extended error status can be read explicitly through Class 0xA6, Instance 1, Attribute 0x64. This will return 20 Bytes with each dynamic parameter in Assembly 116 having a Byte dedicated to its extended error status.

Output Instance	Byte	Bit 7	Bit 6	Bit 5	Bit 4	Bit 3	Bit 2	Bit 1	Bit 0	
116	0	S8	S7	S6	S5	S4	S3	REV Run	FWD Run	
	1	M5-M6 Digital Output	M2-M3 Digital Output	M0-M1 Digital Output	--	--	--	Fault Reset	External Fault	
	2	Speed Reference (Low Byte)								
	3	Speed Reference (High Byte)								
	4	Torque Reference/Torque Limit (Low Byte)								
	5	Torque Reference/Torque Limit (High Byte)								
	6	Torque Compensation (Low Byte)								
	7	Torque Compensation (High Byte)								
	8	(Reserved)								
	9						Multi-Function Input 12	Multi-Function Input 11	Multi-Function Input 10	Multi-Function Input 9
	10	--	--	--	--	--	--	--	NetCtrl	NetRef
	11	--	--	--	--	--	--	--	--	--
	12	Analog Output FM (Low Byte)								
	13	Analog Output FM (High Byte)								
	14	Analog Output AM (Low Byte)								
	15	Analog Output AM (High Byte)								
	16	Digital Outputs (Low Byte)								
	17	Digital Outputs (High Byte)								
	18	Reserved for Future Use								
	19	Reserved for Future Use								

Parameter	Data
FWD Run	Forward Run Command 0: Stop 1: Forward Run
REV Run	Reverse Run Command 0: Stop 1: Reverse Run
S3	Terminal S3 Function Input 0: Terminal S3 Function (H01-03) OFF 1: Terminal S3 Function (H01-03) ON

Parameter	Data
S4	Terminal S4 Function Input 0: Terminal S4 Function (H01-04) OFF 1: Terminal S4 Function (H01-04) ON
S5	Terminal S5 Function Input 0: Terminal S5 Function (H01-05) OFF 1: Terminal S5 Function (H01-05) ON
S6	Terminal S6 Function Input 0: Terminal S6 Function (H01-06) OFF 1: Terminal S6 Function (H01-06) ON
S7	Terminal S7 Function Input 0: Terminal S7 Function (H01-07) OFF 1: Terminal S7 Function (H01-07) ON
S8	Terminal S8 Function Input 0: Terminal S8 Function (H01-08) OFF 1: Terminal S8 Function (H01-08) ON
External Fault	External Fault EF0 0: No External Fault (EF0) 1: External Fault (EF0)
Fault Reset	Fault Reset 0: No Fault Reset 1: Fault Reset
M0-M1 Digital Output	Terminal M0-M1 0: M0-M1 Open 1: M0-M1 Closed This function is programmed by H02-01.
M2-M3 Digital Output	Terminal M2-M3 0: M2-M3 Open 1: M2-M3 Closed This function is programmed by H02-02.
M5-M6 Digital Output	Terminal M5-M6 0: M5-M6 Open 1: M5-M6 Closed This function is programmed by H02-03.
Speed Reference	Speed Reference [RPM or O01-03]
Torque Reference/ Torque Limit	Torque Reference/Torque Limit Sets the Torque Reference/Torque Limit in units of 0.1%. Sets the Torque Reference when using Torque Control (D05-01 = 0). Sets the Torque Limit when using Speed Control (D05-01 = 1). The Torque Reference and Torque Limit are disabled with F06-06 = 0.
Torque Compensation	Sets the amount of Torque Compensation Sets in units of 0.1%.
Digital Inputs	MEMOBUS/Modbus (0x49). Monitor parameter U01-10
NetReference	Option sets reference
NetCtrl	Option sets control
Analog Output FM	MEMOBUS/Modbus (0x0007)
Analog Output AM	MEMOBUS/Modbus (0x0008)

Parameter	Data																		
Digital Outputs	MEMOBUS/Modbus (0x0009) <table border="1" style="margin-left: auto; margin-right: auto;"> <thead> <tr> <th>8</th> <th>7</th> <th>6</th> <th>5</th> <th>4</th> <th>3</th> <th>2</th> <th>1</th> <th>0</th> </tr> </thead> <tbody> <tr> <td>Fault relay</td> <td>--</td> <td>--</td> <td>--</td> <td>--</td> <td>--</td> <td>M5-M6</td> <td>M2-M3</td> <td>M0-M1</td> </tr> </tbody> </table>	8	7	6	5	4	3	2	1	0	Fault relay	--	--	--	--	--	M5-M6	M2-M3	M0-M1
8	7	6	5	4	3	2	1	0											
Fault relay	--	--	--	--	--	M5-M6	M2-M3	M0-M1											

NOTE: Programmable Bytes contains the data to be written to the MEMOBUS/Modbus address defined in the given parameter. A value of 0 in the given parameter means it is not used, therefore the value received for this given parameter will not be written to any MEMOBUS/Modbus register. If the PPA is Input Assembly 166, then any errors occurring during a write will be flagged. Refer to High Speed/Torque Status Input (Vendor Specific YEA Assy) - 166 (0xA6) on page 36.

9. Input Assemblies (Drive Produces)

NOTE: The convention in this manual is from the PLC perspective. An “Input Assembly” is outputted from this node and read by the PLC. This section details “Input Assemblies” that are “Produced” by this drive.

Extended Speed Control Input - 71 (0x47)

Input Instance	Byte	Bit 7	Bit 6	Bit 5	Bit 4	Bit 3	Bit 2	Bit 1	Bit 0
71	0	At Speed	Ref from Net	Ctrl from Net	Ready	REV Run	FWD Run	Warning	Faulted
	1	Drive State							
	2	Speed Actual (Low Byte)							
	3	Speed Actual (High Byte)							

Parameter	Data
Faulted	Faulted 0: No Faults Occurred 1: Fault Occurred
Warning	Warning 0: No Warning Occurred 1: Warning Occurred
FWD Run	Forward Running 0: Stop or Reverse Running 1: Forward Running
REV Run	Reverse Running 0: Stop or Forward Running 1: Reverse Running
Ready	Drive Ready 0: Not Ready 1: Ready
Ctrl from Net	Status of Run command from Network 0: Run command is not from network 1: Run command is from network
Ref from Net	Status of Speed reference from Network 0: Speed reference is not from network 1: Speed reference is from network
At Speed	Speed Agree 0: No Speed Agree 1: Speed actual at speed reference
Drive State	Contains the value from the Control Supervisor (Class 0x29) Instance 1 Attribute 6.
Speed Actual	Actual Drive Speed (U01-02) Monitors drive output frequency. Speed actual data: Output frequency x 2 ^{SS} (SS: Speed scale) Range: 0 to 0xFFFF For example, when output frequency of 1024 with a speed scale of 2: Speed actual data = 1024 x 2 ² = 4096 = 0x1000 Unit depends on O01-03.

Extended Speed and Torque Control Input - 73 (0x49)

Input Instance	Byte	Bit 7	Bit 6	Bit 5	Bit 4	Bit 3	Bit 2	Bit 1	Bit 0
73	0	At Speed	Ref from Net	Ctrl from Net	Ready	REV Run	FWD Run	Warning	Faulted
	1	Drive State							
	2	Speed Actual (Low Byte)							
	3	Speed Actual (High Byte)							
	4	Torque Actual (Low Byte)							
	5	Torque Actual (High Byte)							

Parameter	Data
Faulted	Faulted 0: No Faults Occurred 1: Fault Occurred
Warning	Warning 0: No Warning Occurred 1: Warning Occurred
FWD Run	Forward Running 0: Stop or Reverse Running 1: Forward Running
REV Run	Reverse Running 0: Stop or Forward Running 1: Reverse Running
Ready	Drive Ready 0: Not Ready 1: Ready
Ctrl from Net	Status of Run command from Network 0: Run command is not from network 1: Run command is from network
Ref from Net	Status of Speed reference from Network 0: Speed reference is not from network 1: Speed reference is from network
At Speed	Speed Agree 0: No Speed Agree 1: Speed actual at speed reference
Drive State	Contains the value from the Control Supervisor (Class 0x29) Instance 1 Attribute 6.
Speed Actual	Actual Drive Speed (U01-02) Monitors drive output frequency. Speed actual data: Output frequency $\times 2^{SS}$ (SS: Speed scale) Range: 0 to 0xFFFF For example, when output frequency of 1024 with a speed scale of 2: Speed actual data = $1024 \times 2^2 = 4096 = 0x1000$ Unit depends on O01-03.
Torque Actual	Output Torque (U01-09) Shows the Torque Reference. Value displays in 0.1% units.

MEMOBUS/Modbus Message Input - 150 (0x96)

Input Instance	Byte	Bit 7	Bit 6	Bit 5	Bit 4	Bit 3	Bit 2	Bit 1	Bit 0
72	0	Function Code							
	1	Register Number (High Byte)							
	2	Register Number (Low Byte)							
	3	Register Data (High Byte)							
	4	Register Data (Low Byte)							

NOTE: This is a paired assembly (100/150).

Table 9: Reply Mapping - 150

Byte	Write Success	Read Success	Write Failure	Read Failure	Invalid Function Code	Function Code Equals Zero
0	0x10	0x03	0x90	0x83	Function Code Or-ed with 0x80	0
1	Output Assembly Register Number (High Byte)	Output Assembly Register Number (High Byte)	Output Assembly Register Number (High Byte)	Output Assembly Register Number (High Byte)	Output Assembly Register Number (High Byte)	0
2	Output Assembly Register Number (Low Byte)	Output Assembly Register Number (Low Byte)	Output Assembly Register Number (Low Byte)	Output Assembly Register Number (Low Byte)	Output Assembly Register Number (Low Byte)	0
3	0	Read Data (High Byte)	0	0	0	0
4	0	Read Data (Low Byte)	Error Code	Error Code	1	0

Table 10: Error replies - 150

Error Code	Description
0x01	Invalid Function Code
0x02	Invalid Register Number
0x21	Upper/Lower Limit Error
0x22	Option generated busy event. The MEMOBUS/Modbus requested operation is in the process loop but the drive is not done yet. Writing "Enter" when drive is running. Attempt to write data that is read only. Attempt to write a constant when drive is running.0 During a CPF03 event attempting to write to registers other than A01-02 to A01-05, E01-03, O02-04.
0x23	Attempting to write during a drive undervoltage (Uv) event.
0x24	Attempting to write while the drive is storing data.

Speed/Torque Status Input - 151 (0x97)

Output Instance	Byte	Bit 7	Bit 6	Bit 5	Bit 4	Bit 3	Bit 2	Bit 1	Bit 0
151	0	FAULT	ALARM	READY	Speed Agree	Reset	REV Running	ZSP	Running
	1	ZSV	--	M5-M6 Digital Output	M2-M3 Digital Output	M0-M1 Digital Output	LOCAL/REMOTE	UV	OPE
	2	Output Frequency (Low Byte)							
	3	Output Frequency (High Byte)							
	4	Torque Actual (Low Byte)							
	5	Torque Actual (Low Byte)							
	6	Actual Current (Low Byte)							
	7	Actual Current (High Byte)							

Parameter	Data
Running	Running 0: Stop 1: Forward or Reverse Running
ZSP	Zero Speed 0: Running 1: Stop or DC Injection Braking
REV Running	Reverse Running 0: Not Reverse Running 1: Reverse Running
Reset	Reset 0: No Reset 1: Reset
Speed Agree	Speed Agree 0: No Speed Agree 1: Speed Actual at speed reference
READY	Drive Ready 0: Not Ready 1: Ready
ALARM	Drive Alarm 0: No Drive Alarm 1: Alarm
FAULT	Drive Fault 0: No Drive Fault 1: Fault
OPE	OPE Fault 0: No OPExx Fault 1: OPExx
UV	Under Voltage 0: No Under Voltage 1: Under Voltage

Parameter	Data
Local/Remote	Status of Run command from Network 0: Run command is not from network 1: Run command is from network
M0-M1 Digital Output	Terminal M0-M1 0: M0-M1 Open 1: M0-M1 Closed This function is programmed by H02-01.
M2-M3 Digital Output	Terminal M2-M3 0: M2-M3 Open 1: M2-M3 Closed This function is programmed by H02-02.
M5-M6 Digital Output	Terminal M5-M6 0: M5-M6 Open 1: M5-M6 Closed This function is programmed by H02-03.
ZSV	Zero Servo (Load Float) Active 0: Not in Load Float 1: In Load Float
Output Frequency	Actual Drive Speed (U01-02) Monitors drive output frequency. Unit depends on O01-03. Unit is not affected by Speed Scale SS.
Torque Actual	Output Torque (U01-09) Shows the Torque Reference. Value displays in 0.1% units.
Actual Current	Actual Output Current (U01-03) Monitors drive output current. Unit is 0.01 A. Unit is not affected by Current Scale CS.

High Speed/Torque Status Input - 166 (0xA6)

If an error occurs while trying to read from the dynamic parameters, the appropriate error bit in Assembly 166 will be set. If more information about the nature of the error is needed, the extended error status can be read explicitly through Class 0xA6, Instance 1, Attribute 0x64. This will return 20 Bytes with each dynamic parameter in Assembly 166 having a Byte dedicated to its extended error status.

Input Instance	Byte	Bit 7	Bit 6	Bit 5	Bit 4	Bit 3	Bit 2	Bit 1	Bit 0
166	0	FAULT	ALARM	READY	Speed Agree	Reset	REV Running	ZSP	Running
	1	ZSV	--	M5-M6 Digital Output	M2-M3 Digital Output	M0-M1 Digital Output	LOCAL/REMOTE	UV	OPE
	2	Motor Speed (Low Byte)							
	3	Motor Speed (High Byte)							
	4	Torque Actual (Low Byte)							
	5	Torque Actual (Low Byte)							
	6	PG Count Value (Low Byte)							
	7	PG Count Value (High Byte)							
	8	Frequency Command (Low Byte)							
	9	Frequency Command (High Byte)							
	10	Output Frequency (Low Byte)							
	11	Output Frequency (High Byte)							
	12	Output Current (Low Byte)							
	13	Output Current (High Byte)							
	14	DC Bus Voltage (Low Byte)							
	15	DC Bus Voltage (High Byte)							
	16	Main Circuit DC Voltage (Low Byte)							
	17	Main Circuit DC Voltage (High Byte)							
	18	Error Code (Low Byte)							
	19	Error Code (High Byte)							

Parameter	Data
Running	Running 0: Stop 1: Forward or Reverse Running
Zero Speed	Zero Speed 0: Running 1: Stop or DC Injection Braking
REV Running	Reverse Running 0: Not Reverse Running 1: Reverse Running
Fault Reset	Fault Reset command from Network 0: Fault Reset command is not from network 1: Fault Reset command is from network

Parameter	Data
Speed Agree	Speed Agree 0: No Speed Agree 1: Speed actual at speed reference
READY	Drive Ready 0: Not Ready 1: Ready
ALARM	Drive Alarm 0: No Drive Alarm 1: Alarm
FAULT	Drive Fault 0: No Drive Fault 1: Fault
OPE	OPE Fault 0: No OPExx fault 1: OPExx
Uv	Under Voltage 0: No Under Voltage 1: Under Voltage
Local/Remote	Status of Run command from Network 0: Run command is not from Network 1: Run Command is from Network
M0-M1 Digital Output	Terminal M0-M1 0: M0-M1 Open 1: M0-M1 Closed This function is programmed by H02-01.
M2-M3 Digital Output	Terminal M2-M3 0: M2-M3 Open 1: M2-M3 Closed This function is programmed by H02-02.
M5-M6 Digital Output	Terminal M5-M6 0: M5-M6 Open 1: M5-M6 Closed This function is programmed by H02-03.
ZSV	Zero Servo (Load Float) Active 0: Not in Load Float 1: In Load Float
Motor Speed	Motor Speed (U01-05)
Torque Actual	Output Torque Shows the Torque Reference. Value displays in 0.1% units.
PG Count Value	Contained MEMOBUS/Modbus Address
Frequency Command	Frequency Reference (U01-01)
Output Frequency	Actual Drive Speed (U01-02) Monitors drive output frequency. Unit depends on O01-03. Unit is not affected by Speed Scale SS.
Output Current	Actual Output Current (U01-03) Monitors drive output current. Unit is 0.01 A Unit is not affected by Current Scale CS.

Parameter	Data
DC Bus Voltage	MEMOBUS/Modbus (0x46) Monitor parameter U01-07
Main DC Voltage	DC Bus Voltage (U01-07)
Error Code	U02-01 converted using fault code table

Possible extended error codes are listed in Table 11. On Assembly 116, the only error that can be declared is 0x02.

Table 11: Extended Error Codes for Assembly 116/166

Error Code	Description
0x00	No Error
0x01	Sub function code failure
0x02	Register number failure
0x21	Limit check error failure
0x22	Write failure
0x23	Write failure at Uv
0x24	Write failure at busy

10. General Class Objects

Identity Object 1 (Class 0x01)

Services Supported

Service Code No. (hex)	Service Name
01	Get Attribute All
05	Reset
0E	Get Attribute Single

Attributes Supported

Instance ID	Attribute	Name	Description	Get	Set	Size	Default
0	1	Object Software Revision	Identity Object software revision	O	--	Word	1
1	1	Vendor ID	Manufacturer code. 44 (2C Hex): Yaskawa Electric	O	--	Word	44
1	1	Device Type	Device profile. The profile for this product is an AC drive. 2: AC drive	O	--	Word	2 (AC drives)
1	3	Product Code	Product codes determined by the manufacturer.	O	--	Word	*1
1	4	Revision	Software revision for the option.	O	--	Word	Depends on software
1	5	Status	Shows the communication status for the drive.	O	--	Word	0
1	6	Serial Number	Option serial number.	O	--	Long	Each unit is unique
1	7	Product Name	Product Name	O	--	String (14 Bytes)	Product dependent (i.e., CIMR-X)
1	8	State	Operation status of the drive. 3: Drive ready 4: Fault	O	--	Byte	3

NOTE: *1 Product code is 2 Bytes. The first Byte is the drive type and the second Byte is the model number of the drive.

Instance ID	Attribute	Name	Description	Get	Set	Size	Default
166	3	Data	Same function as the High Speed/Torque Status (Input Assembly)	0	--	Array 44 bytes	00 00

Control Supervisor Object 41 (Class 0x29)

Services Supported

Service Code No. (hex)	Service Name
0E	Get Attribute Single
10	Set Attribute Single
05	Reset

Attributes Supported

Instance ID	Attribute	Name	Description	Get	Set	Size	Default
0	1	Object Software Revision	Revision number of the Control Supervisor Object.	O	--	Word	1
1	3	FWD Run	Forward Running 0: Stop 1: Forward Running	O	O	Byte	0
1	4	REV Run	Reverse Running 0: Stop 1: Reverse Running	O	O	Byte	0
1	5	NetCtrl (Command)	Run command from Network 0: Depends on B03-02 1: Enables the run command from network	O	O	Byte	0
1	6	State	Drive Status. 2: Not Ready 3: Ready (Stopped) 4: Enabled (Run command present) 5: Deceleration to Stop 6: Fault Stop 7: Fault	O	--	Byte	3
1	7	FWD Run	Forward Running 0: Stop 1: Forward Running	O	--	Byte	0
1	8	REV Run	Reverse Running 0: Stop 1: Reverse Running	O	--	Byte	0
1	9	Ready	Drive Ready 0: Not Ready 1: Ready	O	--	Byte	1
1	10	Fault	Drive Fault 0: No Drive Fault 1: Fault	O	--	Byte	0
1	11	Warning	Warning 0: No Warning 1: Warning	O	--	Byte	0
1	12	Fault Reset	Fault Reset 0: No Fault Reset 1: Fault Reset	O	O	Byte	0

Instance ID	Attribute	Name	Description	Get	Set	Size	Default
1	13	Fault Code	Current Fault Refer to Option Fault Code Conversion Table for details	O	--	Word	0000
1	15	Control form Net (Status)	Run Command from the option 0: The run command is not from the option 1: Enables the run command from option	O	--	Byte	0
1	16	EtherNet/IP Fault Mode	Normal 2 (Vendor Specific)	O	--	Byte	2
1	17	Force Fault	External Fault 0: No External Fault 1: External Fault (EF0) Triggered by the rising edge of the signal.	O	O	Byte	0
1	18	Force Reset	External Fault status 0: No External Fault 1: External Fault (EF0) Triggered by the rising edge of the signal.	O	--	Byte	0

Option Fault Code Conversion Table

Drive Fault Code (Dec) (MEMOBUS/Modbus #0080 hex)	Option Fault Code (hex)	Description
0	0000	None
2	3220	DC Bus Undervolt (Uv1)
3	5110	CTL PS Undervolt (Uv2)
4	3222	MC Answerback (Uv3)
6	2120	Ground Fault (GF)
7	2300	Over Current (oC)
8	3210	DC Bus Overvolt (ov)
9	4200	Heatsink Overtemp (oH)
10	4210	Heatsink Max Temp (oH1)
11	2220	Motor Overload (oL1)
12	2200	Inv Overload (oL2)
13	2221	Overtorque Det 1 (oL3)
14	2222	Overtorque Det 2 (oL4)
15	7110	DynBrk Transistor (rr)
16	7112	DynBrk Resistor (rH)
17	9000	External Fault 3 (EF3)
18	9000	External Fault 4 (EF4)
19	9000	External Fault 5 (EF5)
20	9000	External Fault 6 (EF6)
21	9000	External Fault 7 (EF7)

Drive Fault Code (Dec) (MEMOBUS/Modbus #0080 hex)	Option Fault Code (hex)	Description
24	7310	Overspeed Det (oS)
25	7310	Speed Deviation (dEv)
26	7301	PG Open (PGo)
27	3130	Input Phase Loss (PF)
28	3130	Output Phase Loss (LF)
30	5300	Operator Disconnected (oPr)
31	6320	EEPROM R/W Error (Err)
33	7500	MEMBOUS/Modbus Com Fault (CE)
34	7500	EtherNet/IP Communication Error (bUS)
37	8321	Out of Control (CF)
39	9000	External Fault 0 (EF0)
40	8000	PID Feedback Loss (FbL)
41	8000	Undertorque Detection 1 (UL3)
42	8000	Undertorque Detection 2 (UL4)
43	8000	High Slip Braking oL (oL7)
50	8000	Z Pulse Fall Detection (dv1)
51	8000	Z Pulse Noise Fault Detection (dv2)
52	8000	Inversion Detection (dv3)
53	8000	Inversion Prevention Detection (dv4)
54	8000	Current Imbalance (LF2)
55	8000	Pull-Out Detection (STo)
56	7000	PG Hardware Fault (PGoH)
59	1000	Too Many Speed Search Restarts (SEr)
65	8000	Excessive PID Feedback (FbH)
66	9000	External Fault (input terminal S1) (EF1)
67	9000	External Fault (input terminal S2) (EF2)
68	8000	Mechanical Weakening Detection 1 (oL5)
69	8000	Mechanical Weakening Detection 2 (UL5)
70	5000	Current Offset Fault (CoF)
73	8000	DriveWorksEZ Fault (dwFL)
77	5000	Output Voltage Detection Fault (voF)
78	7000	Braking Resistor Fault (rF)
79	7000	Braking Transistor Overload Fault (boL)
--	1000	Other faults

AC/DC Drive Object 42 (Class 0x2A)

Services Supported

Service Code No. (hex)	Service Name
0E	Get Attribute Single
10	Set Attribute Single

Attributes Supported

Instance ID	Attribute	Name	Description	Get	Set	Size	Default
0	1	Object Software Revision	Revision number of AC/DC drive object	O	--	Word	1
1	3	Speed Agree	Speed Agree 0: — 1: Speed Agree	O	--	Byte	0
1	4	NetRef (Command)	Status of reference command from EtherNet/IP 0: Reference command from the option 1: Reference command not from option	O	--	Byte	0
1	6	Drive Mode	Drive control mode. 0: OLV 1: V/f Control 3: Flux Vector	O	O	Byte	0
1	7	Speed Actual	Actual drive speed. Unit is not affected by Speed Scale (SS).	O	--	Word	3
1	8	Speed Reference	Frequency Reference. Monitors the drive's frequency reference. Unit is not affected by Speed Scale (SS).	O	O	Word	0
1	9	Current Actual	Actual Output Current. Unit is 0.01 A for drives set up to 11 kW in Heavy Duty or Normal Duty and 0.1 A for drives set up for 15 kW and above. Unit is not affected by Current Scale (CS).	O	--	Word	0
1	11	Torque Actual	Drive Output Torque Unit is affected by Torque Scale (TS)	O	--	Word	0

Instance ID	Attribute	Name	Description	Get	Set	Size	Default
1	12	Torque References/ Torque Limit	Torque Reference/Torque Limit Sets the Torque Reference/ Torque Limit. The units are determined by the Torque Scale. Sets the Torque Reference when using Torque Control (D05-01 = 1). Sets the Torque Limit when using Speed Control (D05-01 = 0) The Torque Reference/Torque Limit are disabled when F6-06 = 0.	0	0	Word	0
1	15	Power Actual (W)	Drive Output Power Unit is affected by Power Scale (PS).	0	--	Word	0
1	16	Input Voltage (V)	Drive Input Voltage Unit is affected by Voltage Scale (VS).	0	--	Word	Depends on Capacity
1	17	Output Voltage (v)	Drive Output Voltage Unit is affected by Voltage Scale (VS).	0	--	Word	0
1	18	Accel Time (ms)	Acceleration Time 1 (B05-01) Units set in parameter B05-09. Unit is affected by Time Scale (TS).	0	0	Word	2710 h
1	19	Decel Time (ms)	Acceleration Time 1 (B05-02) Units set in parameter B05-09. Unit is affected by Time Scale (TS).	0	0	Word	2710 h
1	20	Low Speed Limit Percent of Max Speed	Frequency Reference Lower Limit (D02-02)	0	0	Word	0
1	21	High Speed Limit Percent of Max Speed	Frequency Reference Upper Limit (D02-01)	0	0	Word	3E8 h
1	22	Speed Scale (-15 ~ 15)	Setting for F06-56, scale of units for speed related data.	0	0	Byte	0
1	23	Current Scale (-15 ~ 15)	Setting for F06-57, scale of units for current related data.	0	0	Byte	0
1	24	Torque Scale (-15 ~ 15)	Setting for F06-58, scale of units for torque related data.	0	0	Byte	0
1	26	Power Scale (-15 ~ 15)	Setting for F06-59, scale of units for power related data.	0	0	Byte	0
1	27	Voltage Scale (-15 ~ 15)	Setting for F06-60, scale of units for voltage related data.	0	0	Byte	0
1	28	Time Scale (-15 ~ 15)	Setting for F06-61, scale of units for speed related data.	0	0	Byte	0
1	29	Reference from Net (Status)	Status of Reference Command (1 = Network). 0: As set by the drive parameters (i.e., B03-01) 1: Network	0	--	Byte	0

TCP/IP Object 245 (Class 0xF5)

Services Supported

Service Code No. (hex)	Service Name
01	Get Attribute All
0E	Get Attribute Single
10	Set Attribute Single

Attributes Supported

Instance ID	Attribute	Name	Description	Get	Set	Size	Range	Default
0	1	Object Software Revision	Revision number of the TCP/IP Object	O	--	Word	--	1
1	1	Status	Bits 0-3 = Interface Status 0: Interface has not been configured 1: Interface Configuration is valid, obtained from BOOTP, DHCP, or NVRAM 2: Interface Configuration is valid and obtained from hardware settings 3: Reserved Bit 4 = Multicast Pending Bits 5-31 = Reserved	O	--	DWord	--	--
1	2	Configuration Capability	Bit 0 = BOOTP Client Bit 1 = DNS Client Bit 2 = DHCP Client Bit 3 = DHCP-DNS Update Bit 4 = Configuration Settable Bits 5-31 = Reserved	O	--	DWord	--	--
1	3	Configuration Control	Bits 0-3 = Startup Configuration 0: NVRAM 1: BOOTP 2: DHCP 3: Reserved Bit 4 = DNS Enabled (not supported) Bits 5-31 = Reserved	O	O	DWord	0 - 2h	
1	4	Physical Link	Struct of: Path Size: Word Path: EPATH	O	--	Struct	--	02h 00h 20h F6h 24h 01h
1	5	Interface Configuration	Struct of: IP Address = Long Subnet Mask = Long Gateway Address = Long Name Server1 = Long Name Server2 = Long Domain Name = STRING	O	O	Struct	--	--
1	6	Host Name	Host Name	O	O	STRING	64 Characters	Null

NOTE: "Get Attributes All" Service shall report in attribute ascending order.

Ethernet Link Object 246 (Class 0xF6)

Services Supported

Service Code No. (hex)	Service Name
01	Get Attribute All
0E	Get Attribute Single
10	Set Attribute Single

Attributes Supported

Instance ID	Attribute	Name	Description	Get	Set	Size	Range	Default
0	1	Object Software Revision	Revision number of the Ethernet Link Object	O	--	Word	--	3
1	1	Interface Speed	Interface speed currently in use	O	--	UDINT	--	--
1	2	Interface Flags	Bit 0 = Link Status Bit 1 = Duplex (0: Half/1: Full) Bits 2-4 = Negotiation Status 0: In progress 1: Auto-negotiate failed 2: Speed found, duplex not found- -no defaulted duplex 3: Successful 4: Not attempted Bit 5 = Manual Setting requires restart Bit 6 = Local hardware fault Bits 7-31 = Reserved	O	--	DWord	--	--
1	3	Physical Address (MAC)	MAC layer address	O	--	Array of 6 Bytes	--	--
1	6	Interface Control	Struct of: Control Bits: Word Bit 0 = Auto-negotiate Bit 1 = Forced Duplex Mode Bits 2-15 = Reserved Forced Int Speed: Word	--	O	Struct	--	--

NOTE: "Get Attributes All" Service shall report in attribute ascending order.

11. Vendor-Specific (Yaskawa) Class Objects

Yaskawa Drive Parameters Object 100 (Class 0x64)

Services Supported

Service Code No. (hex)	Service Name
0E	Get Attribute Single
10	Set Attribute Single

This is a dynamic explicit Class Object. With this Class object any drive parameter with a MEMOBUS/Modbus address greater than 0x00FF can be accessed. The mapping of Class Object instance/attribute to MEMOBUS/Modbus address is as follows.

Given a typical MEMOBUS/Modbus Address of 0xXXYY

The EtherNet/IP Instance value is equal to XX

The EtherNet/IP Attribute value is equal to YY

As an example, to access parameter C01-05 (MEMOBUS/Modbus Address =0x01B0)

Class Object is 100 (0x64) (Always for this Class Object)

Instance = 0x01

Attribute = 0xB0

Storing Changed Parameters

Writing a zero to 0x0900 (Enter) stores changed parameters to the non-volatile memory of the drive. Writing a 0 to 0x0910 (Accept) allows the drive to use the changed parameters. Reading Enter Command 0x0900 or Accept Command 0x910 will always return a value of 0x0001.

Performing a RAM-ENTER to Store Register Data

Parameter H5-11 is used to decide whether a RAM-ENTER will be done on the writes to registers in the drive. If H5-11 = 1 (default), the option will issue the RAM-ENTER with the parameter writes. If H5-11 = 0, no RAM-ENTER is issued and an ENTER command must be explicitly sent by the user for the parameter to be activated after a write.

Explicit writes to RAM-ENTER (0x910) and ROM-ENTER (0x900) are handled as special cases. If a user writes a 0 to RAM-ENTER or ROM-ENTER, the command will be executed in the drive. If a user writes a 1 to those registers, the command will not be executed but returns a success to the explicit write on the network. Writing a value other than 0 or 1 will result in an error response of Invalid Attribute Value on the network.

NOTE: Performing the RAM-ENTER increases the processing time of the writes and increases the response time to explicit writes.

Attributes Supported

Instance ID	Attribute	Name	Description	Get	Set	Size	Default
0	1	Object Software Revision	Yaskawa Drive Parameters object software revision	O	--	Word	1
1	00	MEMOBUS/Modbus Register 0x0100	Language selection	O	O	Word	1
1	01	MEMOBUS/Modbus Register 0x0101	Parameter access level	O	O	Word	2
1	YY	MEMOBUS/Modbus Registers 0x0100 ~ 0x01FF	MEMOBUS/Modbus Registers 0x0100 ~ 0x01FF	O	O	Word	--
2	YY	MEMOBUS/Modbus Registers 0x0200 ~ 0x02FF	MEMOBUS/Modbus Registers 0x0200 ~ 0x02FF	O	O	Word	--
...	O	Word	--
255	YY	MEMOBUS/Modbus Registers 0xFF00 ~ 0xFFFF	MEMOBUS/Modbus Registers 0xFF00 ~ 0xFFFF			Word	--

- NOTE:**
1. Attempting to set a read-only parameter results in a EtherNet/IP error code of 0x0E, *Attribute Not Settable*.
 2. Attempting to access an invalid parameter results in a EtherNet/IP error code of 0x09, *Invalid Attribute Value*.
 3. Refer to the MEMOBUS/Modbus Data Table in Appendix C of the drive Technical Manual for a list of monitor data using the MEMOBUS/Modbus message area.

Yaskawa Monitor/Control Object 125 (Class 0x7D)

Services Supported

Service Code No. (hex)	Service Name
0E	Get Attribute Single
10	Set Attribute Single

This is a dynamic explicit Class Object. With this Class object any parameter with a MEMOBUS/Modbus address less than 0x0100 can be accessed. This class is similar to the Drive Parameters Object Class 100, except the most significant Byte of MEMOBUS/Modbus address is always zero, the instance in this class remains at 1.

Given a typical MEMOBUS/Modbus Address Of 0x00YY

The EtherNet/IP Instance value is equal to 0x01

The EtherNet/IP Attribute value is equal to YY

As an example, to access Drive Status (MEMOBUS/Modbus Address = 0x002C)

Class Object is 125 (0x7D) (Always for this Class Object)

Instance = 0x01

Attribute = 0x2C

Attributes Supported

Instance ID	Attribute	MEMOBUS/Modbus Address	Description	Get	Set	Size
0	1	--	Object Software Revision	O	--	Word
1	1	0x0001	Drive Command Bits	O	O	Word
1	2	0x0002	Frequency Instruction	O	O	Word
...	O	O	Word
1	255	0x00FF	Unused	O	O	Word

NOTE:

1. Attempting to set a read-only parameter results in a EtherNet/IP error code of 0x0E, Attribute Not Settable.
2. Attempting to access an invalid parameter results in a EtherNet/IP error code of 0x09, Invalid Attribute Value.
3. Refer to the MEMOBUS/Modbus Data Table in Appendix C of the drive Technical Manual for a list of monitor data using the MEMOBUS/Modbus message area.

12. Web Interface

The web server interface to the option allows management of diagnostic information through a standard web browser. The embedded web pages include:

- Main page
- Drive Status page
- Network Monitor page
- Documentation page

Main Page

The embedded main page shows basic option information such as vendor ID, serial number, MAC address, and firmware version. This page also shows the status of the option, and provides links to the other embedded web pages.

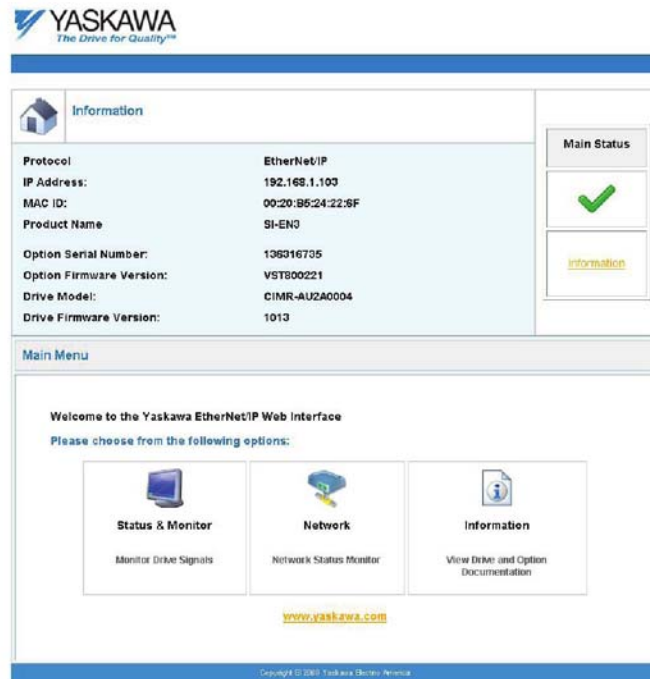

Figure 10: Main Page View

Drive Status Page

The embedded drive status page shows basic I/O information and drive state information.

YASKAWA
The Drive for Quality™

Status, Monitor and Fault History

Drive Signals

Stopped	On	Forward	On	Alarm	Off
Running	Off	Reverse	Off	Fault	Off

Drive Signals		Multi-function Inputs		Multi-function Outputs	
Frequency Ref.	0.00 Hz	Terminal S1	Off	Output MAMB-MC	Off
Output Frequency	0.00 Hz	Terminal S2	Off	Output P1 - FC	On
Output Current	0.0 A	Terminal S3	Off	Output P2 - FC	Off
DC Bus Voltage	304 VDC	Terminal S4	Off		
Torque Ref	0.0 %	Terminal S5	Off		
		Terminal S6	Off		
		Terminal S7	Off		
		Terminal S8	Off		
		Terminal S9	NA		
		Terminal S10	NA		
		Terminal S11	NA		
		Terminal S12	NA		

Analog Input Signals

Input Terminal A1	0.0 %
-------------------	-------

Fault Information

Active: None

Copyright ©2009 Yaskawa Electric America

Figure 11: Drive Status Page View

Network Monitor Page

The embedded network monitor page shows the status of the option network traffic and open I/O connections.



Figure 12: Network Monitor Page View

Documentation Page

The embedded documentation page contains links to option documentation on the Yaskawa website.



Figure 13: Documentation Page View

13. Troubleshooting

Drive-Side Error Codes

Drive-side error codes appear on the drive digital operator. Causes of the errors and corrective actions are listed in Table 12. For additional error codes that may appear on the drive digital operator, refer to the drive Quick Start Guide or Technical Manual.

Faults

Both bUS (Option communication error) and EF0 (External fault input from the option) can appear as an alarm or as a fault. When a fault occurs, the digital operator ALM LED remains lit. When an alarm occurs, the ALM LED flashes.

If communication stops while the drive is running, use the following questions as a guide to help remedy the fault:

- Is the option properly installed?
- Is the communication line properly connected to the option? Is it loose?
- Is the controller program working? Has the controller/PLC CPU stopped?
- Did a momentary power loss interrupt communications?

Table 12: Fault Displays, Causes, and Possible Solutions

LED Operator Display		Fault Name
bUS	bUS	Option Communication Error.
		<ul style="list-style-type: none"> • After establishing initial communication, the connection was lost • Only detected when the run command or frequency reference is assigned to the option (B01-01 = 3 or B01-02 = 3)
Cause		Possible Solution
Master controller (PLC) has stopped communicating		<ul style="list-style-type: none"> • Check that power is supplied to the PLC • Check that PLC is not in program mode
Communication cable is not connected properly		<ul style="list-style-type: none"> • Check for faulty wiring • Correct any wiring problems
A data error occurred due to noise		<ul style="list-style-type: none"> • Inspect items that can minimize the effects of electrical noise • Counteract noise in the control circuit, main circuit, and ground wiring • If a magnetic contactor is identified as a source of noise, install a surge absorber to the contactor coil • Make sure the cable used meets the EtherNet/IP requirements • Make sure the option ground wire is connected between option FE terminal and the drive ground terminal connected to earth ground
Option is damaged		If there are no problems with the wiring and the error continues to occur, replace the option.
Connection Time-out		The option Requested Packet Interval (RPI) timer timed out. Make sure that RPI time is set properly.
Duplicate IP Address		The option shares IP Address with at least one other node.

LED Operator Display		Fault Name
<i>EFO</i>	EFO	External Fault Input from the option.
		The alarm function for an external device has been triggered.
Cause		Possible Solution
An external fault is being sent from the upper controller (PLC)		<ul style="list-style-type: none"> Remove the cause of the external fault Reset the external fault input from the PLC device
Problem with the PLC program		Check the program used by the PLC and make the appropriate corrections.

LED Operator Display		Fault Name
<i>oFA00</i>	oFA00	Option Card Connection Error at Option Port CN5-A
Cause		Possible Solution
The option card installed into port CN5-A is incompatible with the drive		Make sure that a comm. option, a digital input option, or an analog input option is installed in the proper option port. The same type of card cannot be installed twice.

LED Operator Display		Fault Name
<i>oFA01</i>	oFA01	Option Card Fault at Option Port CN5-A
		Option not properly connected
Cause		Possible Solution
The option board connection to port CN5-A is faulty		<ul style="list-style-type: none"> Turn the power off and reconnect the option card. Check if the option card is properly plugged into the option port. Make sure the card is fixed properly. If the option is not a communication option card, try to use the card in another port. If the option card works properly in a different option port, replace the drive because CN5-A is damaged. If the error persists (oFb01 or oFC01 occur), replace the option board.

LED Operator Display		Fault Name
<i>oFA03</i>	oFA03	Option card error occurred at option port CN5-A.
Cause		Possible Solution
Option card or hardware is damaged		<ul style="list-style-type: none"> • Cycle power to the drive. • if the problem continues, replace the control board or the entire drive. Contact Magnetek or a Magnetek representative for instructions on replacing the control board.

LED Operator Display		Fault Name
<i>oFA04</i>	oFA04	Option card error occurred at option port CN5-A
Cause		Possible Solution
Option card or hardware is damaged		<ul style="list-style-type: none"> • Cycle power to the drive. • If the problem persists, replace the control board or the entire drive. Contact Magnetek or a Magnetek representative for instructions on replacing the control board.

LED Operator Display		Fault Name
<i>oFA30 to oFA43</i>	oFA30 to oFA43	Option card error occurred at option port CN5-A
Cause		Possible Solution
Option card or hardware is damaged		<ul style="list-style-type: none"> • Cycle power to the drive. • If the problem persists, replace the control board or the entire drive. Contact Magnetek or a Magnetek representative for instructions on replacing the control board.

LED Operator Display		Fault Name
<i>oFb00</i>	oFb00	Option fault (CN5-B).
		Two of the same options are connected at the same time.
Cause		Possible Solution
Non-compatible option connected to the drive.		Connect the correct option to CN5-A.

LED Operator Display		Fault Name
oFb02	oFb02	Option fault (CN5-B).
		Non-compatible option is connected.
Cause		Possible Solution
Options AI-A3 or DI-A3 are connected to the CN5-B port with an option connected to CN5-A.		<ul style="list-style-type: none"> Only one type of AI-A3 or DI-A3 option can be connected to the drive. The SI-EN3 option can only be connected to CN5-A.

LED Operator Display		Fault Name
oFc00	oFc00	Option Card Connection Error at Option Port CN5-C
Cause		Possible Solution
A communication option card has been installed in option port CN5-C/CN5-B		Communication option cards are only supported by option port CN5-A. It is not possible to install more than one comm. option.

LED Operator Display		Fault Name
oFc02	oFc02	Option Card Fault at Option Port CN5-C
Cause		Possible Solution
An option card of the same type is already installed in option port CN5-A or CN5-B.		Make sure that a comm. option, a digital input option, or an analog input option is installed in the proper option port. The same type of card cannot be installed twice.

Minor Faults and Alarms

LED Operator Display		Fault Name	
CALL	CALL	Serial communication transmission error.	
		Communication is not established.	
Cause		Possible Solution	Minor Fault (H02-XX = 10)
Communication wiring is faulty, there is a short circuit, or improper connection		<ul style="list-style-type: none"> • Check for wiring errors • Correct the wiring • Remove ground shorts and reconnect loose wires 	YES
Programming error on the master side		Check communications at start-up and correct programming errors.	
Communication circuitry is damaged.		<ul style="list-style-type: none"> • Perform a self-diagnostics check • Replace the drive if the fault continues to occur 	

Explicit Message Communications Errors

When there is a problem with a request message sent from the master in explicit communications, the drive will return one of the following error codes.

Error Code (hex)	Description	Cause	Possible Solution
08	Service not supported	The service code is incorrect.	Correct the service code.
09	Invalid attribute value	The attribute is incorrect.	Correct the attribute.
0C	Object state conflict	Attempted to change an drive constant that cannot be changed while the drive is running.	Stop the drive.
0E	Attribute not settable	Attempted to change a read-only attribute.	Correct the service code or attribute setting.
13	Not enough data	The data size is incorrect.	Correct the data size.
14	Attribute not supported	Attempted to execute a service not defined for the attribute.	Correct the service code or attribute setting.
15	Too much data	The data size is incorrect.	Correct the data size.
16	Object does not exist	An unsupported object was specified.	Correct the class or instance setting.
1F	Vendor-specific error	<ul style="list-style-type: none"> Attempted to change a drive constant that cannot be changed while the drive is running Attempted to change a drive constant to a value outside the setting range 	Stop the drive. Specify a value within the setting range.
20	Invalid parameter	Attempted to change to a data value outside the setting range.	Specify a data value within the setting range.

NOTE: Refer to the MEMOBUS/Modbus Data Table in Appendix C of the drive Technical Manual to obtain a list of monitor data using the MEMOBUS/Modbus message area.

Option Error Codes

Option Fault Monitors U6-98 and U6-99

The option can declare error/warning conditions via drive monitor parameters on the drive digital operator as shown in Table 13.

Table 13: Option Fault Monitor Descriptions

Fault Condition	Fault Declared	Status Value (U6-98/U6-99)	Description
No Fault	N/A	0	No faults.
Force Fault	EF0	3	Network sent a message to force this node to the fault state.
Network Link Down	BUS ERROR	1100	No network link to option board.
Connection Time-out	BUS ERROR	1101	The node timer (Requested Packet Interval) timed out.
Duplicate IP Address	BUS ERROR	1102	This node and at least one other node have the same IP Address.
Default MAC Address	None	1103	Factory default MAC Address programmed into the option. Return for reprogramming.

Two drive monitor parameters, U06-98 and U06-99 assist the user in network troubleshooting.

- U06-98 displays the first declared fault since the last power cycle. U06-98 is only cleared upon drive power-up.
- U06-99 displays the present option status. U06-99 is cleared upon a network-issued fault reset and upon power-up.

If another fault occurs while the original fault is still active, parameter U06-98 retains the original fault value and U06-99 stores the new fault status value.

Option Compatibility

A limited number of options may be simultaneously connected to the drive depending on the type of option. Refer to Table 14 for more information. More details can be found in the drive's Installation Manual.

Table 14: Option Installation Compatibility

Option	Connector	Number of Possible Options
SI-C3, SI-N3, SI-P3, SI-S3, SI-EN3 <1>	CN5-A	1
PG-B3, PG-X3	CN5-B, C	2 <2>
DO-A3, AO-A3, AI-A3, DI-A3	CN5-A, B, C	1

<1> When installed in CN5-A, the AI-A3 and DI-A3 options can be used to set the frequency reference or replace the drive analog inputs with higher resolution. When installed in CN5-B or CN5-C, these options can only be used for monitoring; their input levels will be displayed in U01-17 and U01-21 to U01-23.

<2> Use the CN5-C connector when connecting only one option to the drive; use both CN5-B and CN5-C when connecting two options.

13. Specifications

Table 15: Option Specifications

Items	Specifications
Model	SI-EN3
SI-EN3 Supported Messages	<ul style="list-style-type: none"> • Explicit: Explicit Class 3, Unconnected • I/O: Class 1, Listen Only, Input Only
I/O Assembly Instance	<ul style="list-style-type: none"> • Input: 7 types (4~44 Bytes) • Output: 7 types (4~44 Bytes)
SI-EN3 Specification	Conformance Level A6: Passed
SI-EN3 Profile	AC Drive
Connector Type	RJ45 8-pin Straight Connector STP CAT5e cable
Physical Layer Type	<ul style="list-style-type: none"> • Isolated Physical Layer • TCP Protocol Transformer Isolated
IP Address Setting	Programmable from drive keypad or network
Communication Speed	Programmable from drive keypad or network: 10/100 Mbps, auto-negotiate
Number of Connections	<ul style="list-style-type: none"> • I/O: 2 • Explicit: 6
Duplex Mode	Half-forced, Auto-negotiate, Full-forced
Address Startup Mode	Static, BOOTP, DHCP
Ambient Temperature	-10 °C to +60 °C (14 °F to 140 °F)
Humidity	95% RH or lower with no condensation
Storage Temperature	-20 °C to +60 °C (-4 °F to 158 °F) allowed for short-term transport of the product
Area of Use	Indoor (free of corrosive gas, airborne particles, etc.)
Altitude	1000 m (3280 ft.) or lower