

DT Heavy Duty Disc Brakes

Mondel DT Heavy Duty Disc Brakes Instruction Manual



MAGNETEK
MATERIAL HANDLING

Mondel

Part Number: 560005-R1

February 2006

© Copyright 2006 Magnetek Material Handling



MAGNETEK
MATERIAL HANDLING

Mondel

Installation and Maintenance Instructions

DT Heavy Duty Disc Brakes

SUPPLEMENTS FORMING PART OF THIS MANUAL:

DATE OF MANUFACTURE:

APPLICABLE DIMENSION PRINT:

EXPLODED VIEW:

PARTS LIST:

Table of Contents

Chapter 1.0: DT Heavy Duty Disc Brakes Warnings and Cautions 4
Chapter 2.0: General Description 6
Chapter 3.0: Installation 8
Chapter 4.0: Adjustment..... 10
Chapter 5.0: Actuator Delay Adjustment (Optional Feature) Refer to Fig. 5 14
Chapter 6.0: Operational Test..... 15
Chapter 7.0: Inspection and Maintenance 16
Chapter 8.0: Brake Pad Replacement Refer to Fig. 6..... 17

Chapter 1.0: DT Heavy Duty Disc Brakes Warnings and Cautions

These instructions contain safety recommendations for users. Read and follow the information contained in these instructions and any standards referred to.

If a brake is not installed immediately, it may require protection. For long-term storage, consult factory for details.

Chapter 3: INSTALLATION – Warnings and Cautions

Anyone involved in the installation or service of this brake must have:

- Received specific training.
- Had experience on similar equipment.
- Knowledge of the equipment on which the brake is installed.
- The ability to understand the terminology.
- The ability to understand the diagrams.

Do not proceed unless technically qualified for the work involved.

Ensure that all suspended loads or systems, subject to the effects of gravity, wind or otherwise, having the potential of causing the mechanism to move when the brake is released, removed, or being worked on, are blocked or supported in a satisfactory manner, totally independent of the brake.

Hazardous voltage can cause burns, injury, or death. Consult the diagrams to identify and switch off, lock open, and tag the appropriate disconnecting devices. This includes all power to the brake, drive, control, heating or other related circuits. Verify by testing for voltage and try the operational controls to prove that all power sources are isolated.

The design of the support structure must be engineered to take the load and reaction when the maximum torque of the brake is applied. The duty cycle and all special considerations must be taken into account and an appropriate safety factor applied.

Do not alter the brake to achieve the required alignment, otherwise the integrity of the brake may be compromised and a replacement brake may not fit.

Excessive run-out or “High Spots” on a brake disc can cause localized and unnecessary heating and unequal expansion. This may result in severe and permanent damage to the brake disc. Other factors can contribute to excessive run-out which cannot be detected at low speeds, typical are bearing wear or the effect of critical shaft speed.

Aligning the calipers accurately to the disc in the plan view will maximize lining life and ensure that rated performance can be achieved with a minimum of bedding.

Chapter 4: ADJUSTMENT – Warnings and Cautions

It is the users responsibility to determine the torque required from the brake and to ensure the brake is set to provide the torque required for the application.

Chapter 6: OPERATIONAL TEST – Warnings and Cautions

Unexpected movement, dropped loads or hazardous voltage can cause burns, injury or death. Make sure the following have been tested prior to the Operational Test:

- **Torque set properly.**
- **Time Delays set properly (if supplied).**
- **Brake secure, and aligned properly.**
- **Electrical controls installed and adjusted.**

Chapter 7: INSPECTION AND MAINTENANCE – Warnings and Cautions

To allow for expansion of the working fluid, do not over fill the Actuator. Thoroughly clean-up all spills to aid in quickly detecting new leaks.

Chapter 2.0: General Description

- 2.1: The Mondel DT brake is a single caliper disc brake, consisting of spring applied, electro-hydraulic actuator released brake mechanism. See Fig. 1A and 1B.
- 2.2: The caliper unit is complete with lined pads, spring mechanism, Hy-thrust actuated release mechanism, manual release, automatic wear compensation (AA), and automatic equalization of running clearance (AE). When specifically ordered, the brake can be furnished with limit switches to indicate specific functions.
- 2.3: Operation of the brake may be enhanced to suit specific applications by the use of optional adjustable time delay valves installed within the actuator. The (S) delay is used to delay the return stroke of the actuator on de-energization and will result in a delay in the brake application. This feature can also be used to delay subsequent brakes until the first of multiple brakes has been applied. The (H) delay can be used to delay the release of the brake. A typical application would be where the drive torque will build-up gradually and brake release must be delayed to prevent "run-back".
- 2.4: The brake can be used in conjunction with a Mondel "Braketronic" controller or can be equipped with hydraulic over-rides.

Figure 1A

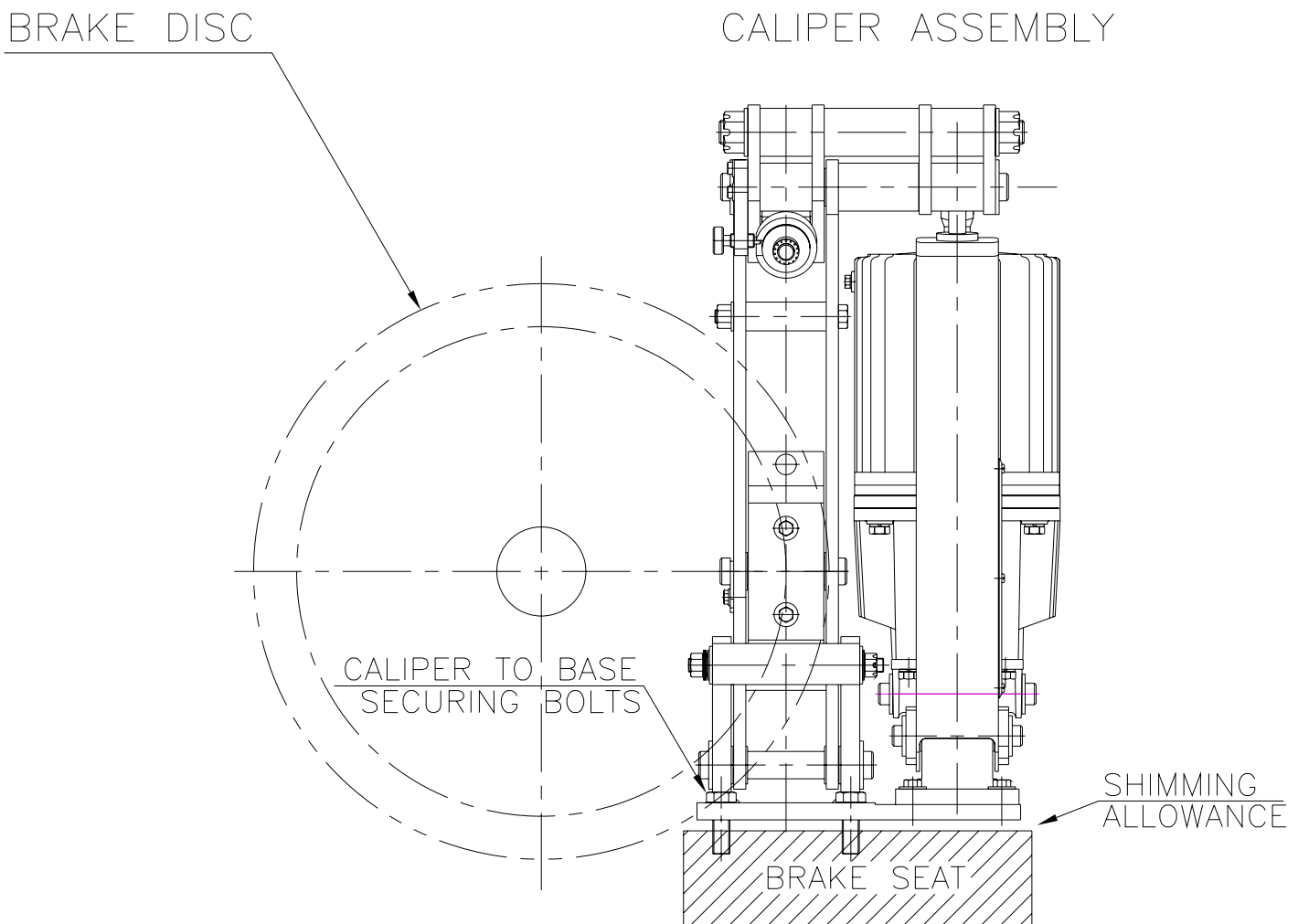
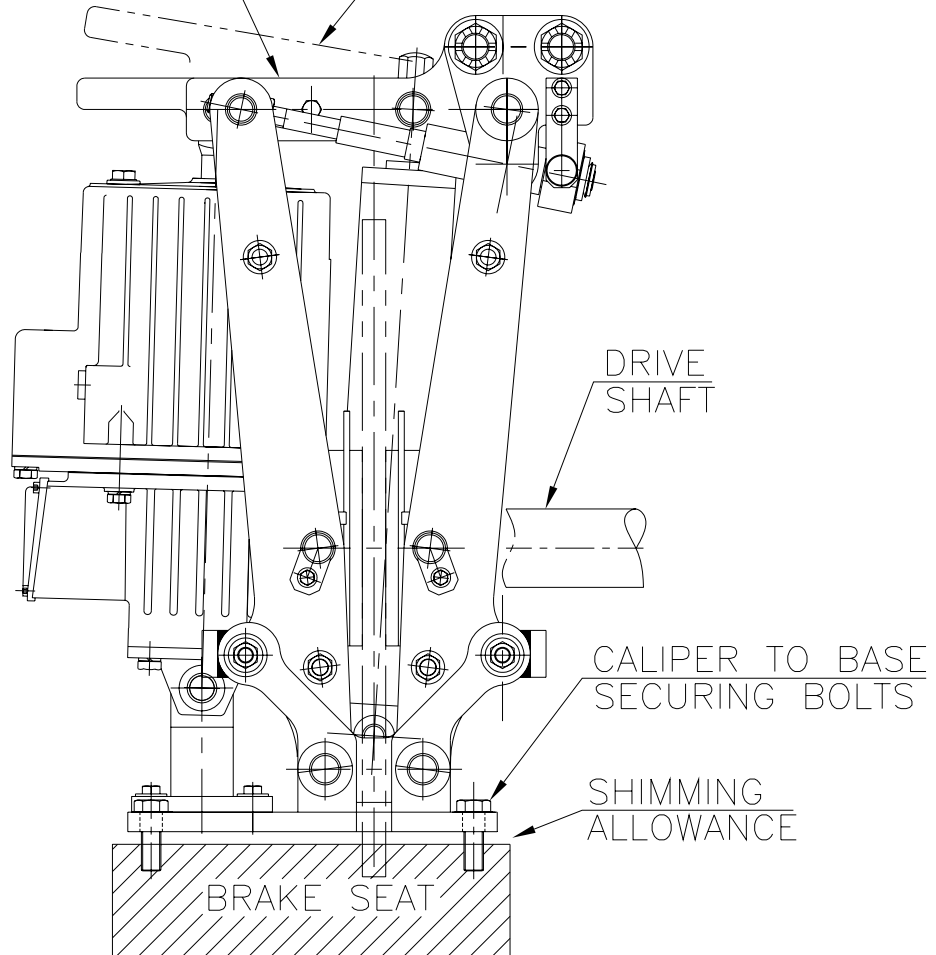

Figure 1B

LEVER IN BRAKE APPLIED POSITION LEVER IN BRAKE RELEASED POSITION



Chapter 3.0: Installation

- 3.1: Care taken when installing the brake will ensure maximum operational life.
- 3.2: After unpacking, visually inspect the brake to ensure that damage has not occurred during shipment and that there are no damaged or missing parts.
- 3.3: Prepare and align the brake support structure ready to receive the brake. Detailed dimensions are shown on the certified dimension prints. The support structure must satisfy three requirements as follows:
- 3.3.(a):** Height or elevation – the brake support structure must present a level, rigid mounting surface (brake seat) at an elevation compatible with the base of the brake, with a reasonable shimming allowance of not less than 0.030”.
- 3.3.(b):** Plan location – The bolt holes for securing the brake to the base must be positioned accurately to ensure brake alignment in both the axial and transverse directions.
- 3.3.(c):** Base Skewing – The bolt holes, for fixing the brake to the brake seat, must be positioned to ensure the brake can be installed and secured with the brake pads in full contact with the disc. Ensure there is adequate clearance between the mounting bolts and the base bolt holes, to allow the alignment of the pads to the disc. A disc brake is particularly susceptible to this type of misalignment.
- 3.4: The basic installation procedure is as follows:
- 3.4.(a):** Install the brake disc and hub assembly on the drive shaft.
- 3.4.(b):** Using a dial gauge indicator, check that disc “run-out” is within acceptable tolerance over the entire braking surface. We suggest a maximum run-out of 0.0005” per inch of disc diameter, to a maximum of 0.010”.
- 3.4.(c):** Install the caliper assembly on the equipment base. Verify the securing bolts are centered within the holes in the base and that the base is located correctly with respect to disc. Temporarily fit two of the bolts to secure the base to the equipment seat.
- 3.4.(d):** Using the manual release, open the pads to maximize clearance on the brake disc. Adjustment of the Automatic Adjustment (AA) may be necessary.
- 3.4.(e):** Apply additional shimming (if required) between the support seat and the base, as required, to raise the caliper such that the pads are centered on the horizontal axis of the disc.
- 3.4.(f):** Make sure there is sufficient margin left on the disc face on each side of pad carriers, to permit the pad carriers to move laterally within their allowable side tolerance and not overhanging the disc edge. Ensure that there is no possibility that the pads can wear and leave a ridge on the lining.
- 3.4.(g):** Ensure the axial (along the shaft) location of the brake is correct with respect to the disc. When the disc is centrally aligned with slot in the brake base, the location of the base is correct.
- 3.4.(h):** Cancel the manual release to apply the pads to the disc with at least the rated torque setting. This is to ensure that the pads are correctly aligned to the disc and will bring the brake assembly into alignment. The brake can be set and released several times to ensure alignment.
- 3.4.(i):** It should now be possible to enter all of the “caliper to base” bolts without interference with the holes. Now the caliper to base bolts can be tightened until snug.

3.4.(j): Before torquing the caliper to base securing bolts, screw in the remaining “base to brake seat” bolts. If the pad to disc alignment has not changed, torque all bolts as required and then verify all alignment criteria one more time.

3.4.(k): Preliminary operating adjustments were made at the factory on the basis of rated values or to meet specific instructions from the purchaser. The user is urged to verify his requirements and make final torque settings before putting the brake into service. See Fig. 3.

3.4.(l): Unless specifically requested and detailed on previously approved diagrams, all wiring, control logic, and sequencing of the brake(s) is the responsibility of the user. Verify that the electrical nameplate ratings are compatible with intended power source.

3.4.(m): Because the operation of the actuator is not dependent on the direction of motor rotation, the cable leads can be connected in any phase sequence. A wiring diagram is shipped inside the actuator junction box cover.

3.4.(n): When the brake has been installed as detailed in chapter 3, it is then ready for adjustment as covered in chapter 4.

Chapter 4.0: Adjustment

- 4.1: Preliminary adjustments were made at the factory, but may have been disturbed during installation. All adjustments should be verified or optimized to suit your specific requirements; this is most critical in reference to the torque setting.
- 4.2: There are two interdependent steps to achieve correct adjustment for each caliper:
- 1) Ensuring that the actuator is at the correct stroke with the brake applied.
 - 2) Setting the required torque with the brake applied.

The process of making these adjustments may affect the other, such that it may be necessary to repeat the procedure until both adjustments are in harmony and also correct on their own. The essential requirements are:

- A) The pads are in full contact with the disc.
- B) The actuator is set at the correct stroke.
- C) The spring is at the correct length for the required torque as indicated on the scale. The torque is indicated on the scale by the position of the bottom of the spring (top of the block).

Fig. 2 shows the actuator stroke divided into two zones – the “active” stroke and the “reserve” stroke and their relationship to the “brake applied” and “brake released” positions.

The “RESERVE” stroke is provided to ensure spring pressure is available to provide the intended torque when the brake is applied.

The “ACTIVE” stroke is required to ensure adequate running clearance is available when the brake is released. With the (AA) feature installed the “RESERVE” stroke is approximately 30% of the total stroke. The precise “RESERVE” stroke will be determined by the (AA) mechanism as predetermined in the factory, but provisional setting dimensions are as follows:

- 0.6” (16mm) for type Ed23/5 or Ed30/5 actuators.
- 0.7” (19mm) for type Ed50/6 through Ed301/6 actuators.

The indicated torque is only valid in the brake-applied position.

- 4.3: To set the actuator stroke and brake torque in the correct range for the automatic compensation mechanisms to work successfully, requires a provisional manual adjustment of the actuator stroke.

The actuator stroke must be correct and the brake “applied” before attempting to adjust the brake torque.

4.3.(a): Adjustments to the ACTUATOR stroke may be made as follows:

- A) Release the brake.
- B) Refer to Fig. 4.
- C) Withdraw the lock-pin (B), If the actuator is to be raised, first release the brake, rotate the assembly clockwise by means of the bronze drive shaft (C). Turn the drive shaft “C” by hand.
- D) If the actuator is to be lowered – rotate the assembly counter-clockwise by means of the bronze drive shaft “C”.
- E) Replace pin B and secure.

No tools are required to make adjustments to the AA mechanism if the brake is released before adjustments are attempted.

The drive pin (B) must be removed before any manual adjustments to actuator stroke are attempted. Failure to remove the pin before attempting manual adjustment may result in

permanent damage to the mechanism. The brake must be released before making manual adjustments to the actuator stroke.

4.3.(b): Following initial setting of the actuator stroke, the "TORQUE" setting may be made as follows:

- A) Refer to Fig. 3.
- B) Observe the present setting.
- C) If the torque setting is to be increased rotate the torque adjustment rod (D) clockwise until the top of the collar/bottom of the spring coincides with the desired torque.
- D) If the torque setting is to be decreased rotate the torque-adjusting rod (D) counter-clockwise until the top of the collar/bottom of the spring coincides with the desired torque.

Adjustments to the torque setting may affect the actuator stroke and vice versa. Any changes to one setting require verification that the other has not changed.

4.4: This brake is also equipped with AUTOMATIC EQUALIZATION OF OPERATING CLEARANCE (AE). The feature is designed to maintain the correct running clearance between the pads and disc when the brake is released. Refer to Fig. 2.

4.4.(a): When the actuator is powered the rod extends from the "BRAKE APPLIED" to the "BRAKE FULLY RELEASED". In so doing, it determines the total available running clearance. Refer to Fig. 2 and Fig. 1B.

4.4.(b): The operating clearance, resulting from the actuator stroke and the arrangement of the linkage, is biased to provide all of the available running clearance at the pad opposite the actuator.

4.4.(c): To distribute the available running clearance, so that an adequate amount is available on both pads, a mechanism is installed which limits the clearance permitted on the pad opposite the actuator. This device transfers the remainder of the available clearance to the other pad.

4.4.(d): The allowable running clearance on each pad is predetermined at the factory and cannot be changed in the field.

4.4.(e): Operation of the (AE) mechanism is dependent on the correct setting of the friction bolts Fig. 2 (F), which will maintain the running clearance regardless of lining wear. This is a factory setting and should not require adjustment.

4.5: The adjustment procedure should now be complete but as the various phases are interdependent, it is a good idea to run through them again from 4.1.

Figure 2

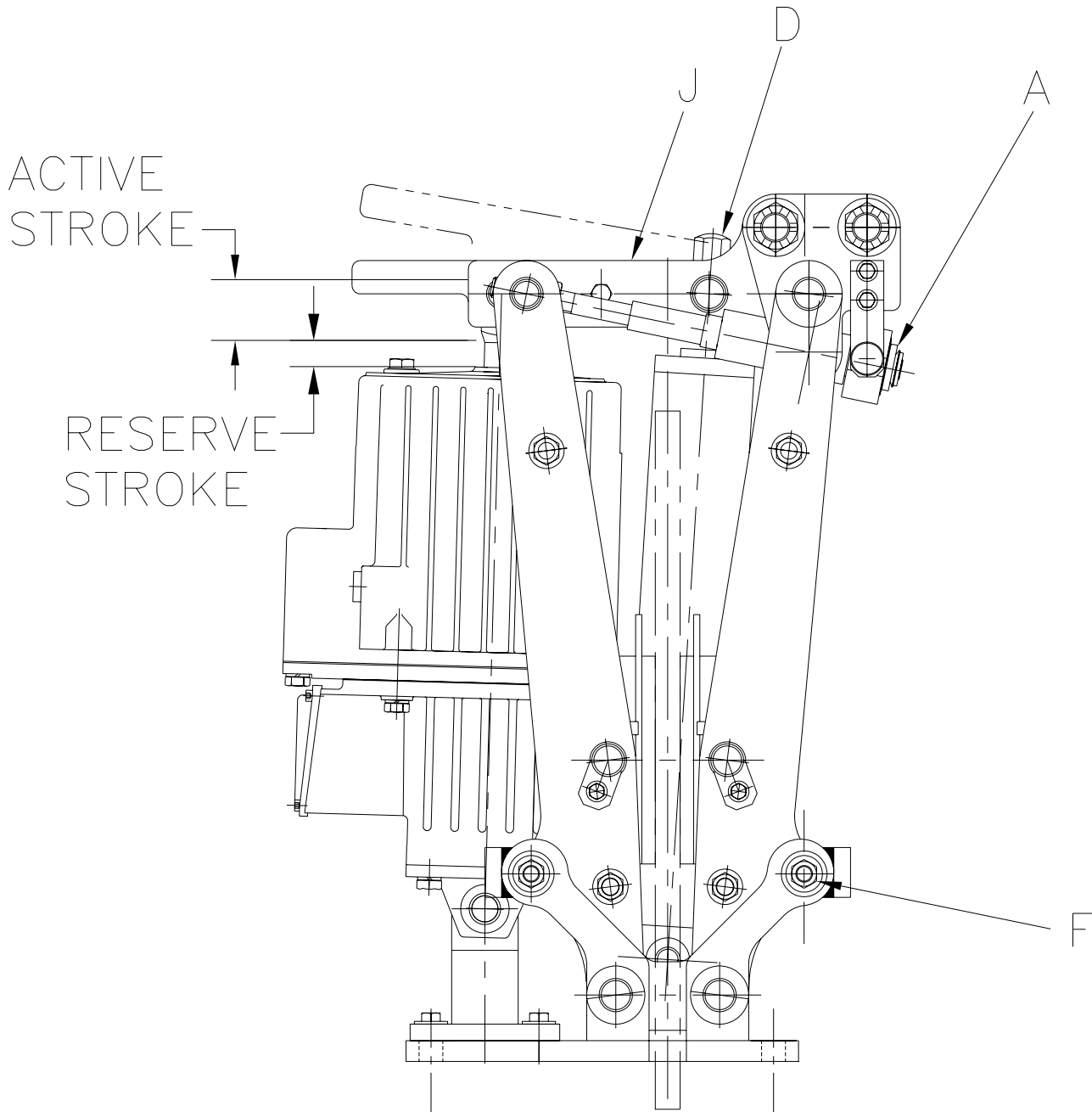

- A — STROKE ADJUSTMENT MECHANISM
- D — TORQUE ADJUSTING ROD/NUT
- F — AUTO EQUALIZATION FRICTION BOLT
- J — BRAKE LEVER

Figure 3

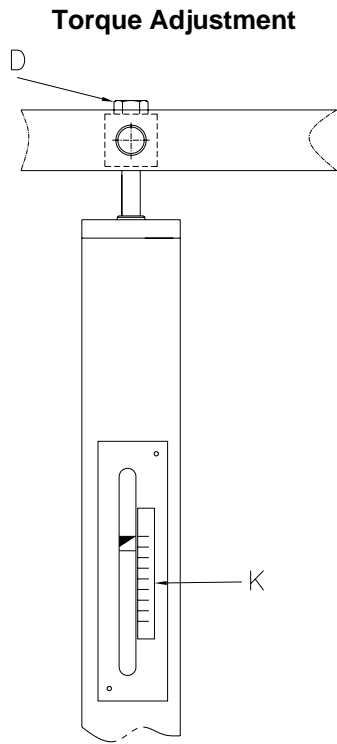
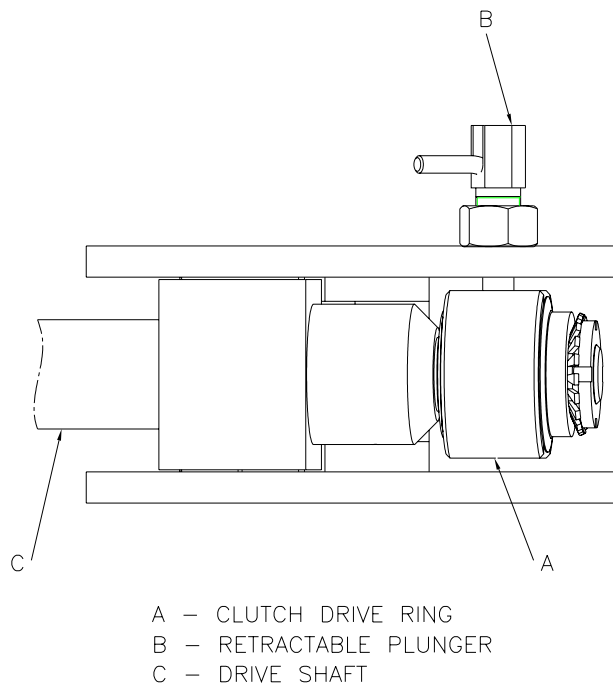

Figure 4

Lining Wear Self-Adjustment Assembly



Chapter 5.0: Actuator Delay Adjustment (Optional Feature) Refer to Fig. 5

5.1: The following describes features, which may not be installed on your brake unless specifically ordered.

5.1.(a): “S” – RETRACT DELAY VALVE – used to delay the actuator return stroke and therefore the brake application time. Turn clockwise to increase time from minimum to maximum.

5.1.(b): “H” – EXTEND DELAY VALVE – used to delay the actuator advance and therefore the brake release time. Turn clockwise to increase time from minimum to maximum.

Due to the possibility of causing unnecessary motor heating and brake wear, this feature is not recommended and is only provided on special order. Unless specific instructions are provided for adjusting this valve, we recommend that it be kept in the “fully open” position.

5.2: Adjustments are accessible through removable caps located immediately above the actuator terminal box and identified by raised letters in the casting.

5.3: After making the required adjustments, re-install the removable access caps. Do not unscrew either adjustment beyond being flush with the edge of the access hole, as this may prevent the caps from being refitted or it could cause a leak.

Figure 5

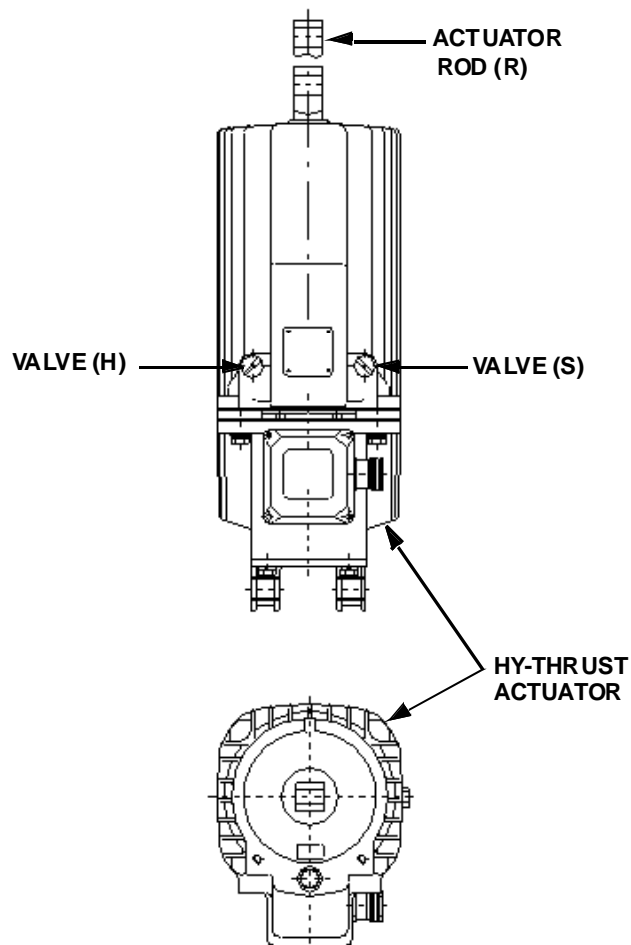

Chapter 6.0: Operational Test

- 6.1: Always perform an operational test of the brake after installation, adjustment, or repair. Conduct the test only when it is safe to do so and keep all personnel well away from any live or moving parts while testing.
- 6.2: Conduct all tests in conjunction with the instructions provided by the overall machinery manufacturer.

Chapter 7.0: Inspection and Maintenance

- 7.1: It is recommended that brake installations be inspected every 100 hours of operation or at least every month. This should include visual inspection of the entire brake for evidence of mechanical failures, misalignment, or other effects. Also check the mounting bolts to ensure that they are tight.
- 7.2: Maintenance and inspection periods depend on the operating conditions. High duty cycle applications obviously require more frequent inspections.
- 7.3: Pivot points are fitted with special bearings, which do not require lubrication.
- 7.4: In addition to the instructions listed here, follow the maintenance and safety procedures.
- 7.5: The standard actuator is supplied for a temperature range from –25C to +50C and filled with Mondel type C10 fluid. A change in working temperature range may require special fluid.
- 7.6: The actuator's oil is not subject to deterioration during normal operation.
- 7.7: Signs of fluid leakage will usually be evidence of a problem. If this occurs, it is best to purchase a replacement actuator or have it factory rebuilt.

During refilling, the actuator must be filled in the vertical position and fluid added up the overflow screw, or the filling limit of the charging connection, depending on the type of actuator. In order to prevent possible inclusions of air, run the unit through several strokes. Then check oil level again, and top up eventually. Finally, tighten charging connection and overflow screw.

When the brake is to be repainted, DO NOT PAINT – pivot points, self adjustment mechanism, pull-rod, actuator piston rod, brake drum, linings, data plates and labels. Data plates and labels must never be removed.

Chapter 8.0: Brake Pad Replacement Refer to Fig. 6

- 8.1: Brake pads must be replaced when thickness (M) is less than 0.2”.
- 8.2: Subject to the preceding warning when the pads require replacement – release the brake as follows: Ref. To Fig. 4.
- 8.2.(a):** Release retractable plunger (B).
- 8.2.(b):** Release the brake.
- 8.2.(c):** Unscrew the drive shaft (C) until the brake is completely open.
- 8.2.(d):** The self-adjustment mechanism is factory set and must not be altered.
- 8.2.(e):** Remove the securing bolts (N).
- 8.2.(f):** Remove pad backing plate (P) from above.
- 8.2.(g):** Install new pads (P) and fasten two bolts (N).
- 8.2.(h):** Re-adjust the “Actuator Stroke” as specified in chapter 4 “Adjustment”.
- 8.2.(i):** To ensure the required brake torque and performance, it is necessary to use only pads provided by Mondel.
- 8.2.(j):** The pad will require a bedding period to develop full torque.

Figure 6

