

IMPULSE[®]·P³ *Series 2*

Adjustable Frequency Crane Controls

Instruction Manual



MAGNETEK
MATERIAL HANDLING

P3S2INST-01A February 2008

Part Number: 005-1069-R1

© Copyright 2008 Electromotive Systems

All rights reserved. This notice applies to all copyrighted materials included with this product, including, but not limited to, this manual and software embodied within the product. This manual is intended for the sole use of the persons to whom it was provided, and any unauthorized distribution of the manual or dispersal of its contents is strictly forbidden. This manual may not be reproduced in whole or in part by any means whatsoever without the expressed written permission of Magnetek Material Handling Electromotive Systems.

***DANGER, WARNING, CAUTION, and NOTE* Statements**

DANGER, WARNING, CAUTION, and Note statements are used throughout this manual to emphasize important and critical information. You must read these statements to help ensure safety and to prevent product damage. The statements are defined below.



DANGER

DANGER indicates an imminently hazardous situation which, if not avoided, will result in death or serious injury. This signal word is to be limited to the most extreme situations.



WARNING

WARNING indicates a potentially hazardous situation which, if not avoided, could result in death or serious injury.



CAUTION

CAUTION indicates a potentially hazardous situation which, if not avoided, could result in minor or moderate injury. It may also be used to alert against unsafe practices.

NOTE: A *NOTE* statement is used to notify people of installation, operation, programming, or maintenance information that is important, but not hazard-related.

Disclaimer of Warranty

Magnetek Material Handling Electromotive Systems, hereafter referred to as Company, assumes no responsibility for improper programming of a drive by untrained personnel. A drive should only be programmed by a trained technician who has read and understands the contents of this manual. Improper programming of a drive can lead to unexpected, undesirable, or unsafe operation or performance of the drive. This may result in damage to equipment or personal injury. Company shall not be liable for economic loss, property damage, or other consequential damages or physical injury sustained by the purchaser or by any third party as a result of such programming. Company neither assumes nor authorizes any other person to assume for Company any other liability in connection with the sale or use of this product.



WARNING

Improper programming of a drive can lead to unexpected, undesirable, or unsafe operation or performance of the drive.

Contents

Chapter 1: Introduction

Introduction	1-3
Specifications	1-4

Chapter 2: Installation

Mounting	2-3
Mounting the Inverter	2-3
IMPULSE®•P3 Series 2 Dimensions/Heat Loss.....	2-4

Chapter 3: Wiring

IMPULSE®•P3 Series 2 Wiring Practices.....	3-3
Standard Wiring	3-4
Terminal Description	3-5
Suggested Circuit Protection Specifications and Wire Size	3-6
Grounding	3-7
Motor Thermal Overload Relay	3-7
Wiring The Control Circuit.....	3-8
Control Circuit Terminals.....	3-8
Power Circuit Terminal Arrangement	3-10
Surge Absorber Selection	3-10
Wiring Inspection	3-10
Optional Relay Outputs	3-11

Chapter 4: Keypad Operation

Using The Keypad.....	4-3
Keypad Functions	4-3
Description of Function LEDs	4-4
Status LEDs	4-5
Monitor Function	4-5

Chapter 5: Programming Basic Features

Overview	5-3
Speed Control Methods	5-3
Parameters Changed by X-Press Programming™	5-5
Preset Frequency References	5-6
Acceleration/Deceleration	5-7

Chapter 6: Programming Advanced Features

Overview	6-3
Run/Reference Source	6-3
Stopping Method.	6-4
Quick Stop™	6-4
Reverse Plug Simulation™	6-5
Swift Lift™	6-6
Volts/Hertz Setup	6-7
Programmable Digital Inputs	6-8
Programmable Digital Outputs	6-9
Miscellaneous Parameters	6-10

Chapter 7: Troubleshooting IMPULSE•P³ Series 2

Drive Faults and Indicators	7-3
Power Section Check	7-6
Power Off Checks	7-7

Appendix

Appendix A: Service	A-1
Appendix B: IMPULSE®•P3 Series 2 External Resistor Specifications	B-1
Appendix C: IMPULSE•P3 Series 2 Parameter Listing	C-1

c h a p t e r **1**

Introduction

This page intentionally left blank.

Introduction

The IMPULSE•P³ Series 2 drive is the next generation of Electromotive Systems drives, providing compact and economical crane control. This drive offers a unique option to the customer of maintaining the look and feel of the original IMPULSE•P³ drive or utilizing the expanded capabilities of the IMPULSE•P³ Series 2 drive. As a default setting from the factory, IMPULSE•P³ Series 2 programming and operation remains identical to the original IMPULSE•P³ drive, providing an easy transition from the original IMPULSE•P³ to the IMPULSE•P³ Series 2.

With the IMPULSE•P³ Series 2 drive configured to operate as an IMPULSE•P³, the familiar control capabilities of this drive are readily accessible. These include:

- Volts/Hertz Control
- X-Press Programming
- Swift-Lift
- Reverse Plug Simulation
- Quick Stop

However, by the adjustment of a single parameter, the IMPULSE•P³ Series 2 can be reconfigured to utilize many additional control features, including:

- Open-Loop Vector Control
- Micro-Speed Control
- Up to 16 Discrete Speed References
- End of Travel Limit Selection
- Load Check
- Expanded Programmable Input/Output Capabilities
- RS-485 Communications

This manual will provide support for the basic IMPULSE•P³ Series 2 drive. For information on the additional control features, please consult instruction manual 005-1070 contained on the enclosed CD.

Specifications

230V Class

Model

	2001	2003	2005	2008	2011	2017	2025	2033
Rated current (A)	1.6	3.0	5.0	8.0	11.0	17.5	25.0	33.0
Capacity (kVA)	0.6	1.1	1.9	3	4.2	6.7	9.5	13.0
Horsepower (Ref. Only)	0.25	0.5	1.0	2.0	3.0	5.0	7.5	10.0

460V Class

Model

	4001	4002	4003	4004	4008	4014	4018
Rated current (A)	1.2	1.8	3.4	4.8	8.6	14.8	18.0
Capacity (kVA)	0.9	1.4	2.6	3.7	7	11	14
Horsepower (Ref. Only)	0.5	0.75	2.0	3.0	5.0	7.5	10.0

230V, 460V Classes

Specification	Specification Value and Information for All Models
Rated Input Voltage and Frequency	3 phase, 200-230V or 380 to 460V, 50 or 60 Hz
Allowable Voltage Fluctuation	-15% to 10%
Allowable Frequency Fluctuation	±5%
Control Method	Sine wave PWM (V/f control/voltage control selectable)
Frequency Control Range	40 to 1 (V/F)
Frequency Accuracy (Temperature Change)	Digital reference: ±0.01% (-10 to +50°C) Analog reference: ±0.5% (25±10°C)
Frequency Setting Resolution	Digital reference: 0.01Hz (less than 100Hz)/0.1Hz (100Hz or more) Analog reference: 1/1000 of max. output frequency
Overload Capacity	150% rated output current for one minute.
Frequency Reference Signal	0 to 10VDC (20kΩ), 4 to 20mA (250Ω), Digital (dry circuit contact closure)
Accel/Decel Time	0.00 to 25.5 sec. (accel/decel times are independently programmed)
Braking Torque	Regenerative torque: (150% of VFD rating with braking resistor)
V/f Characteristics	Programmable
Motor Overload Protection	Electronic thermal overload relay
Instantaneous Overcurrent	Inverter output is shut off at 250% of inverter rated current
Overvoltage	Overvoltage occurs when DC Bus voltage exceeds 410V for 230V class or 820V for 460V class
Undervoltage	Undervoltage occurs when DC Bus voltage drops below 200V for 230V class or 400V for 460V class
Cooling Fin Overheat	Protected by electronic circuit
Ground Fault	Protected by electronic circuit (overcurrent level)
Power Charge Indication	ON until the DC bus voltage becomes 50V or less. RUN lamp stays ON or digital operator LED stays ON.
Ambient Temperature	14 to 122°F (-10 to +50°C)
Humidity	95% RH or less (non-condensing)
Storage Temperature	-4 to 140°F (-20 to 60°C)
Location	Indoor (free from corrosive gases or dust)
Vibration	Up to 9.8m/S ² (1G) at less than 20 Hz, up to 2m/S ² (0.2G) at less than 20 to 50Hz

c h a p t e r **2**

Installation

This page intentionally left blank.

Mounting



WARNING

- *Mount the drive on nonflammable material.*
- *The IMPULSE•P³ Series 2 drive generates heat. For the most effective cooling possible, mount vertically.*
- *When mounting units in an enclosure, install a fan or other cooling device to keep the enclosure air temperature below 122°F (50°C).*

Mounting the Inverter

Be sure the inverter is protected from the following conditions:

- Extreme cold and heat. Use only within the ambient temperature range: 14 to 122°F (-10 to +50°C).
- Rain, moisture.
- Oil sprays, splashes.
- Salt spray.
- Direct sunlight. (Avoid using outdoors).
- Corrosive gases (e.g. sulfurous gas) or liquids.
- Dust or metallic particles in the air.
- Physical shock, vibration.
- Magnetic noise. (Example: welding machines, power devices, etc.)
- High humidity.
- Radioactive substances.
- Combustibles: thinner, solvents, etc.

IMPULSE®•P3 Series 2 Dimensions/Heat Loss

230 Volt

Model	Overall Dimensions in inches and (mm)			Mounting Dimensions in inches and (mm)			Wt Lbs/(kg)	Total Heat Loss	
	W	H	D	W1	H1	d		(W)	Fig.
2001-P3S2	2.68 (68)	5.04 (128)	2.99 (76)	2.20 (56)	4.65 (118)	M4	1.55 (0.7)	18.0	2-1
2003-P3S2	2.68 (68)	5.04 (128)	4.25 (108)	2.20 (56)	4.65 (118)	M4	2.20 (1.0)	28.1	2-1
2005-P3S2	2.68 (68)	5.04 (128)	5.04 (128)	2.20 (56)	4.65 (118)	M4	2.65 (1.2)	45.1	2-1
2008-P3S2	4.25 (108)	5.04 (128)	5.16 (131)	3.78 (96)	4.65 (118)	M4	3.53 (1.6)	72.8	2-2
2011-P3S2	4.25 (108)	5.04 (128)	5.51 (140)	3.78 (96)	4.65 (118)	M4	3.75 (1.7)	94.8	2-2
2017-P3S2	5.51 (140)	5.04 (128)	5.63 (143)	5.04 (128)	4.65 (118)	M4	5.30 (2.4)	149.1	2-2
2025-P3S2	7.09 (180)	10.24 (260)	6.70 (170)	6.46 (164)	9.61 (244)	M5	10.14 (4.6)	256.5	2-3
2033-P3S2	7.09 (180)	10.24 (260)	6.70 (170)	6.46 (164)	9.61 (244)	M5	10.58 (4.8)	308.9	2-3

460 Volt

Model	Overall Dimensions in inches and (mm)			Mounting Dimensions in inches and (mm)			Wt Lbs/(kg)	Total Heat Loss	
	W	H	D	W1	H1	d		(W)	Fig.
4001-P3S2	4.25 (108)	5.04 (128)	3.62 (92)	3.78 (96)	4.65 (118)	M4	2.65 (1.2)	23.1	2-2
4002-P3S2	4.25 (108)	5.04 (128)	4.33 (110)	3.78 (96)	4.65 (118)	M4	2.65 (1.2)	30.1	2-2
4003-P3S2	4.25 (108)	5.04 (128)	5.51 (140)	3.78 (96)	4.65 (118)	M4	3.75 (1.7)	54.9	2-2
4004-P3S2	4.25 (108)	5.04 (128)	6.14 (156)	3.78 (96)	4.65 (118)	M4	3.75 (1.7)	75.7	2-2
4008-P3S2	5.51 (140)	5.04 (128)	5.63 (143)	5.04 (128)	4.65 (118)	M4	5.30 (2.4)	117.9	2-2
4014-P3S2	7.09 (180)	10.24 (260)	6.70 (170)	6.46 (164)	9.61 (244)	M5	10.14 (4.6)	256.5	2-3
4018-P3S2	7.09 (180)	10.24 (260)	6.70 (170)	6.46 (164)	9.61 (244)	M5	10.58 (4.8)	308.9	2-3

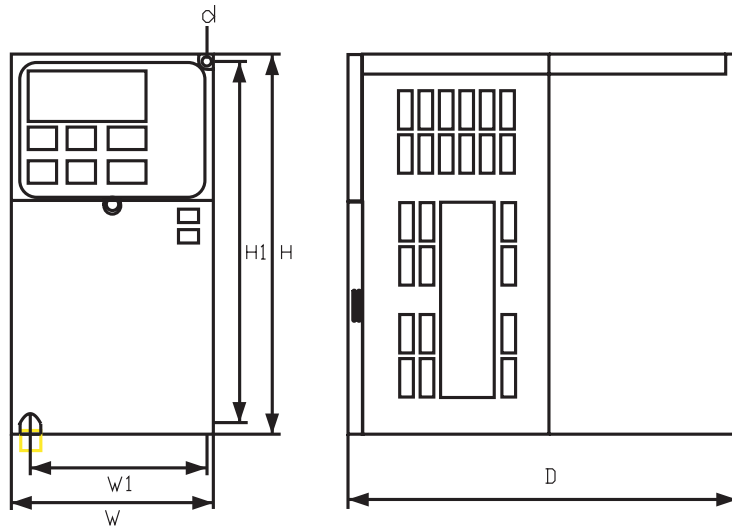

Figure 2-1

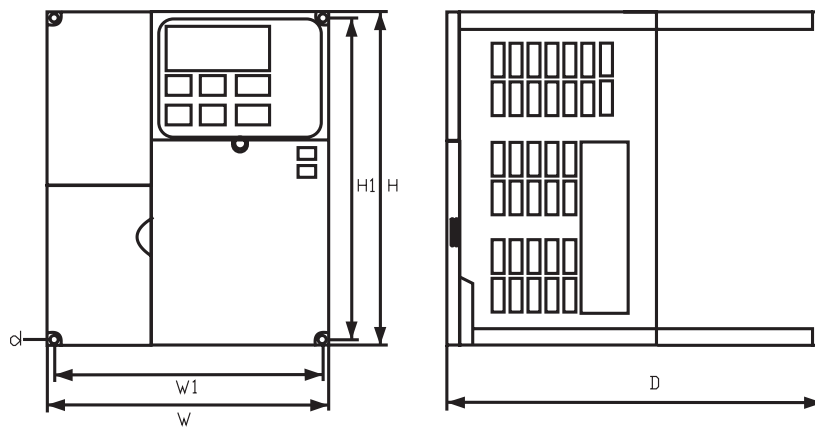

Figure 2-2

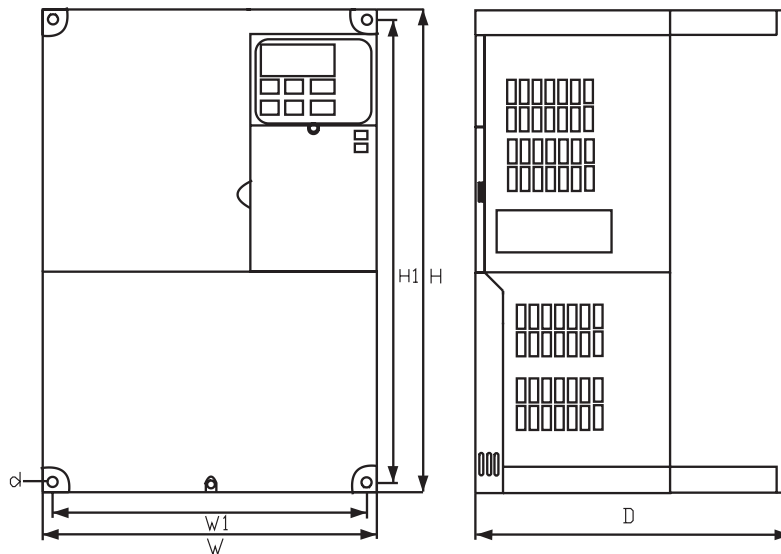

Figure 2-3

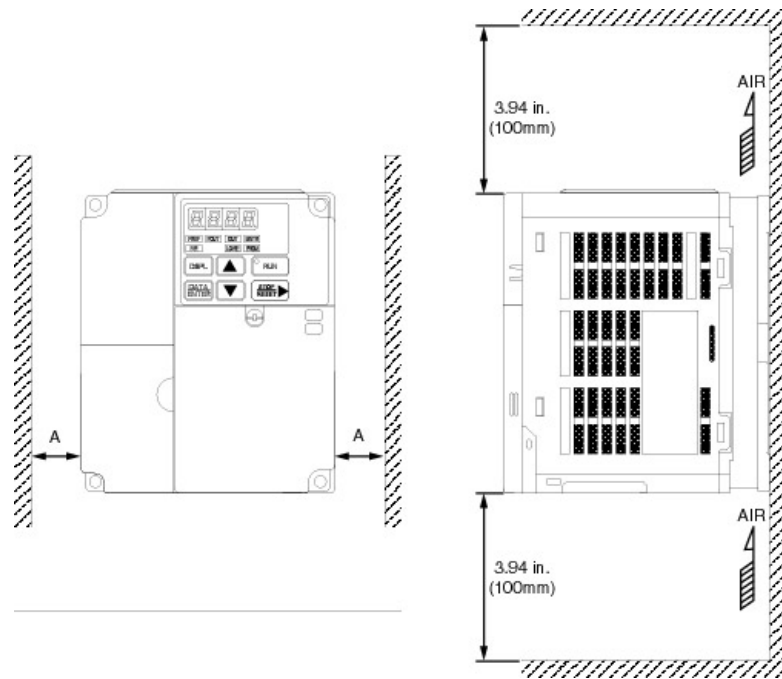

Figure 2-4: Mounting Clearances

Reference the table below for the recommended clearances to use when mounting the drive.

Voltage	Max. Applicable Motor Output HP	A
230V 3-Phase 460V 3-Phase	Less than 5 HP	More than 1.18in. (30mm)
230V 3-Phase 460V 3-Phase	7.5 HP 10 HP	More than 1.97in. (50mm)

c h a p t e r **3**

Wiring

This page intentionally left blank.

IMPULSE®•P³ Series 2 Wiring Practices



WARNING

Before you wire the drive, review the following practices to ensure that your system is wired properly.

- Connect the incoming three-phase AC source to terminals R/L1, S/L2, T/L3.
- Connect the Motor leads to terminals U/T1, V/T2, W/T3.
- Ensure that the drive-to-motor wiring distance is less than 150 ft. unless appropriate reactors and/or filters are used.
- On external user input devices, use hard contact inputs rather than solid-state inputs.
- If the user input device is a solid state device or a PLC TRIAC output, use a 5K Ω , 10W resistor in parallel with the signal and X2.
- If the power source is 500 kVA or greater, or more than 10 times the inverter kVA rating, ensure that there is at least 3 percent impedance between the power source and the drive input. To accomplish this, you can install a DC reactor between inverter terminals +1 and +2, or use an AC line reactor on the input of the drive. If you don't provide enough impedance, excessive peak currents could damage the input power supply circuit.
- Comply with "Suggested Circuit Protection Specifications and Wire Size."
- Use time delay fuses, which are sized at 150% of drive's continuous-rated current, for drive input protection.
- Use appropriate R-C or MOV type surge absorbers across the coil of all contactors and relays in the system. Failure to do so could result in noise-related, nuisance fault incidents.
- Ensure that the drive is solidly grounded to the enclosure sub-panel and that all ground leads are as short as possible. (Refer to Grounding on page 3-7).
- Use external dynamic braking resistors for all applications.
- Do not ground the drive with any large-current machines.
- Before using any welding or high-current equipment near the drive, disconnect all wires from the drive.
- Do not use output contactors between the drive and the motor.
- Do not let the wiring leads come in contact with the drive enclosure.
- Do not connect power factor correction capacitors to the drive input or output.
- Hard-wire the drive and motor (e.g., festoon cable). Do not use sliding collector bars.
- Before turning on the drive, check the output circuit (U/T1, V/T2 and W/T3) for possible short circuits and ground faults.
- Use shielded cable for all low-level DC speed reference signals (0 to 10VDC, 4 to 20 mA). Ground the shield only at the drive side.

Failure to observe these warnings may result in equipment damage.

Standard Wiring

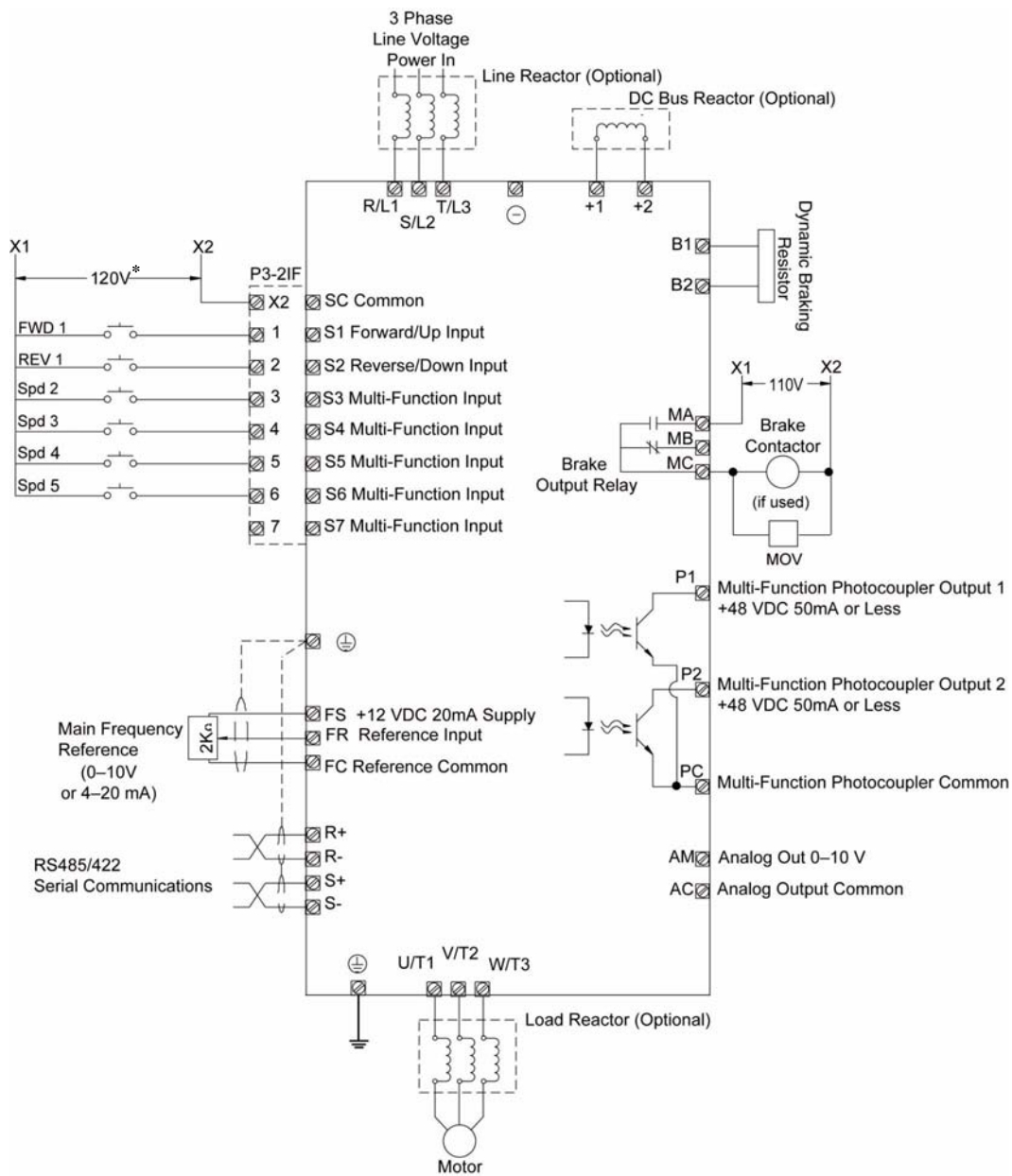

* A 120VAC interface is standard. 24VAC and 48VAC interface cards are optional and must be specified.

Figure 3-1: Standard Wiring Diagram

Terminal Description

Type	Terminal	Name	Function (Signal Level)				
Main Circuit	R/L1, S/L2, T/L3	AC power supply input	AC power supply input				
	U/T1, V/T2, W/T3	Inverter output	Inverter output				
	B1, B2	Braking resistor connection	Braking resistor connection				
	+2, +1	DC reactor connection	When connecting optional DC reactor, remove the main circuit short-circuit bar between +2 and +1.				
	+1, (-)	DC power supply input	DC power supply input (+1: positive -: negative)				
	⊕	Grounding	Ground to local grounding codes				
Control Circuit	Sequence	S1	Multi-function input selection 1	FWD run when closed, stop when open	Photo-coupler insulation 24VDC, 8mA.		
		S2	Multi-function input selection 2	REV run when closed, stop when open			
		S3	Multi-function input selection 3	Inputs are programmable			
		S4	Multi-function input selection 4				
		S5	Multi-function input selection 5				
		S6	Multi-function input selection 6				
		S7	Multi-function input selection 7				
		SC	Multi-function input selection common	Common for control signal			
	Input	Frequency reference	FS	Power for frequency setting	+12V (permissible current 20mA max.)		
			FR	Master speed frequency reference	0 to +10VDC (20kΩ) or 4 to 20mA (250Ω)		
			FC	Frequency reference common	0V		
	Output	Multi-function contact output	MA	NO contact output	Factory setting: brake output	Contact capability 250VAC 1A or less, 30VDC 1A or less	
			MB	NC contact output			
			MC	Contact output common			
			P1	Photo-coupler output 1	Outputs are programmable		Photo-coupler output +48VDC, 50mA or less
			P2	Photo-coupler output 2			
			PC	Photo-coupler output common			
		AM	Analog monitor output	Factory setting: Output frequency 0 to +10V	+10VDC, 2mA or less, 8-bit resolution		
	AC	Analog monitor common	0V				
	Communication Circuit Terminal	MEMOBUS communications	R+	Communications input (+)	MEMOBUS communication Run through RS-485 or RS-422.	RS-485/422 MEMOBUS protocol, 19.2 kps max.	
			R-	Communications input (-)			
			S+	Communications output (+)			
			S-	Communications output (-)			

Suggested Circuit Protection Specifications and Wire Size

In order to comply with most safety standards, some circuit protective device should be used between the incoming three-phase power supply and the IMPULSE•P³ Series 2 drive. This device can be thermal, magnetic, or molded-case breakers (MCCB); or time delay type fuses such as “CCMR” or “J.”



CAUTION:

The following guidelines are only suggested values. Always conform to NEC and your local electrical codes and wiring practices.

Model #	Rated Current(A)		Time Delay	Inverse Time	Wiring Size (AWG)		
	Drive	InputFuse	Input Fuse Class	Molded/Case Circuit Breaker	Power Circuit Wiring	Control Wiring	Ground Copper
230VClass							
2001-P3S2	1.6	3	CC	10	14	18/16	14
2003-P3S2	3	5	CC	10	14	18/16	14
2005-P3S2	5	8	CC	10	14	18/16	14
2008-P3S2	8	15	CC	15	14	18/16	14
2011-P3S2	11	20	CC	20	12	18/16	10
2017-P3S2	17.5	30	J	35	10	18/16	10
2025-P3S2	25	40	J	50	8	18/16	10
2033-P3S2	33	50	J	70	6	18/16	8
460VClass							
4001-P3S2	1.2	2	CC	10	14	18/16	14
4002-P3S2	1.8	3	CC	10	14	18/16	14
4003-P3S2	3.4	6	CC	10	14	18/16	14
4004-P3S2	4.8	8	CC	10	14	18/16	14
4008-P3S2	8.6	15	CC	15	14	18/16	14
4014-P3S2	14.8	25	CC	30	10	18/16	10
4018-P3S2	18.0	30	J	40	10	18/16	10

Grounding

(Use ground terminal )

Make sure to ground the ground terminal according to the local grounding code. Never ground the IMPULSE•P³ Series 2 in common with welding machines, motors, or other electrical equipment.

When several IMPULSE•P³ Series 2 units are used side by side, ground each unit as shown in examples. Do not loop the ground wires.

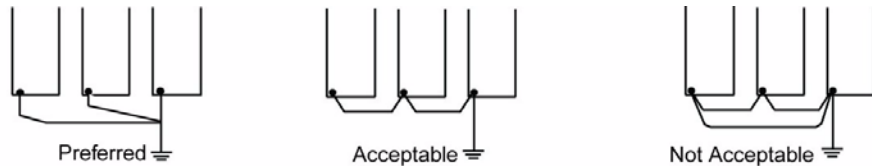

Grounding of three IMPULSE•P³ Series 2 Drives



Motor Thermal Overload Relay

(When Used)

To prevent the motor from overheating, IMPULSE•P³ Series 2 can be programmed to provide motor overload protection.

When multiple motors are being operated in parallel using a single IMPULSE•P³ Series 2, separate thermal overload relays may be used to provide motor overload protection for each motor. In this case, programmable, electronic motor overload protection may be disabled.

A thermal overload relay is not required when the motor(s) has thermal detector(s) embedded in its windings. Because operating fan-cooled motors at low speeds may overheat the motor (even at rated current), the use of thermal detectors in the motor is recommended when using IMPULSE•P³ Series 2 with fan cooled motors. Although this is not the case with non-ventilated type motors, thermal detectors will always provide a level of protection not available with conventional thermal overload relays. It is recommended that programmable overload protection be enabled when motor thermal detectors are provided.

Wiring The Control Circuit

Control Circuit Terminals

The IMPULSE•P³ Series 2 is shipped with a 120V control interface card, allowing direct connection of 120V user input devices. The interface card connects to drive terminals S1-S7 and SC, and the user input device then connects to terminals 1-7 and X2 on the interface card. Terminals 1 and 2 are used for the forward (up) and reverse (down) run commands, and the remaining terminals are programmable for speed control or other functions.

Due to variations in the physical dimensions of the drives with different ratings, two different interface cards have been developed.

Drive Model Number	Interface Card	Drive Model Number	Interface Card
2001-P3S2	P3-2IF2	4001-P3S2	P3-2IF1
2003-P3S2	P3-2IF2	4002-P3S2	P3-2IF1
2005-P3S2	P3-2IF2	4003-P3S2	P3-2IF1
2008-P3S2	P3-2IF1	4004-P3S2	P3-2IF1
2011-P3S2	P3-2IF1	4008-P3S2	P3-2IF1
2017-P3S2	P3-2IF1	4014-P3S2	P3-2IF2
2025-P3S2	P3-2IF2	4018-P3S2	P3-2IF2
2033-P3S2	P3-2IF2		

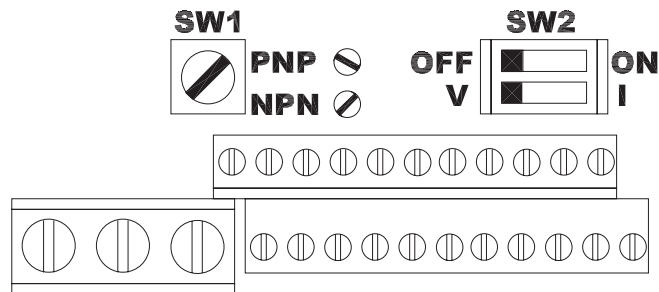

Switch (SW1) can be changed according to the sequence input signal (S1 to S7) polarity.

NOTE: Switch (SW1) must remain at NPN setting for use with 120V interface cards.

Switch (SW2) sets the mode of speed reference input on terminals FR and FC.

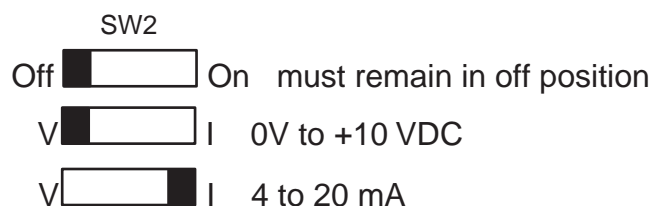

The IMPULSE•P3 Series 2 is shipped with the interface card already attached. The figures below are provided in the event the board needs to be reattached.

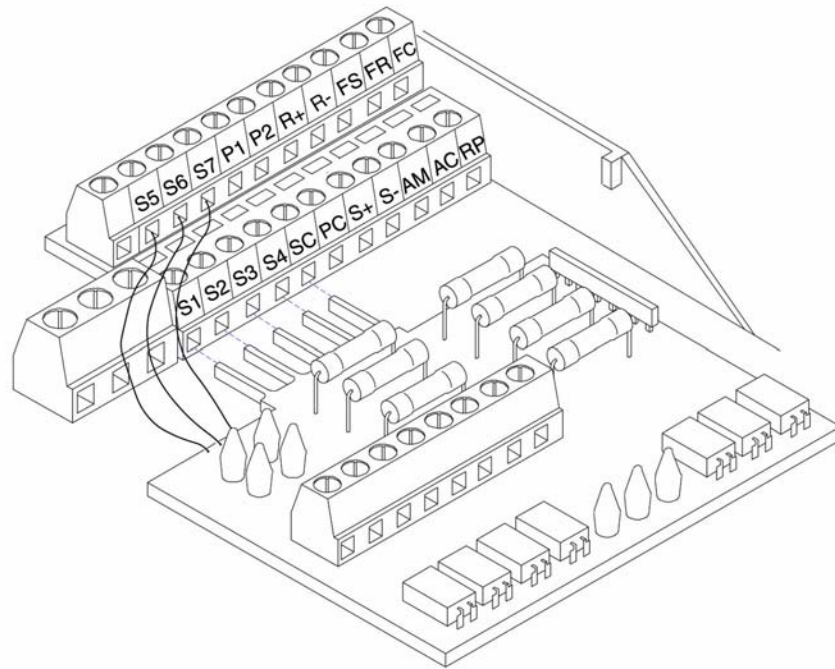

Figure 3-2: P3-2IF2 Interface Card

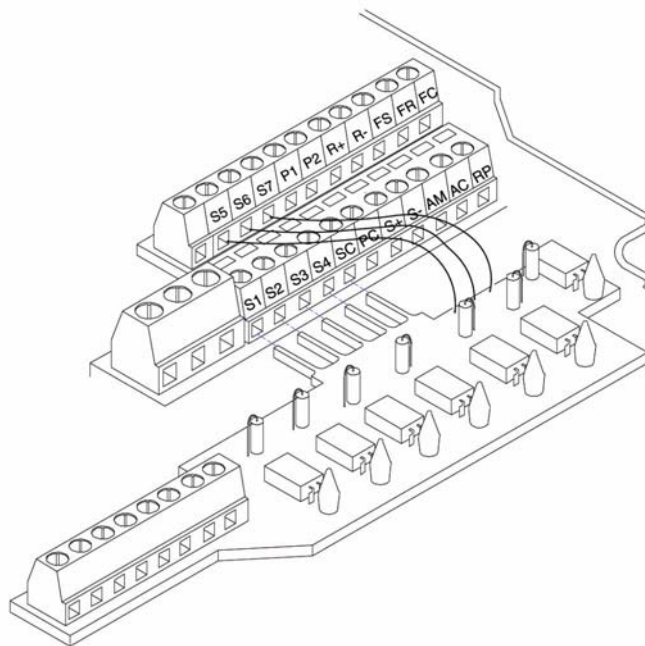
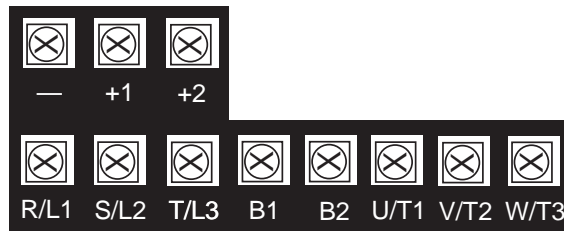

Figure 3-3: P3-2IF1 Interface Card

Power Circuit Terminal Arrangement



Models 2001-P3S2, 2003-P3S2 and 2005-P3S2



Models 2008-P3S2, 2011-P3S2, 4001-P3S2 thru 4004-P3S2



Models 2017-P3S2, 4008-P3S2



Models 2025-P3S2, 2033-P3S2, 4014-P3S2 and 4018-P3S2

Figure 3-4: Power Circuit Terminal Arrangement

Surge Absorber Selection

Install appropriate R-C or MOV type surge suppressor across the coils of any contactors installed in the drive's control panel enclosure.

Wiring Inspection

After wiring is complete, check the following:

- Wiring is properly connected.
- Wire clippings or screws are not left inside the unit.
- Screws are securely tightened
- Bare wires in the terminal do not come in contact with other terminals.

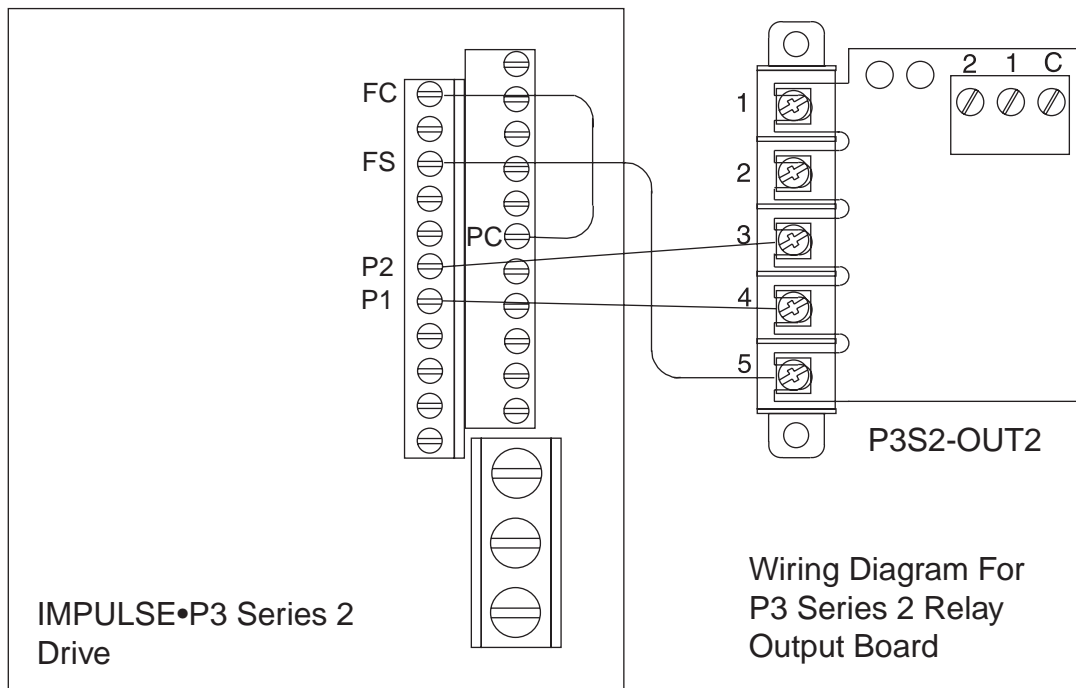

Figure 3-5: P3S2-OUT2 Interface Card

Optional Relay Outputs

Interface Card P3S2-OUT2 provides two 240 VAC, 1.5 Amp rated solid-state relay outputs. Each relay is independently programmable. Constant n036 and n037 (see page 6-9 for programming) will configure these digital outputs.

This page intentionally left blank.

c h a p t e r **4**

Keypad Operation

This page intentionally left blank.

Using The Keypad

All functions of the drive are accessed using the keypad. The operator can enter information into the drive memory to configure the drive's application by using the Function LEDs.

Keypad Functions

The keypad has a 4-digit LED display. Both numeric and alpha-numeric data can appear on the display.

Indicators and keys on the keypad are described in Figure 4-1.

NOTE: The STOP key is always active and will cause any run command to come to an immediate stop.

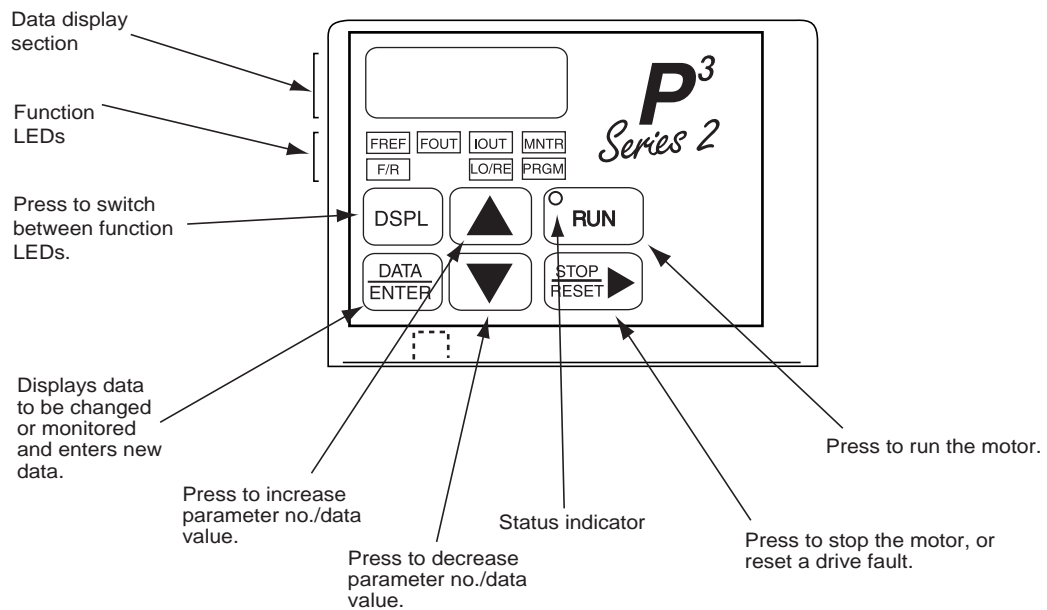

Figure 4-1: IMPULSE•P³ Series 2 Keypad

Description of Function LEDs

By pressing the DSPL key on the keypad, the operator can step to each of the seven Function LEDs and its associated display/setting function:

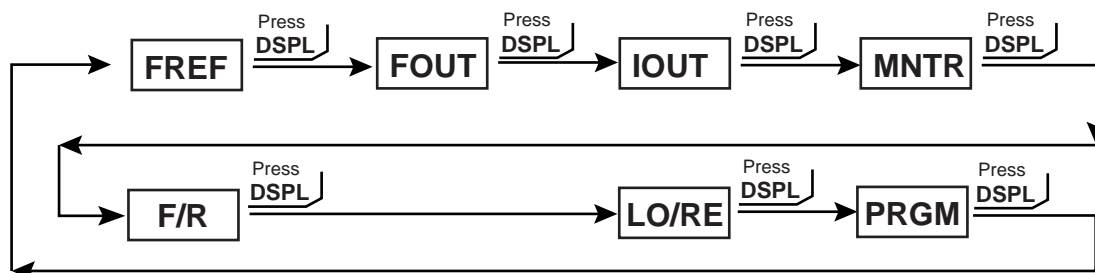

Figure 4-2: Function LEDs

FREF	<p>Frequency Reference Setting Sets/Displays the drive operation speed (Hz).</p>
FOUT	<p>Output Frequency Monitor Displays the output frequency (Hz) at which the drive is currently operating. This is a monitor only function; the operator cannot change the displayed value by use of the keypad.</p>
IOUT	<p>Output Current Monitor Displays the level of output current (Amps) that the drive is currently producing. This is a monitor only function; the operator cannot change the displayed value by use of the keypad.</p>
MNTR	<p>Monitor Selection Pressing ENTER allows access to the various Monitor parameters, <i>U1-01</i> through <i>U1-11</i>. These are monitor-only functions; the operator cannot change the displayed value. Accessible during run command. See page 4-5. for complete listing of all monitor parameters.</p>
F/R	<p>FWD/REV Run Selection Sets the rotation direction of the motor when a Run command is given by the Digital Operator keypad. Display of <i>For</i>=forward run, <i>rev</i>=reverse run.</p>
LO/RE	<p>Local/Remote Selection In advanced mode, this toggles between the Local (keypad) and Remote modes of operation. This affects both the start/stop functions, as well as the frequency reference.</p>
PRGM	<p>Parameter Programming Selects or reads data using parameter number (<i>nXXX</i>). Data is displayed by pressing the ENTER key, and can be changed by pressing the “up arrow” or “down arrow” keys. Any changes can be saved by again pressing the ENTER key. Pressing the DSPL key exits the programming mode.</p>

Status LEDs

There are two indicator LEDs on the front of the drive. The drive status is indicated by various combinations of ON, Blinking and Off conditions of these two LEDs:

	(Green) ○	(Red) ○
Condition	RUN	ALARM
Operation Ready (during stop) Ramp To Stop (during decel)	Blinking Long Blinking	Off Off
Normal Operation (running) Alarm	On Blinking or ON	Off Blinking
Fault	Off	On

For details of how the status indicator LEDs function during a drive fault, refer to the “Troubleshooting” section.

Monitor Function

When using the Monitor Function, a variety of information can be displayed on the keypad. The Up/Down arrow keys scroll through each of the U-XX parameters list below. Pressing the Data/Enter key will cause the display to show the data in the monitor parameter currently displayed.

Parameter U-	Monitored Item	Display Example
01	Frequency reference (Hz)	60.0
02	Output frequency(Hz)	60.0
03	Output current (A)	12.5
04	AC Output Voltage (V) RMS	230
05	DC Bus Voltage (VDC)	325
06	Input Terminal Status	(See diagram 1 below)
07	Output Terminal Status	(See diagram 2 below)
08	Motor Torque (%) (Open loop vector only)	72
09	Fault record (Press the up or down arrow keys to view the last four faults)	oC
10	Software number XXXX	5171
11	Output Power (KW)	99.9
15-18	Not used	–

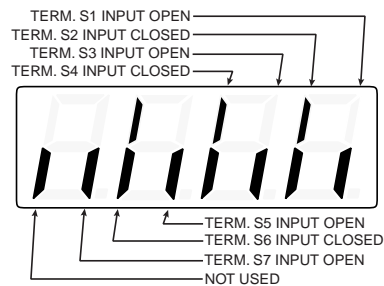

Diagram 1

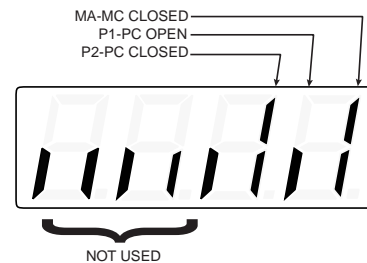

Diagram 2

Figure 4-3: Monitor Function

This page is intentionally left blank.

c h a p t e r **5**

Programming Basic Features

This page intentionally left blank.

Overview

This chapter explains the programming basics in order to get up and running with minimum effort. A description of basic parameters necessary to begin operation of the drive are included.

NOTE: This chapter describes programming options available when n060=0.

Speed Control Methods

X-Press Programming™ allows for quick setup of the drive. By setting a single parameter, the drive settings can be configured for many common methods of operation. If discrete inputs and speed references are desired, one of the Multi-Step Speed Control methods should be selected. The IMPULSE•P³ Series 2 provides 2-Step, 3-Step or 5-Step Multi-Step control methods. A sample timing diagram for 5-Step control is shown below. For each input that is energized, the drive begins to operate at the corresponding frequency set in parameter n003–n007. If 2 or 3-Step is desired, then the frequency reference for the 2nd or 3rd step will be set at the maximum desired speed of operation.

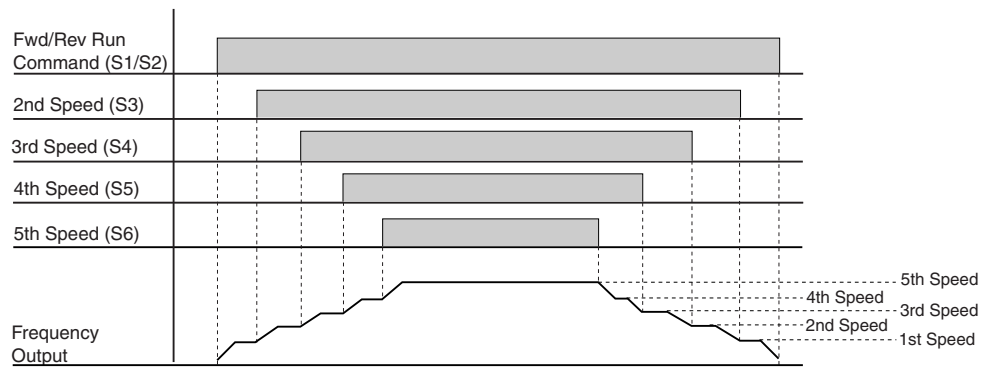

Figure 5-1: 5-Speed Multi-Step Speed Control

In addition to discrete speed control, true infinitely variable speed control can be configured. The IMPULSE•P³ Series 2 has two ways in which infinitely variable control can be configured, 2-Step Infinitely Variable and 3-Step Infinitely Variable control. Sample timing diagrams for both methods are given.

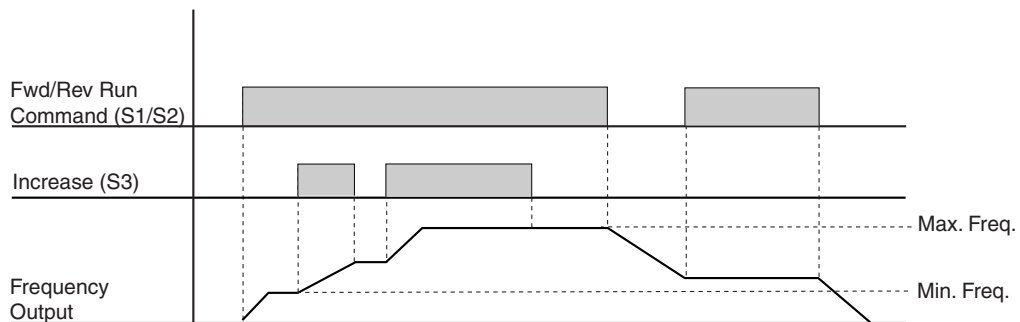

Figure 5-2: 2-Step Infinitely Variable Speed Control

NOTE: Shown with stopping method set to ramp to stop. If the stopping method is base-block to stop (as in hoisting applications), the frequency output is immediately set to zero and the brake is set when the run command is removed rather than ramping down to minimum frequency.

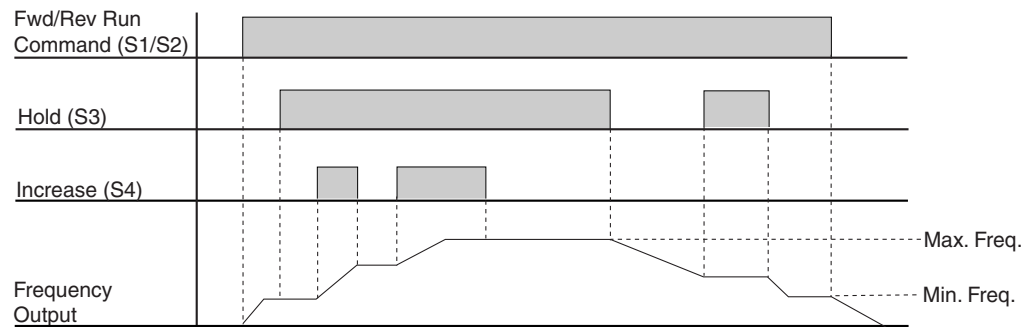

Figure 5-3: 3-Step Infinitely Variable Speed Control

Parameter	Name	Data	Function	Initial Value	Data Range
n000	X-Press Programming	00	Initialize for traverse/two-speed multi-step control		
		01	Initialize for traverse/three-speed multi-step control		
		02	Initialize for traverse/five-speed multi-step control		
		03	Initialize for traverse/two-step infinitely variable control		
		04	Initialize for traverse/three-step infinitely variable control		
		05	Initialize for hoist/two-speed multi-step control	06	00-0A
		06	Initialize for hoist/three-speed multi-step control		
		07	Initialize for hoist/five-speed multi-speed control		
		08	Initialize for hoist/two-step infinitely variable control		
		09	Initialize for hoist/three-step infinitely variable control		
		0A	Initialize parameters to default settings (n000-n053)		
20	Initialize all paramters to default settings				
n001	Motor Rated Current	–	Set to motor name plate current	kVA Depend ent	0-120% Rated Current
n002	Password	00	Reading Parameters n000-n014 is enabled, setting is disabled (except n002)		
		01	Reading Parameters n000-n014 is enabled, setting parameters n000-n002 is enabled		
		02	Reading Parameters n000-n060 is enabled, setting parameters n000-n014 is enabled		
		09 Or 0A	Reading and setting all parameters are enabled		

NOTE: Set n002 = 09 to unlock and make parameter changes. Password will lock again when the drive is powered down.

Parameters Changed by X-Press Programming™

Table 5-1: n060=0: P³ Emulation and n000=0-4: Traverse Motion

Parameter	Setting/Description	n003	n004	n005	n006	n007	n008	n009	n013	n032	n033	n034	n047	n049	n052
		Freq. Ref 1	Freq. Ref. 2	Freq. Ref. 3	Freq. Ref. 4	Freq. Ref. 5	Accel Time 1	Decel Time 1	Stop Method	S3 Function	S4 Function	S5 Function	Mid V Output Freq.	Min. V Output Freq.	S6 Function
n000	0 2-Speed Multi-Step	6.0	60.0			60.0	5.0	3.0	x0xx	00	05	10	16.1/32.2	9.2/18.4	0F
	1 3-Speed Multi-Step	6.0	30.0	60.0		60.0	5.0	3.0	x0xx	00	01	05	16.1/32.2	9.2/18.4	0F
	2 5-Speed Multi-Step	6.0	15.0	30.0	45.0	60.0	5.0	3.0	x0xx	00	01	02	16.1/32.2	9.2/18.4	20
	3 2-Step Infinitely Variable	6.0				60.0	5.0	3.0	x0xx	04	05	10	16.1/32.2	9.2/18.4	0F
	4 3-Step Infinitely Variable	6.0				60.0	5.0	3.0	x0xx	03	04	05	16.1/32.2	9.2/18.4	0F

Table 5-2: n060=0: P³ Emulation and n000=5-9: Hoist Motion

Parameter	Setting/Description	n003	n004	n005	n006	n007	n008	n009	n013	n032	n033	n034	n047	n049	n052
		Freq. Ref 1	Freq. Ref. 2	Freq. Ref. 3	Freq. Ref. 4	Freq. Ref. 5	Accel Time 1	Decel Time 1	Stop Method	S3 Function	S4 Function	S5 Function	Mid V Output Freq.	Min. V Output Freq.	S6 Function
n000	5 2-Speed Multi-Step	6.0	60.0			60.0	5.0	3.0	x1xx	00	05	10	19.5/39	12.6/25.2	0F
	6 3-Speed Multi-Step	6.0	30.0	60.0		60.0	5.0	3.0	x1xx	00	01	05	19.5/39	12.6/25.2	0F
	7 5-Speed Multi-Step	6.0	15.0	30.0	45.0	60.0	5.0	3.0	x1xx	00	01	02	19.5/39	12.6/25.2	20
	8 2-Step Infinitely Variable	6.0				60.0	5.0	3.0	x1xx	04	05	10	19.5/39	12.6/25.2	0F
	9 3-Step Infinitely Variable	6.0				60.0	5.0	3.0	x1xx	03	04	05	19.5/39	12.6/25.2	0F

Shaded cell indicates this parameter will not change if this setting is selected

For binary data, "X" indicates no change for this bit

For n047 and n049, left side indicates 230V setting and right side indicates 460V setting.

Preset Frequency References

When utilizing X-Press Programming to set up multi-step control for discrete frequency references, the desired reference is programmed into n003-n007.

Constant	Name	Bit	Data/ Function	Function	Initial Value	Data Range
n003	Freq. Ref. 1/ Lower Limit	–	–	Setting Unit = 0.1 Hz	*	1.5~150.0
n004	Freq. Ref. 2	–	–	Setting Unit = 0.1 Hz	*	1.5~150.0
n005	Freq. Ref. 3	–	–	Setting Unit = 1 Hz	*	2~150
n006	Freq. Ref. 4	–	–	Setting Unit = 1 Hz	*	2~150
n007	Freq. Ref. 5/ Upper Limit			Setting Unit = 1 Hz	*	2~150

* Initial value is determined by X-Press Programming tables 5-1 and 5-2.

Acceleration/Deceleration

The acceleration time is the time needed to accelerate from “0” Hz up to maximum frequency, n043. The deceleration time is the time needed to decelerate from the maximum output frequency, n043 to 0 Hz. The default set of accel/decel times used is n008/n009. There is also a second set of accel/decel times, n011/n012, which may be activated by using a programmable digital input. In order to provide smooth transition during accel/decel, s-curves are provided. The length of the s-curve is adjusted by bits 3 and 4 of n016.

Constant	Name	Bit	Data/ Function	Function	Initial Value	Data Range
n008	Acceleration Time 1	–	–	Setting Unit = 0.1 Sec.	*	0.0~25.5
n009	Deceleration Time 1	–	–	Setting Unit = 0.1 Sec.	*	0.0~25.5
n011	Acceleration Time 2	–	–	Setting Unit = 0.1 Sec.	2.5	0.0~25.5
n012	Deceleration Time 2	–	–	Setting Unit = 0.1 Sec.	1.5	0.0~25.5
n016	Selection of Other Functions	4,3	00	S-Curve not provided	0101 (Binary)	0000~1111 (Binary)
			10	S-Curve is 0.2 seconds		
			01	S-Curve is 0.5 seconds		
			11	S-Curve is 1.0 seconds		

* Initial value is determined by X-Press Programming tables 5-1 and 5-2.

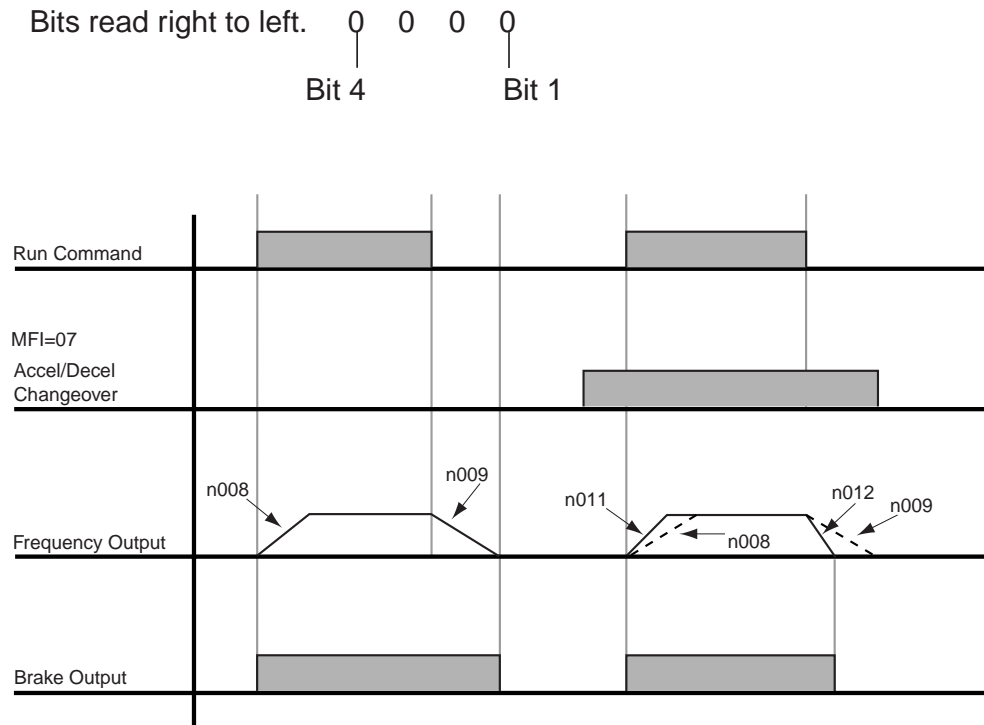

NOTE: Stopping method is set to “Ramp to Stop”

Figure 5-4: Normal Accel/Decel Time and Multiple Accel/Decel Changeover

This page intentionally left blank.

c h a p t e r **6**

**Programming Advanced
Features**

This page intentionally left blank.

Overview

The IMPULSE•P³ Series 2 provides several more advanced features, some of which are common to variable frequency drives and others that have been specifically designed to improve the performance of this drive in the overhead material handling industry. This chapter includes the programming details for these features.

Run/Reference Source

The drive's default setting is to receive both its run and reference from the digital inputs. The drive may also be configured to receive a reference from analog input or from the keypad. In addition, the run command may also be configured to be generated from the keypad. If the drive is run from the keypad, the RUN button must be maintained. When the RUN button is released, the drive will come to an immediate stop.



WARNING

Because of the additional potential hazards that are introduced when any drive is operated locally, we advise you to avoid operating it this way. If you do operate the drive locally, be aware that the crane or hoist will move when you press the RUN button. If you have questions contact Electromotive Systems.

Constant	Name	Bit	Data/ Function	Function	Initial Value	Data Range
n013	Run Signal Selection 1	1	0	Master reference is analog**	0101*	0000~ 1111
			1	Master reference is digital		
		2	0	Run by external terminal		
			1	Run by digital keypad		
n024	Analog Frequency Reference Gain	–	–	Setting Unit = 0.01	1.00	0~ 2.55
n025	Analog Frequency Reference Bias	–	–	Setting Unit = 0.01	0.00	-1.00~ 1.00
n050	Analog Frequency Reference Signal Selection See page 3-8 for proper setting of SW2	1	0	0-10V (FR-FC)**	0000 (Binary)	0000~ 1111
			1	4-20mA (FR-FC)**		
		2	0	No Function		
			1	No Function		
		3	0	No Function		
			1	No Function		
		4	0	No Function		
			1	No Function		
n051	Analog Frequency Reference Filter Time Constant	–	–	Setting Unit = 0.01sec.	0.1	0.00~ 0.200

* Initial value is determined by X-Press Programming tables 5-1 and 5-2.

**See Page 3-8 for the proper setting of SW2 if an analog frequency reference is used. Digital reference has priority over analog reference. When n013 bit 1 is set to 0 the selected frequency reference will be overridden by a digital reference input.

Bits read right to left. 0 0 0 0
 | | | |
 Bit 4 Bit 1

Stopping Method

The IMPULSE•P³ Series 2 allows stopping by either utilizing a deceleration ramp or by an immediate stop. Care should be taken when using the deceleration ramp to ensure adequate stopping distance based on the programmed deceleration time. The stopping method is configured in n013.

Additionally, DC injection is also utilized at the end of a deceleration ramp to bring the motor to a complete stop before the brake is set. DC injection is configured using n026-n028.

Constant	Name	Bit	Data/ Function	Function	Initial Value	Data Range
n013	Stopping Method	3	0	Deceleration to Stop	0101*	0000~ 1111
			1	Base Block to Stop		
n026	DC Injection Braking Current	–	–	Setting Unit - 1%	50%	0~ 100%
n027	DC Injection Time at Stop	–	–	Setting Unit - 0.1 Sec.	0.5 Sec.	0.0~ 1.2 Sec.
n028	DC Injection Decay Time	–	–	Setting Unit = 0.01 Sec.	0.00 Sec.	0.00~ 1.20 Sec.

* Initial value is determined by X-Press Programming tables 5-1 and 5-2.

Quick Stop™

This function is designed to provide an alternate deceleration time when the run command is removed. If n010 bit 1 is set to a 1, the drive will decelerate according to n012 rather than using n009.

Constant	Name	Bit	Data/ Function	Function	Initial Value	Data Range
n010	Special Functions	1	0	Quick Stop Disabled	0000 (Binary)	0000~ 0111 (Binary)
			1	Quick Stop Enabled (Stopping by n012 time)		
n012	Deceleration Time 2	–	–	Setting Unit = 0.1 Sec.	1.5	0.0~25.5

Bits read right to left. 0 0 0 0
 | | | |
 Bit 4 Bit 1

Swift Lift™

Swift Lift provides the ability to operate at increased speeds under light load or no load conditions. This feature will compare the torque required to raise a load against a preset value. If the torque is less than the preset value, the drive will be allowed to increase the frequency reference to the designated over-speed value.

There are two methods that may be utilized to enable Swift Lift. First, Swift Lift can be enabled to automatically occur whenever the load permits by setting bit 3 of n010. Swift Lift may also be enabled externally. In this case, bit 3 of n010 should be zero. Manual enabling of Swift Lift requires one of the programmable inputs to be set to 05. If the input is on, the torque comparison occurs and it is possible to run at the Swift Lift frequency. If the input is off, the drive will never perform the torque comparison and only run up to the maximum frequency.

Enable Swift Lift Function:

1. Set n010 bit 3 to enable the **Swift Lift Function**.
2. Set n020 to determine the maximum output frequency during **Swift Lift**.
3. Set n021 and n022 to determine the maximum output current level to enable **Swift Lift**.
4. Set n043 to maximum output frequency during **Swift Lift** (n020).

Analog Frequency Reference

5. If the system is using an analog frequency reference, the following formula is used to adjust n024 (analog frequency reference gain).

$$n024 = 60 \text{ Hz} \times 100/n043$$



WARNING

Motors and drive machinery must be capable of operating above the motor base speed. Consult the motor/gearbox/hoist manufacturer before enabling Swift Lift function. Failure to observe this warning may result in damage to equipment and possible injury or death to personnel.

Constant	Name	Bit	Data/ Function	Function	Initial Value	Data Range
n010	Special Functions	3	0	Swift Lift Disabled	0000 (Binary)	0000~ 0111 (Binary)
			1	Swift Lift Enabled		
n020	Swift Lift Frequency	–	–	Setting Unit = 1 Hz	60 Hz	2~ 150 Hz
n021	Swift Lift Enabling Current at Forward	–	–	Setting Unit = 1% Inverter Rated Current NOTE: Setting of 0% disables Swift Lift in this direction	50%	0~100%
n022	Swift Lift Enabling Current at Reverse	–	–	Setting Unit = 1% Inverter Rated Current NOTE: Setting of 0% disables Swift Lift in this direction	0%	0~100%
n023	Swift Lift Delay Time at Threshold Speed	–	–	Setting Unit = 0.1 Sec.	0.2	0.1~25.5 Sec.
n024	Analog Frequency Reference Gain	–	–	Setting Unit = 0.01	1.00	0~ 2.55

Bits read right to left. 0 0 0 0
 | |
 Bit 4 Bit 1

Volts/Hertz Setup

Maintaining the correct relationship between the output voltage and frequency is critical for proper operation of the motor. Having the correct V/f pattern allows the drive to provide full load torque across its entire operating range and prevents excessive current and heating in the motor.

If more starting torque is required, the V/f pattern may be increased to help increase the torque. Care must be taken to avoid raising the voltage too high, as this will result in higher motor currents and heating. The default V/f patterns for both the traverse and hoisting applications are listed, as well as a suggested pattern for use when increased starting torque is required.

Application	Max. Volts	Max. Freq.	Mid Freq.	Mid Volts	Min Freq.	Min. Volts
	n044	n045	n046	n047	n048	n049
Traverse	460	60	3.0	32.2	1.5	18.4
Hoist	460	60	3.0	37.0	1.5	25.2
High Torque	460	60	3.0	43.7	1.5	29.9

NOTE: The values listed are for 460V operation. All voltages in the table must be divided by 2 for 230V operation.

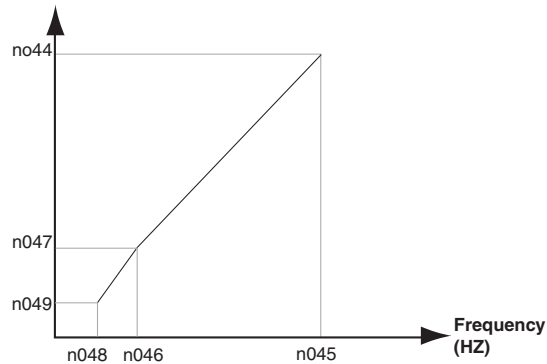

Figure 6-2: Volts/Hertz Setup

Constant	Name	Bit	Data/ Function	Function	Initial Value	Data Range
n043	Max. Output Frequency	–	–	Setting Unit = 0.1 Hz	60.0	50.0~ 150.0 Hz
n044	Max. Output Voltage	–	–	Setting Unit = 0.1 V	230/ 460V	0.1~255.0V or 0.1~510.0V
n045	Frequency at Max. Voltage	–	–	Setting Unit = 0.1 Hz	60.0	0.2~150.0 Hz
n046	Frequency at Mid. Voltage	–	–	Setting Unit = 0.1 Hz	3.0 Hz	0.1~ 149.9 Hz
n047	Mid. Output Voltage	–	–	Setting Unit = 0.1V	*	0.1~255.0V or 0.1~510.0V
n048	Frequency at Min. Voltage	–	–	Setting Unit = 0.1 Hz	1.5 Hz	0.1~10.0 Hz
n049	Min. Output Voltage	–	–	Setting Unit = 0.1 V	*	0.1~50.0V or 0.1~100.0V

* Initial value is determined by X-Press Programming tables 5-1 and 5-2.

Programmable Digital Inputs

The IMPULSE•P³ Series 2 has five programmable digital inputs that may be configured as desired. The functions of the inputs are programmed using n032, n033, n034, n052 and n053. A list of the functions and a short description are provided.

NOTE: These terminals are configured by X-Press Programming when n000 is changed.

Constant	Name	Data/ Settings	Data/ Function	Function	Initial Value	Data Range	
n032	Terminal S3 Select	00	–	Multi-Step Speed Control-Speed 2			
		01	–	Multi-Step Speed Control-Speed 3			
		02	–	Multi-Step Speed Control-Speed 4			
		03	–	Speed Hold (For 3 Step Infinitely Variable Speed Mode)			
		04	–	Accel Command (for 2 or 3 Step Infinitely Variable Mode)			
		05	–	Swift Lift Enable			
		06	–	Fault Reset (N/O–Action at Closed)			
		07	–	Accel/Decel Time Changeover			00~20
		08	–	External Base Block Fault (N/O–Action at Closed)			
		09	–	External Base Block Fault (N/C–Action at Open)			
		0A	–	DC Injection Command			
		0B~0F	–	No Function			
		10~1F	–	External Fault (N/O–Action at Closed)			
20	–	Multi-Step Speed Control-Speed 5					
n033	Terminal S4 Select (S4 Function)			Menu same as n032	*	00~20	
n034	Terminal S5 Select (S5 Function)			Menu same as n032	*	00~20	
n052	Terminal S6 Select (S6 Function)			Menu same as n032	*	00~20	
n053	Terminal S7 Select (S7 Function)			Menu same as n032	0F	00~20	

* Initial value is determined by X-Press Programming tables 5-1 and 5-2.

Programmable Digital Input Descriptions:

Function	Description
Multi-Step Speed Control	These inputs are used to command the different speed references in 2, 3 and 5 step multi-step speed control methods.
Speed Hold	This input maintains the current frequency reference when operating in 3 step infinitely variable speed control.
Accel Command	This input is used to accelerate toward maximum speed in both 2 and 3 step infinitely variable speed control methods.
Accel/Decel Changeover	This input will cause the 2nd Accel/Decel times to be used when the input is on, and the 1st Accel/Decel times to be used when the input is off.
Swift-Lift Enable	This input allows the Swift-Lift feature to only be activated when desired. To activate Swift-Lift via this input, the automatic Swift-Lift enable needs to be off, the Swift-Lift parameters need to be properly programmed (n020-n023) and then the input must be energized.
External Fault	An input may be programmed to generate a fault or alarm in the drive.
Base Block	An input may be programmed to generate a base block condition in the drive. In addition the input may be either normally open or normally closed.

Programmable Digital Outputs

The IMPULSE•P³ Series 2 has three programmable digital outputs that may be used to monitor many conditions in the drive. These outputs are programmed using n035–n037 and a list of what can be monitored is provided.

Constant	Name	Data/ Settings	Data/ Function	Function	Initial Value	Data Range
n035	Contact Output Terminals MA, MB, MC	0		Brake Output (Running)	0	0~5
		1		Zero Speed		
		2		Frequency Detection 1 (\geq n038)		
		3		Frequency Detection 2 (\leq n038)		
		4		Overtorque Detection (contact closed when detected)		
		5		Fault Output		
n036	Multi-Function Output 1 Terminal P1			Menu same as n035	4	0~5
n037	Multi-Function Output 2 Terminal P2			Menu same as n035	5	0~5

Miscellaneous Parameters

Constant	Name	Bit/ Settings	Data/ Settings	Function	Initial Value	Data Range
n014	Electronic Thermal Motor Protection	1	0	Electronic thermal protection enabled	0100	0000-1111
			1	Electronic thermal protection disabled		
		2	0	Standard motor simulation		
			1	Inverter motor simulation		
		3	0	Thermal time constant is for continuous motor		
			1	Thermal time constant is for short time rated motor		
		4	0	OL1 Fault is reset after RUN command is removed		
			1	OL1 Fault is not reset automatically		
n015	Auto-Reset Limit			Sets the number of reset attempts Setting of 0 disables auto-reset	3	0-10
n016	Selection of Other Function	1	0	Stall prevention during decel enabled	0101	0000-1111
			1	Stall prevention during decel disabled		
		2	0	Analog output = frequency output		
			1	Analog output = current output		
		4, 3	00	S-curve not provided		
			10	S-curve is 0.2 seconds		
			01	S-curve is 0.5 seconds		
n017	Overtorque Detection	1	0	Overtorque detection disabled	0000	0000-1111
			1	Overtorque detection is enabled		
		2	0	Detected only during constant running		
			1	Detected under all conditions		
		3	0	Operation continues after overtorque detection (Alarm)		
			1	Base block at overtorque detection (fault)		
		4	0	No Function		
			1	No Function		
n018	Overtorque Detection Level			Setting Unit = 1%	100%	10-150%
n019	Overtorque Detection Delay Time			Setting Unit = 0.1 Sec.	0.2 Sec	0.0-1.2
n029	Torque Compensation Gain			Setting Unit = 0.1	1.0	0.0-2.5
n030	Stall Prevention at Accel			Setting Unit = 1% Note: Setting of 200% disables Stall Prevention	170%	30-200%
n031	Stall Prevention During Run			Setting Unit = 1% Note: Setting of 200% disables Stall Prevention	160%	30-200%
n038	Frequency Detection Level			Setting Unit = 0.1 Hz	0.0	0.0-150

Constant	Name	Bit/ Settings	Data/ Settings	Function	Initial Value	Data Range
n039	Carrier Frequency			Setting Unit = 1 (1 = 2.5 kHz)	1.0	1-4
n040	Analog Monitor Gain			Setting Unit = 0.01	1.0	0.01-2.0
n041	Fault History			First Digit=Fault Number Digits 2~4=Fault Code ("..." = No Fault)		
n042	Software Number			Last 4 Digits of Software Number are Displayed		
n060	Parameter Switchover	0		P3 Emulation	0	0,1
		1		P3 Series 2 Advanced (See manual 005-1070)		

Bits read right to left. 0 0 0 0
 | | | |
 Bit 4 Bit 1

This page intentionally left blank.

c h a p t e r **7**

Troubleshooting
IMPULSE•P³ Series 2

This page intentionally left blank.

Drive Faults and Indicators

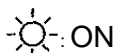

ON







: Blinking

● : OFF

Alarm Display and Contents

Alarm Display		Explanation	Causes and Corrective Actions
Digital Operator	RUN (Green) ALARM (Red)		
Uv Blinking		UV (DC bus under voltage) Main circuit DC voltage drops below the low-voltage detection level while the inverter output is OFF. 230V: Occurs at DC bus voltage below approx. 200V 460V: Occurs at DC bus voltage below approx. 400V.	Check the following: Line voltage Branch fuses Terminal screws are securely tightened.
ov Blinking		OV (DC bus overvoltage) Main circuit DC voltage exceeds the over voltage detection level while the inverter output is OFF. Detection level: 230V class: Approx 410V or more 460V class: Approx 820V or more	Check the line voltage.
oH Blinking		OH (Cooling fin overheat) Intake air temperature rises while the inverter output is OFF.	Check the intake air temperature.
oH3 Blinking		OH3(Inverter overheating pre-alarm)	
oL3 Blinking		OL 3 (Over torque detection) Motor current exceeded the preset value in parameter n018.	Reduce the load and expand the accel/decel time.
bb Blinking		BB (External baseblock) Baseblock command at multi-function input terminal is active. The inverter output is shut OFF (motor coasting). Fault is cleared when input is removed.	Check the external circuit. Check proper programming of n032-n034, n052 or n053.
EF Blinking		EF (Simultaneous FWD/REV run commands) When FWD and REV run commands are simultaneously input for over 500ms, the inverter stops according to parameter n013.	Check the control input wiring.
STP Blinking	or 	STP (Operator function stop) STOP/RESET button on keypad is pressed during running. The inverter stops according to parameter n013.	Open FWD/REV command of control circuit terminals.
FAn Blinking		FAN (Cooling fan fault) Cooling fan is locked.	Check the following: Cooling fan is jammed Cooling fan wiring is not connected.

Fault Display		Explanation	Causes and Corrective Actions
Digital Operator	RUN (Green) ALARM (Red)		
<i>oC</i>		OC (Over current) Inverter output current momentarily exceeds approx. 250% of rated current.	Check for short circuit in the motor wiring Extend the accel/decel time (parameters n008, n009, n010 and n012) Do not start the motor during coasting
<i>SC</i>		SC (Short-circuit) The Inverter output or load was short circuited.	Disconnect the motor from the inverter. Check for short circuit in the motor wiring.
<i>GF</i>		GF (Ground Fault) The ground fault current at the Inverter output exceeded approximately 50% of the Inverter rated output current.	Disconnect the motor from the inverter. Check for short circuit in the motor wiring.
<i>oV</i>		OV (DC bus overvoltage) Main circuit DC voltage exceeds the detection level because of excessive regenerative energy from the motor. Detection level: 230V: Approx. 410V or more 460V: Approx. 820V or more	Insufficient decel time (parameters n009 and n012). Lowering of heavy load causing excessive regeneration. Incorrect braking resistor.
<i>Uv1</i>		UV1 (DC bus undervoltage) Main circuit DC voltage drops below the low voltage detection level while the inverter output is ON. 230V: Below approx. 200V 460V: Below approx. 400V	Check for the following: Open phase of line voltage Occurrence of momentary power loss Open branch fuse(s) Terminal screws are securely tightened.

Fault Display		Explanation	Causes and Corrective Actions
Digital Operator	RUN (Green) ALARM (Red)		
<i>Uv2</i>		UV2 (Control power supply fault) Voltage fault of control power supply is detected.	Cycle power. If the fault remains, replace the inverter.
<i>PF</i>		PF (Input Phase Loss)	An open-phase occurred in the input power supply. A momentary power loss occurred. The voltage fluctuations in the input power supply are too large. The line voltage balance is bad.
<i>LF</i>	● 	LF Output Phase Loss An open-phase occurred at the Inverter output.	There is a broken wire in the output cable. There is a broken wire in the motor winding. The output terminals are loose.
<i>oH</i>		OH (Cooling fin overheat) Temperature rise because of inverter overload operation or intake air temperature rise.	Excessive Duty Cycle Improper V/f pattern setting Insufficient accel time if the fault occurs during acceleration Intake air temperature exceeding 122°F (50°C) Cooling fan has failed
<i>oL1</i>	●	OL1 (Motor overload) Motor overload by electronic thermal overload protection.	Check the load size or V/f pattern setting (parameters n043-n049) Set the motor rated current shown on the nameplate by parameter n001.
<i>oL2</i>	● 	OL2 (Inverter overload) Inverter output exceeded the inverter overload level.	Check the load size or V/f pattern setting (parameters n043-n049) Check the inverter capacity
<i>oL3</i>		OL3 (Over torque detection) Inverter output current exceeded the preset value in parameter n018. When over torque is detected, inverter performs operation according to the setting of parameter n017.	Check for proper programming of n018. Reduce the load.
<i>EFx</i>		EF1-7: External fault input command from corresponding input terminal S1-S7	Check the external circuit
<i>F0x</i>	● 	CPF-00 Inverter cannot communicate with the keypad for 5 sec. or more when power is turned ON. CPF-04 EEPROM fault of inverter control circuit is detected. CPF-05 A/D converter fault is detected CPF-07 Operator control circuit (EEPROM or A/D converter) fault	Cycle power after checking the keypad is securely mounted. Re-initialize drive by setting n000 to 0A. If the fault remains, replace the keypad or inverter.

Power Section Check



WARNING

Do NOT touch any circuit components while AC main power is on or immediately after the main AC power is disconnected from the unit. You must wait until the red “CHARGE” lamp is extinguished. It may take as long as 10 minutes for the charge on the main DC bus capacitors to drop to a safe level. Failure to adhere to this warning could result in serious injury.

Power Off Checks

To perform a power section check, remove the drive's main and control wiring from the terminal strips. Obtain reading as specified in the table below and ensure that the reading falls within the normal reading range.

Test equipment - Analog Ohmmeter set R x 1 scale or digital multimeter set to the diode check.

Device	VOM (on RX1 Scale)		Normal Reading (Analog Meter)	Normal Reading (Digital Meter)
	Positive Lead	Negative Lead		
Input Rectifier Bridge *1	L1	+	7-100Ω	Approximately 0.5 V
	L2	+		
	L3	+		
	-	L1		
	-	L2		
	-	L3		
	L1	-	Infinite Ω	OL Displayed
	L2	-		
	L3	-		
	+	L1		
	+	L2		
	+	L3		
Bus Capacitors	+	-	Observe gradually increasing resistance	Observe gradually increasing voltage to OL
Pre-charge Resistor *4	B1	+	100 Ω or less	-
Output Transistors *2 *3	T1	+	7-100 Ω	Approximately 0.5V
	T2	+		
	T3	+		
	-	T1		
	-	T2		
	-	T3		
	T1	-	Infinite Ω	OL Displayed
	T2	-		
	T3	-		
	+	T1		
	+	T2		
	+	T3		
Braking Diode	B2	B1	10 Ω	0.5 V
	B1	B2	Infinite Ω	OL Displayed

*1. "+" could be any one of two (+) terminals which are labeled as ⊕1 and ⊕2.

*2. If the bus fuse is blown you must install a jumper across the fuse terminals to get accurate resistance measurements.

*3. If the pre-charge resistor is open, you will read infinite Ω between + and any output terminal unless you install a temporary jumper across the resistor.

*4. If using a digital multimeter, set to the ohms scale to measure the pre-charge resistor.

This page intentionally left blank.

A p p e n d i x

This page intentionally left blank.

Appendix A: Service

This chapter includes information pertaining to on-call service, drive identification, troubleshooting, and warranty. Before you install, troubleshoot, or service the drive, we highly recommend that you read this entire chapter. Doing this will help assure quick service response, minimize your on-site repair costs, and reduce crane downtime.

Your *IMPULSE•P³* Series 2 drive includes a two-year warranty from date of shipment. The warranty is described in detail later in this chapter.

On-Call Service

If you ever require our assistance, contact us at (866) 624-7378; our fax number is (800) 298-3508. Technical support is available 24 hours a day, seven days a week, and 365 days a year. If necessary, we can arrange to have a Service Technician visit your site to evaluate the situation.

Identifying Your Drive

If you ever have to contact Electromotive Systems about your drive, first determine the model and serial numbers of your drive by looking at the nameplate. This nameplate is normally located on the side of the drive.

Service Policy For Small Drives, DBUs, and Other Electrical Components

Should your *IMPULSE* product fail during the warranty period, Electromotive Systems will repair or replace your unit within 72 hours (3 working days). In most cases, we can supply a replacement unit within 24 hours (1 working day). If the problem is not covered under warranty, you are responsible for the cost of the repairs and the shipping charges.

To return a failed unit (or part):

1. Request a Return Authorization (RA) from Electromotive Systems' Service Department, as a condition for us to repair or replace the unit. Return the failed unit to Electromotive Systems **via pre-paid freight**. When you call, please have the serial number of the drive available.
2. A purchase order or credit card is required to cover the cost of the replacement unit or repairs to a returned unit.

Electromotive Systems will inspect the failed unit and determine if the unit is covered under warranty.

- If the unit is covered under warranty, Electromotive Systems will credit the cost of the replacement unit and/or repairs and reimburse for all reasonable freight charges.

NOTE: Freight charges incurred from sources other than common ground carriers WILL NOT be reimbursed unless pre-approved by Electromotive Systems.

- If the unit is not covered under warranty, Electromotive Systems will bill you for the cost of the replacement unit or the cost of repairs. Electromotive Systems will also bill you for a \$125.00 inspection fee (this fee will be waived if repairs are made to the unit) and any freight charges incurred by Electromotive Systems.

Magnetek Material Handling Electromotive Systems Limited Warranty

Magnetek Material Handling Electromotive Systems, hereafter referred to as Company, guarantees all items manufactured by it against any defects of material and/or workmanship for a period of two years from the date of shipment. Company makes NO OTHER WARRANTY, EXPRESSED OR IMPLIED, AS TO THE MERCHANTABILITY OR FITNESS OF THE ITEMS FOR THEIR INTENDED USE OR AS TO THEIR PERFORMANCE. Any statement, description or specification in Company's literature is for the sole purpose of identification of items sold by the Company and imparts no guarantee, warranty or undertaking by company of any kind. Components and accessories not manufactured by Magnetek Material Handling Electromotive Systems are not included in this warranty and are warranted separately by their respective manufacturers.

Company's sole liability shall be to repair at its factory, or replace any item returned to it within two years from date of shipment, which Company finds to contain defective material or workmanship. All items to be repaired or replaced shall be shipped to Company (Note: return authorization by Company is required) within said two year period, freight prepaid, as a condition to repair or replace defective material or workmanship. Company's herein assumed responsibility does not cover defects resulting from improper installation, maintenance, or improper use. Any corrective maintenance performed by anyone other than the Company during the warranty period shall void the warranty. Company shall not be liable for damages of any kind from any cause whatsoever beyond the price of the defective Company supplied items involved. Company shall not be liable for economic loss, property damage, or other consequential damages or physical injury sustained by the purchaser or by any third party as a result of the use of any Company supplied items or material.

Company neither assumes nor authorizes any other person to assume for Company any other liability in connection with the sale or use of items sold by Company.

Materials or items may not be returned for credit, without the prior written consent of the Company. Any authorized return of materials or items shall be subject to a restocking charge equal to 25% of the net invoiced amount (\$100 minimum charge for all control products) after Company determines that the material or item is in resalable condition. If upon receipt of the material or items returned, the Company determines that said material or items cannot be resold without alteration or service, the Company reserves the right to reject the returned materials or items and to send the same back to said purchaser at purchaser's expense.

Any claim for errors in shipment or for material or time shortages must be received by Company within 30 days of shipment and must be accompanied by copies of the bill of lading and packing slip.

Appendix B: IMPULSE®•P³ Series 2 External Resistor Specifications

	IMPULSE•P ³ Series 2 Drive Model No.	Traverse Resistor Part# CMAA Class A, B, C	Resistance	Traverse Resistor Part# CMAA Class D	Resistance	Hoist w/ Mechanical Load Brake CMAA Class A, B, C, D Resistor Part #	Resistance
230 Volts	2001-P3S2	EDB2001CT	220	EDB2001DTP	220	EDB2001CT	220
	2003-P3S2	EDB2001CT	220	EDB2001DTP	220	EDB2001CT	220
	2005-P3S2	EDB2003CT	110	EDB2004DTP	100	EDB2003CT	110
	2008-P3S2	EDB2006CT	58	EDB2006DTP	44	EDB2003CT	110
	2011-P3S2	EDB2009CT	37	EDB2011DTP	31	EDB2006CT	58
	2017-P3S2	EDB2015CT	25	EDB2015DTP	25	EDB2009CT	37
	2025-P3S2	EDB2022CT	14	EDB2022DT	14	EDB2015CT	25
	2033-P3S2	EDB2028CT	13	EDB2028DT	12	EDB2015CT	25
460 Volts	4001-P3S2	EDB4001CT	440	EDB4001DTP	440	EDB4001CT	440
	4002-P3S2	EDB4001CT	440	EDB4002DTP	354	EDB4001CT	440
	4003-P3S2	EDB4003CT	230	EDB4004DTP	187	EDB4001CT	440
	4004-P3S2	EDB4004CT	150	EDB4005DTP	133	EDB4003CT	230
	4008-P3S2	EDB4007CT	100	EDB4008DTP	84	EDB4004CT	150
	4014-P3S2	EDB4011CT	59	EDB4011DT	47	EDB4007CT	100
	4018-P3S2	EDB4014CT	46	EDB4014DT	37	EDB4007CT	100

If Magnetek Material Handling Electromotive Systems resistors are not used, this table should be used to determine the minimum resistance values.

Appendix C: IMPULSE•P³ Series 2 Parameter Listing

No.	Parameter Name	Initial Value	Ref Page#
n000	X-Press Programming	06	5-4
n001	Motor Rated Current	note 1	5-4
n002	Password	00	5-4
n003	Freq. Ref. 1/Lower Limit	note 2	5-6
n004	Freq. Ref. 2	note 2	5-6
n005	Freq. Ref. 3	note 2	5-6
n006	Freq. Ref. 4	note 2	5-6
n007	Freq. Ref. 5/Upper Limit	note 2	5-6
n008	Acceleration Time 1	note 2	5-7
n009	Deceleration Time 1	note 2	5-7
n010	Special Functions	0000	6-4,5,6
n011	Acceleration Time 2	2.5	5-7, 6-5
n012	Deceleration Time 2	1.5	5-7, 6-4, 5
n013	Run Signal Selection 1	note 2	6-3, 6-4
n014	Electronic Thermal Overload	0100	6-10
n015	Auto-Reset Limit	3	6-10
n016	Selection of Other Functions	0101	6-10, 5-7
n017	Overtorque Detection Selection	0000	6-10
n018	Overtorque Detection Level	100 %	6-10
n019	Overtorque Detection Time	0.2 Sec	6-10
n020	Swift Lift Frequency	60 Hz	6-6
n021	Swift Lift Enabling Current at Forward	50%	6-6
n022	Swift Lift Enabling Current at Reverse	0%	6-6
n023	Swift Lift Delay Time at Threshold Speed	0.2	6-6
n024	Analog Frequency Reference Gain	1.00	6-3
n025	Analog Frequency Reference Bias	0.00	6-3
n026	DC Injection Braking Current	50%	6-4
n027	DC Injection Time at Stop	0.5 Sec.	6-4
n028	DC Injection Decay Time	0.00 Sec.	6-4
n029	Torque Compensation Gain	1.0	6-10
n030	Stall Prevention at Accel	170 %	6-10
n031	Stall Prevention During Run	160 %	6-10
n032	Terminal S3 Select	note 2	6-8
n033	Terminal S4 Select	note 2	6-8
n034	Terminal S5 Select	note 2	6-8
n035	Relay Contact	0	6-9

No.	Parameter Name	Initial Value	Ref Page#
n036	Multi-Function Output 1 Terminal P1	4	6-9
n037	Multi-Function Output 2 Terminal P2	5	6-9
n038	Frequency Detection Level	0.0	6-10
n039	Carrier Frequency	01	6-11
n040	Analog Montior Gain	1.0	6-11
n041	Fault History		6-11
n042	Software Number		6-11
n043	Max. Output Frequency	60.0	6-7
n044	Max. Output Voltage	230/460V	6-7
n045	Max. Output Voltage Freq.	60.0	6-7
n046	Mid. Output Freq.	3.0 Hz	6-7
n047	Mid Output Voltage Freq.	note 2	6-7
n048	Min Output Frequency	1.5 Hz	6-7
n049	Min Frequency Output Voltage	note 2	6-7
n050	Analog Frequency Reference Signal Selection	0000	6-3
n051	Analog Frequency Reference Filter Time Constant	0.10	6-3
n052	Terminal S6 Select	note 2	6-8
n053	Terminal S7 Select	0F	6-8
n060	Parameter Switchover	00	6-11

Note 1: Initial value is determined by drive capacity

Note 2: Initial value is determined by n000 (X-Press Programming). See Chapter 5, tables 5-1 and 5-2, for initial values.