

## ***Heavy-Duty Aluminum Festoon Systems***

---

# **Instruction Manual**



**MAGNETEK**

MATERIAL HANDLING

**ELECTROMOTIVE SYSTEMS**

October 2008

Part Number: 125-10029-R1

© Copyright 2008 Electromotive Systems

All rights reserved. This notice applies to all copyrighted materials included with this product, including, but not limited to, this manual. This manual is intended for the sole use of the persons to whom it was provided, and any unauthorized distribution of the manual or dispersal of its contents is strictly forbidden. This manual may not be reproduced in whole or in part by any means whatsoever without the expressed written permission of MAGNETEK.

## ***DANGER, WARNING, CAUTION, and NOTE* Statements**

*DANGER, WARNING, CAUTION, and Note* statements are used throughout this manual to emphasize important and critical information. You must read these statements to help ensure safety and to prevent product damage. The statements are defined below.



### **DANGER**

*DANGER* indicates an imminently hazardous situation which, if not avoided, will result in death or serious injury. This signal word is to be limited to the most extreme situations.



### **WARNING**

*WARNING* indicates a potentially hazardous situation which, if not avoided, could result in death or serious injury.



### **CAUTION**

*CAUTION* indicates a potentially hazardous situation which, if not avoided, could result in minor or moderate injury. It may also be used to alert against unsafe practices.

*NOTE:* A *NOTE* statement is used to notify people of installation, operation, programming, or maintenance information that is important, but not hazard-related.

# Heavy-Duty Aluminum Festoon System Installation Instructions

## General Considerations

1. Determine the length of the span to be festooned with consideration given to the storage distance (stack up) impact upon the actual travel distance of the moving equipment and the speed at which the system will run.
  - a. To determine storage/stack up area, multiply length of trolley by number of trolleys to acquire storage length (i.e. 5" long trolley x 10 trolleys = 50")
  - b. To determine the length of track required, add the sum of the storage distance, the working travel, and  $\frac{1}{2}$  the length of the lead trolley. Consider that Heavy Duty Aluminum Track is available in either 10 or 20 foot standard sections or can be supplied in cut-lengths of whole foot increments.
  - c. Heavy Duty Aluminum sections may also be curved to a special radius and degree of arc (minimum radius 36")—please consult factory.
  - d. For systems with speeds of 250 feet per minute or more, consult the factory, as tow cables/chains may be required.
2. Determine the desired loop depth. A 3-foot loop depth is common. A deeper loop depth requires fewer trolleys and reduces the storage (stack up) distance.
3. Select proper Flat Cable that meets or exceeds the electrical requirements of the application based upon the amperage and conductors required. The total number of control wires should include one common and one ground. Additional wires may be required for brakes, limit switches, or other devices when controls are mounted remotely from their motors.
  - a. The length of cable required is the sum of the length of track, plus approximately 20% for cable sag, plus the distance to power source.
  - b. Calculate total weight of cable per trolley to ensure that a maximum of 150 lbs. per trolley is not exceeded—see cable data sheet. Cables may be stacked in the saddle so long as the maximum weight per trolley is not exceeded.
4. Determine the track support/hanger spacing. Recommended hanger spacing is 10 ft. centers.
  - a. It may be necessary to add another support/hanger in the storage/stack up area caused by additional weight when trolleys accumulate in storage area and heavier gauge cables are used.
  - b. Consult factory for proper support spacing on curved systems. Most curved systems are supported every  $2\frac{1}{2}$  feet on each curve and every 10 feet on straight sections.
5. Determine the number of trolleys required by dividing the length of the run by the total amount of cable required for one loop. (i.e. A 3 foot loop depth requires 6 feet of cable). The number of intermediate trolleys will be reduced by (1) to account for a lead/tow trolley or control box trolley. Trolleys for anti-lift rollers are recommended for curved systems.
6. Determine the junction box size and terminal strips required for the amount of conductors being festooned from the power source and/or the control box trolley. Cable grips are available for terminating cable in various sizes and multiple cable accommodations.

# Heavy-Duty Aluminum Standard Configuration

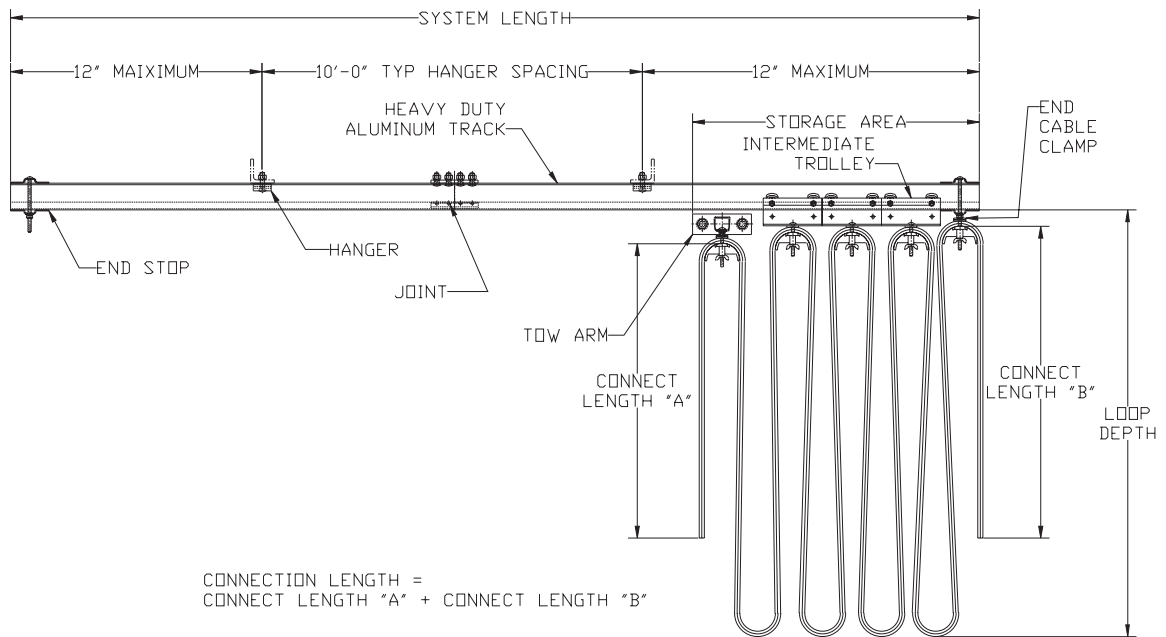

Figure 1

## Standard System Components

Part No.	Description	Page Number	*Tech. Bulletin #
F-HT10	Heavy Duty Aluminum Track Section – 10 foot	6	FS-HT1
F-HT20	Heavy Duty Aluminum Track Section – 20 foot	6	FS-HT1
F-HT "X"	Cross Arm Brackets – "X" = 1 foot increments	6	FS-HT1
FS-HTJ	Joint Assembly - 2 piece	6	FS-HT1
F-HTA	Tow Arm/Cable Saddle Assembly	7	FS-HT5
F-HTH	Heavy Duty Aluminum Hanger Assembly-2 piece	7	FS-HT2
F-HTE	Heavy Duty End Cable Clamp	8	FS-HT2
F-HTS	Heavy Duty End Stop Assembly	9	FS-HT6
F-HCB	Heavy Duty Control Box Trolley	9	FS-HT6
F-HC3	Heavy Duty Intermediate Trolley – 3" frame	10	FS-HT8
F-HC5	Heavy Duty Intermediate Trolley – 5" frame	10	FS-HT8

*Additional Components:*

*Pendant pushbutton stations and round pendant cable available in standard and custom configurations—consult factory*

*Trolleys and Anti-Lift Rollers also available—recommended for curved systems*

*Corrosion Resistant and Part Resistant Trolleys also available*

*Components for multiple saddle and/or round cable also available—consult factory*

\* For your reference technical bulletins for most components maybe requested by calling the factory or are available on-line at [www.magnetekmh.com](http://www.magnetekmh.com) under "Document Center" in the Festoon Section of the "Applications Bulletins" page.

## Installation Procedures (refer to drawing–figure 1)

1. Install angle, channels, etc., support brackets (supplied by others)–welded or bolted to beam, sufficient to carry 250 lbs. each.
2. Install Track Hangers on support brackets with fasteners furnished. Leave the mounting bolts loose so Aluminum Heavy Duty Track can be inserted.
3. Install Aluminum Heavy Duty Track into Hanger Clamps. Tighten the Hanger Clamps slightly to allow the track to move when installing Track Joints. Once the Track Joints are securely in place, tighten the Hanger Clamps firmly.
4. Join Aluminum Heavy Duty Track sections together by installing the two piece Track Joint onto the track. Slide the half-moon shaped track joint piece into the bottom area of the track. Butt both sections of track together and slide the bottom Track Joint into the joining track, centering the Track Joint. Tighten the set screws firmly to lock track into place. Next, mount the top joint plate and tighten the hardware (carriage bolts should be pointing up) securely in place.
5. Insert the Lead/Tow Trolley or Control Box Trolley and intermediate Cable Trolleys onto the Aluminum Track – make sure all trolleys roll freely.
6. Install the End Cable Clamp assembly onto the Aluminum Track at the cable storage end. Tighten securely.
7. Install the End Stop on the Aluminum Track end, opposite the storage end.
8. Loosen (but do not remove) the wing nuts on the trolley saddles. Feed the festoon cables into the trolleys between the clamping pad and saddle. Make sure to leave enough cable past the Tow/Lead Trolley or Control Box Trolley to wire into enclosure. Measure the desired loop depth and tighten the wing nuts to secure the festoon cables.
9. Install festoon cable grips into approved junction boxes and insert cables through the cable glands. Tighten cable grip nuts firmly to secure cables.
10. For power & control applications, install the Tow Arm in the center of the rectangular box mounted on the Tow/Lead Trolley. The Tow Arm should be securely fastened to the moving equipment to be electrified.
11. For traveling pendant pushbutton applications, install the junction box on the Control Box Trolley. Fasten securely with hardware furnished.
12. Run the entire festoon system back and forth several times over the entire system to ensure proper operation. Flat festoon cables should extend and retract in a straight line if the cables have been properly fastened to the trolleys.

# Flat Festoon Cables and Trolleys–Engineering Data

## Trolley Specifications

- 150 lb. capacity each Trolley
- Trolleys equipped with ball bearing wheels capable of traveling up to 250 feet per minute
- Trolleys can be supplied with anti-lift rollers
- Corrosion resistant Trolley includes epoxy coated steel parts and steel wheels
- Spark Resistant Trolley includes stainless steel parts and brass wheels
- Consult factory for systems with speeds of 250 feet per minute or higher

## Cable Saddle Specifications

- 3” and 5” Trolleys have a 3” diameter nylon cable saddle with 1” X 2¼” maximum cable opening
- 3” and 5” Trolley frames available with multiple saddle configurations for flat or round cable–consult factory

## Flat Festoon Cable Reference–Standard Cable Specifications

- Indoor/Outdoor Festoon flat cable and round pendant control cable
- 105°C (221°F) 600 volt AC, 250 volt DC
- Conductors are annealed copper
- Each conductor has color coded jacket
- Jacket rating -40°C (-40°F) to 105°C (221°F)
- Resistant to UV, ozone, water, oil and weather
- 4, 8, or 12 conductor flat cable
- #2 AWG through #16 AWG flat cable

Part No.	AWG Size	# of Cond.	Dimensions (Inches)	Ampacity*	Approximate lbs/MFT	Bend Radius (in.)
F-16/8	16	8	0.200 X 1.110	14	194	0.80
F-16/12	16	12	0.200 X 1.605	14	292	0.80
F-14/4	14	4	0.210 X 0.625	27	138	0.84
F-14/8	14	8	0.210 X 1.175	19	254	0.84
F-14/12	14	12	0.210 X 1.700	19	380	0.84
F-12/4	12	4	0.230 X 0.710	33	180	0.92
F-12/8	12	8	0.230 X 1.340	23	343	0.92
F-10/4	10	4	0.270 X 0.880	44	239	1.08
F-8/4	8	4	0.365 X 1.190	60	401	1.46
F-6/4	6	4	0.430 X 1.450	82	620	1.72
F-4/4	4	4	0.490 X 1.690	104	896	1.96
F-2/4	2	4	0.560 X 1.955	142	1278	2.24

\*Ampacities are de-rated at higher temperatures (above 30°C).

Minimum Bending Radius (approx. 4 X cable thickness)

Specialty cable also available–contact the factory for more information

Cable available in specific lengths or in Full Reels of 500 or 1000 feet

■ –Not suitable for 3” diameter saddle

## Heavy Duty Aluminum Track

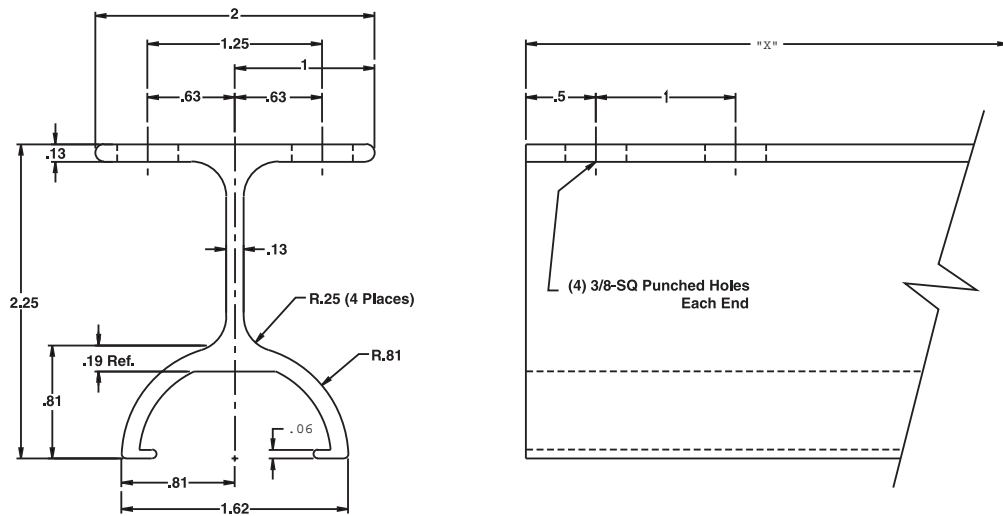

**Figure 1**

- F-HT10 Heavy Duty Aluminum Track x 10'-0" (+/- 0.125")
- F-HT20 Heavy Duty Aluminum Track x 20'-0" (+/- 0.125")
- F-HTX Heavy Duty Aluminum Track x "X" Length  
1.0 lbs/ft.

## Heavy Duty Aluminum Joint Assembly

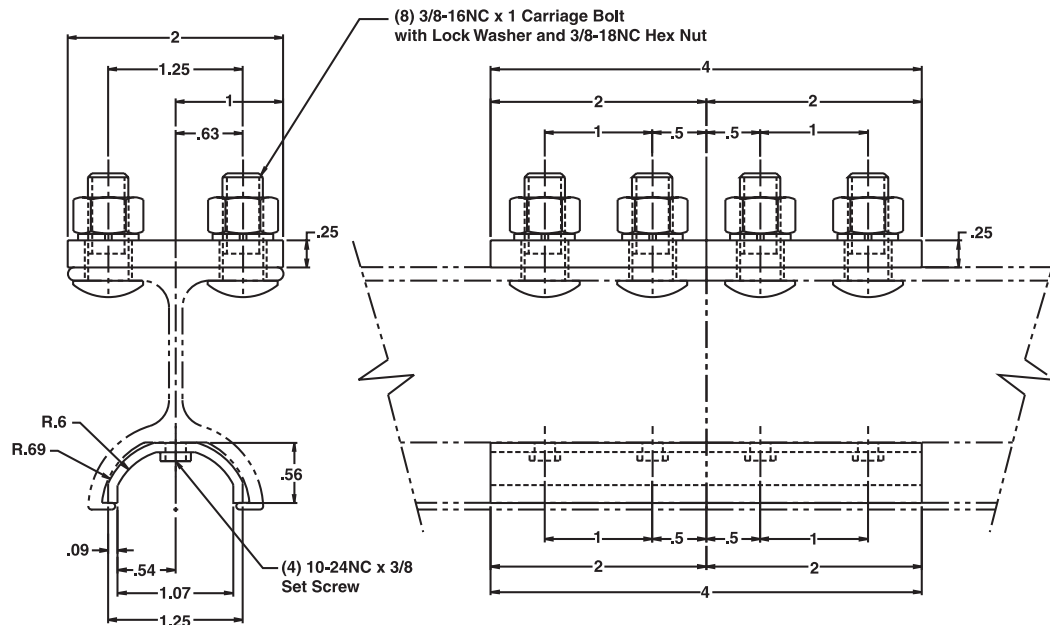

**Figure 2**

- F-HTJ Heavy Duty Aluminum Joint Assembly (2 Piece Assembly)–1.0 lbs./ft.

## Heavy Duty Tow Arm/Cable Saddle Assembly

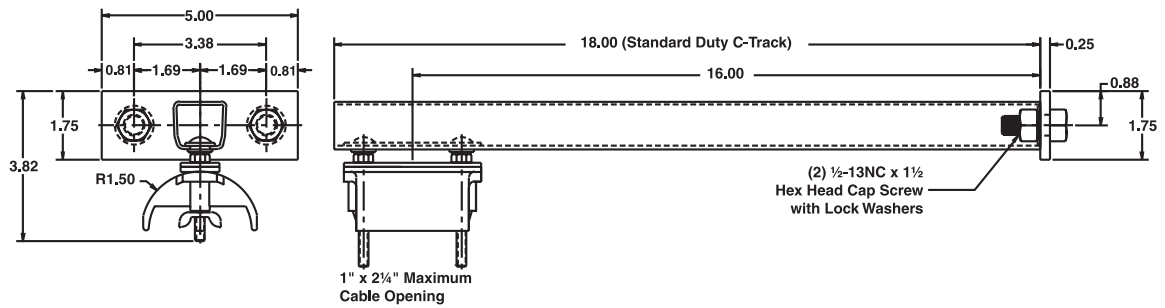

**Figure 3**

- F-HTA Heavy Duty Tow Arm/Cable Saddle Assembly  
 F-HTA-SS Heavy Duty Stainless Steel Tow Arm/Cable Saddle Assembly  
 3.25 lbs/ea.

## Heavy Duty Aluminum Track Hanger Assembly

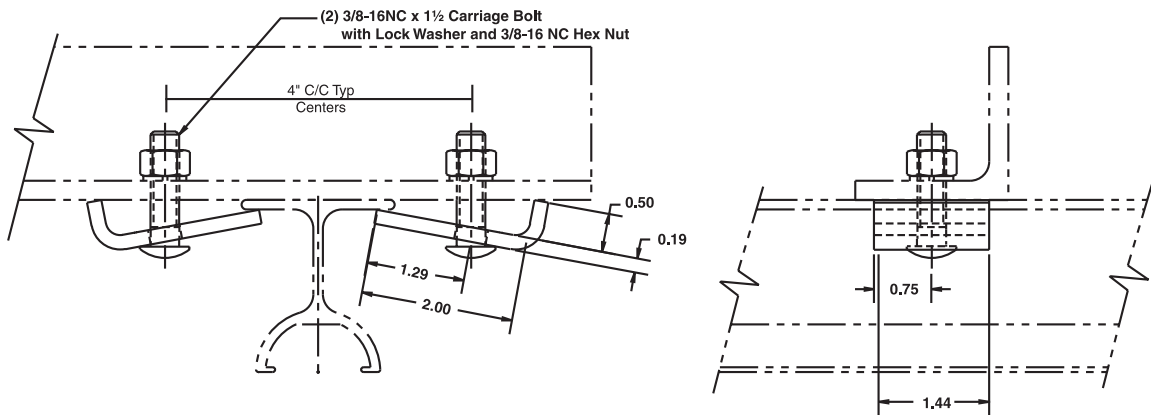
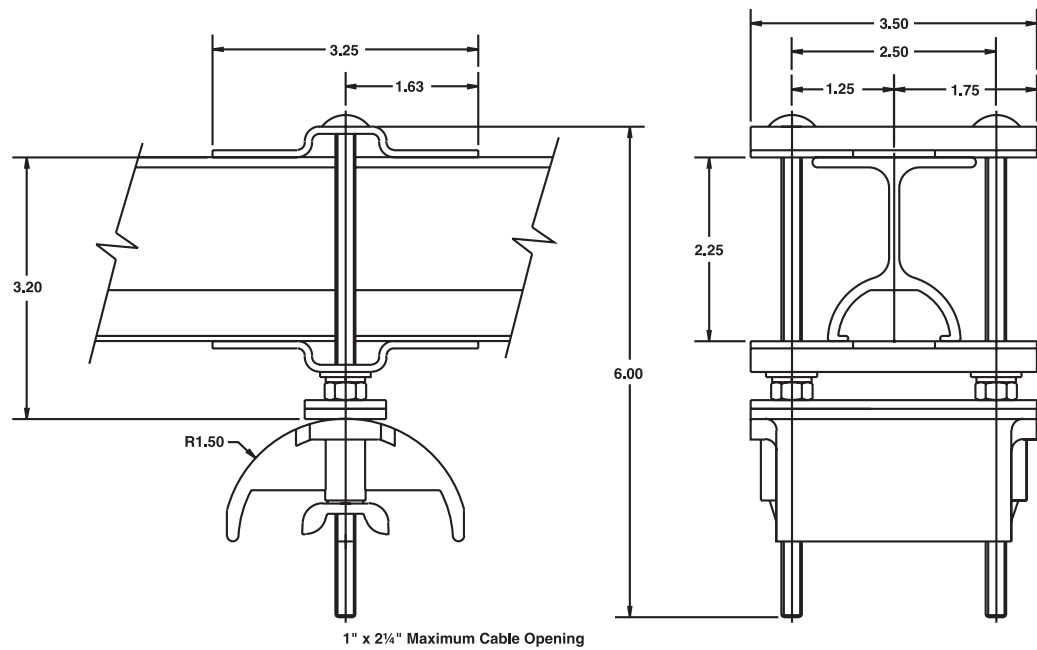

**Figure 4**

- F-HTH Heavy Duty Aluminum Track Hanger Assembly (2 Piece Assembly)  
 0.80 lbs./assembly



## Heavy Duty End Cable Clamp



*Figure 5*

F-HTE Heavy Duty End Cable Clamp  
F-HTE-SS Heavy Duty Stainless Steel End Cable Clamp  
0.90 lbs./ea.

## Heavy Duty End Stop Assembly

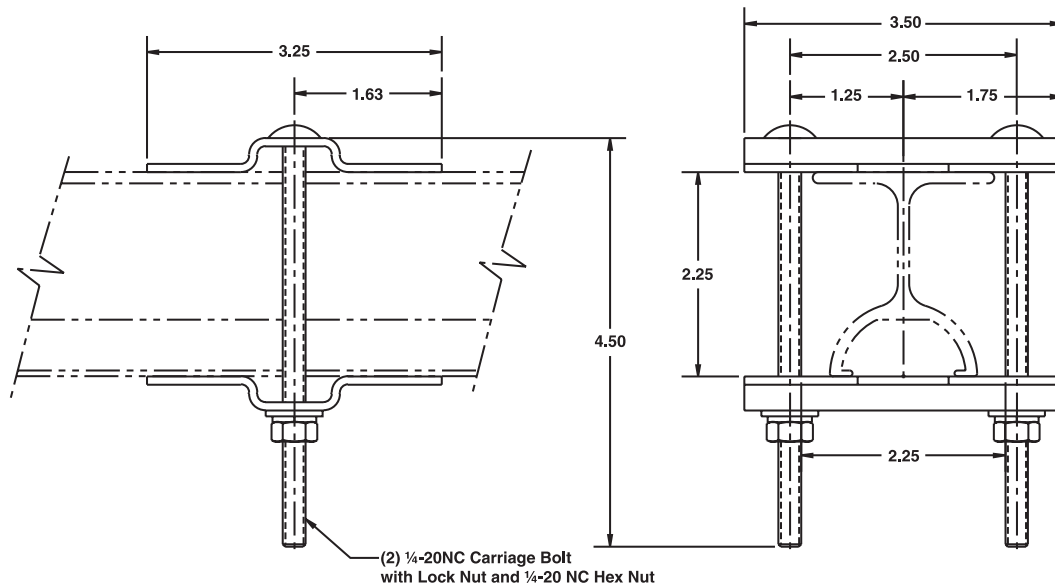

**Figure 6**

- F-HTS Heavy Duty End Stop Assembly
- F-HTS-SS Heavy Duty Stainless Steel End Stop Assembly
- 0.60 lbs./assembly

## Heavy Duty Control Box Trolley

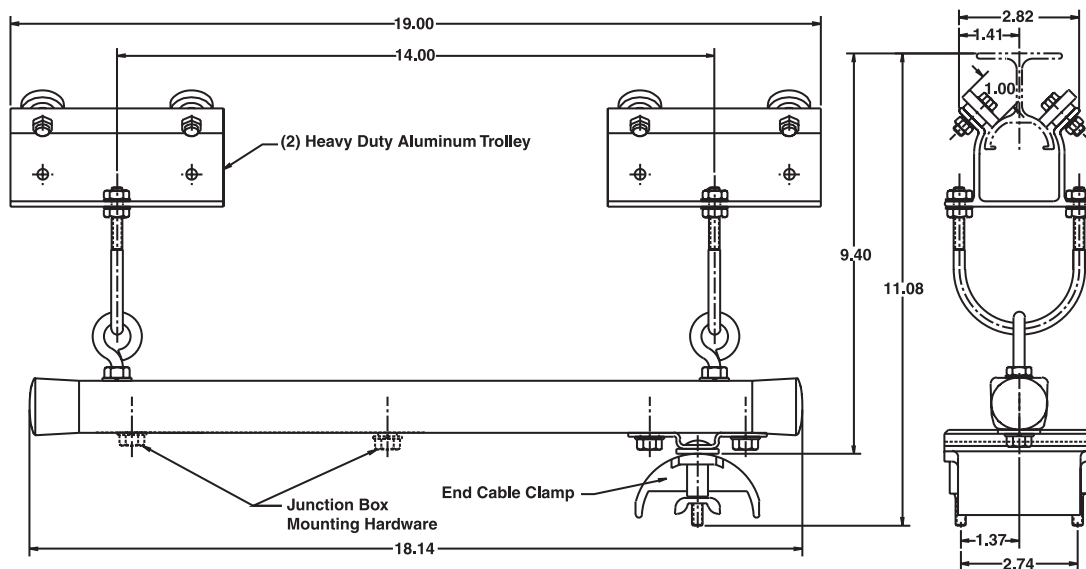

**Figure 7**

- F-HCB Heavy Duty Control Box Trolley
- F-HCBX1 Heavy Duty Corrosion Resistant Control Box Trolley (Stainless Steel Wheels and Hardware)
- 5.20 lb./ea.

# Heavy Duty Aluminum Trolley

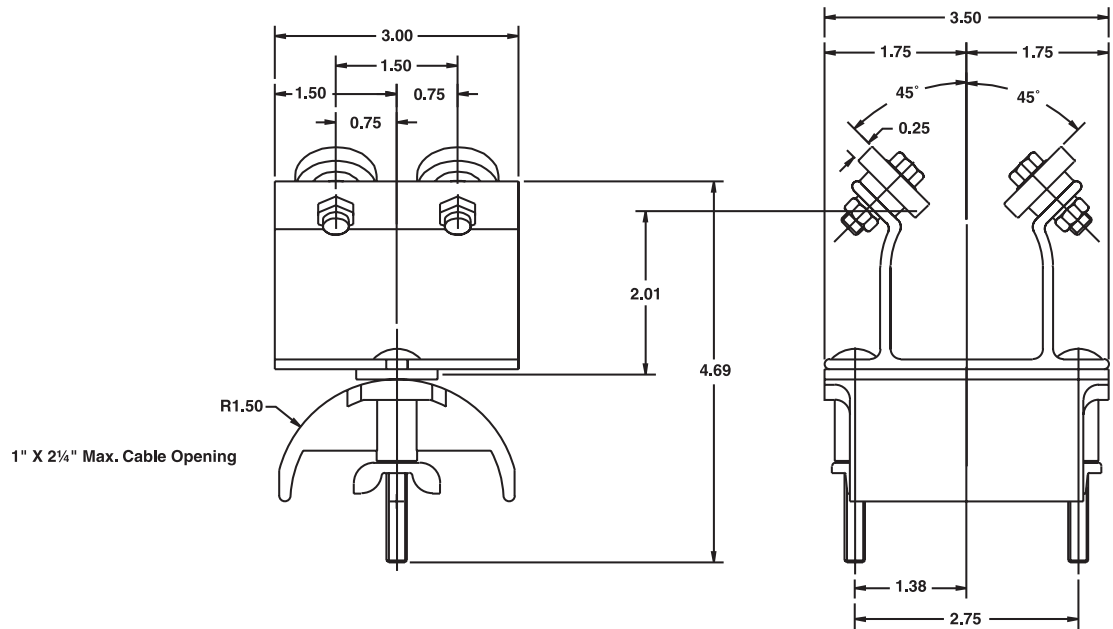

**Figure 8**

F-HC3 Heavy Duty Aluminum Trolley–0.85 lbs./ea.

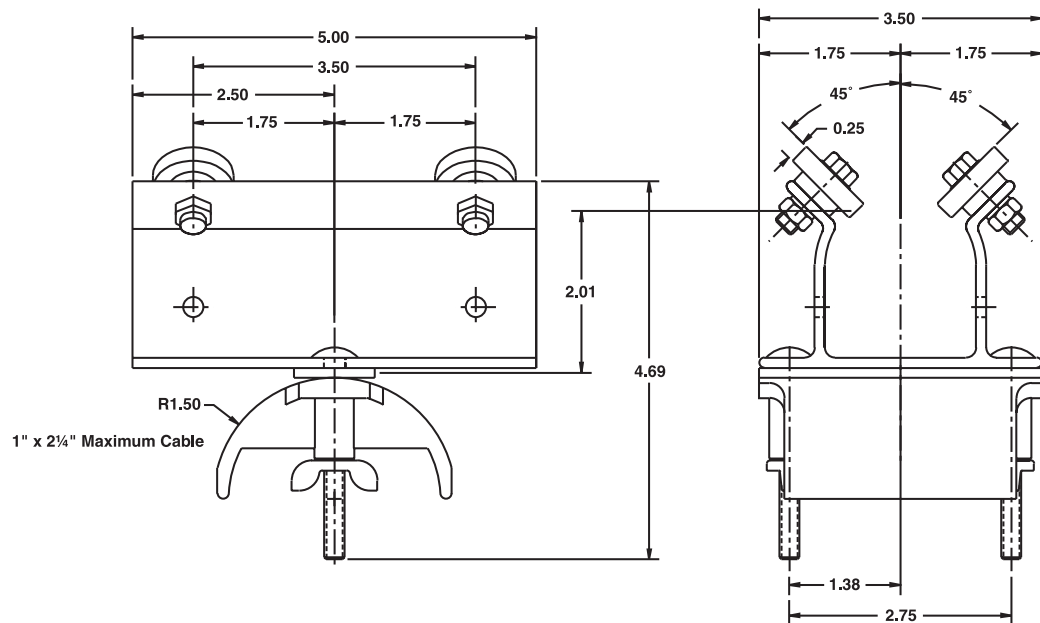

**Figure 9**

F-HC5 Heavy Duty Aluminum Trolley  
 F-HC5X1 Heavy Duty Aluminum Corrosion Resistant Trolley (Stainless Steel Wheels and Hardware)  
 1.25 lbs./ea.